

Σ -7-Series AC Servo Drive **Σ -7S SERVOPACK with FT/EX Specification for Indexing Application Product Manual**

Model: SGD7S-□□□□00□□□□F79□

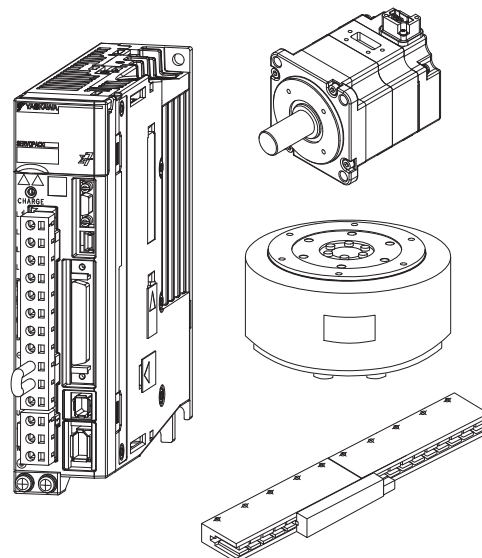

Basic Information on SERVOPACKS	1
SERVOPACK Ratings and Specifications	2
Wiring and Connecting SERVOPACKS	3
Trial Operation	4
Monitoring	5
Settings	6
Operation with Digital I/O	7
Maintenance	8
Parameter Lists	9
Appendices	10

Copyright © 2015 YASKAWA ELECTRIC CORPORATION

All rights reserved. No part of this publication may be reproduced, stored in a retrieval system, or transmitted, in any form, or by any means, mechanical, electronic, photocopying, recording, or otherwise, without the prior written permission of Yaskawa. No patent liability is assumed with respect to the use of the information contained herein. Moreover, because Yaskawa is constantly striving to improve its high-quality products, the information contained in this manual is subject to change without notice. Every precaution has been taken in the preparation of this manual. Nevertheless, Yaskawa assumes no responsibility for errors or omissions. Neither is any liability assumed for damages resulting from the use of the information contained in this publication.

About this Manual

This manual describes the Σ -7-Series AC Servo Drive Σ -7S SERVOPACKs for indexing applications.

Read and understand this manual to ensure correct usage of the Σ -7-Series AC Servo Drives. Keep this manual in a safe place so that it can be referred to whenever necessary.

Outline of Manual

The contents of the chapters of this manual are described in the following table.

When you use the Σ -7S SERVOPACKs for indexing applications, use this manual together with the relevant Σ -7-Series product manual.

	Item	This Manual	Σ -7S SERVOPACKs Analog Voltage/Pulse Train References Product Manual
Basic Information on SERVOPACKs	The Σ -7 Series	-	1.1
	Product Introduction	1.1	-
	Interpreting the Nameplate	-	1.2
	Part Names	-	1.3
	Model Designations	1.2	-
	Combinations of SERVOPACKs and Servomotors	1.3	-
	Functions	-	1.6
Selecting a SERVOPACK	Ratings	2.1	-
	SERVOPACK Overload Characteristics	2.2	-
	Specifications	2.3	-
	Block Diagrams	-	2.2
	External Dimensions	-	2.3
	Examples of Standard Connections between SERVOPACKs and Peripheral Devices	-	2.4
SERVOPACK Installation		-	Chapter 3
Wiring and Connecting SERVOPACKs	Wiring and Connecting SERVOPACKs	-	4.1
	Basic Wiring Diagrams	3.1	-
	Wiring the Power Supply to the SERVOPACK	-	4.3
	Wiring Servomotors	-	4.4
	I/O Signal Connections	3.2	-
	Connecting Safety Function Signals	-	4.6
	Connecting the Other Connectors	-	4.7
Basic Functions That Require Setting before Operation		-	Chapter 5
Application Functions		-	Chapter 6

Continued on next page.

Continued from previous page.

Item		This Manual	Σ-7S SERVOPACKs Analog Voltage/Pulse Train References Product Manual
Trial Operation and Actual Operation	Flow of Trial Operation	-	7.1
	Inspections and Confirmations before Trial Operation	-	7.2
	Trial Operation for the Servomotor without a Load	-	7.3
	Trial Operation Example	4.1	-
	Trial Operation from the Host Controller for the Servomotor without a Load	-	7.4
	Trial Operation with the Servomotor Connected to the Machine	-	7.5
	Convenient Function to Use during Trial Operation	-	7.6
Tuning		-	Chapter 8
Monitoring	Monitoring Product Information	-	9.1
	Monitoring SERVOPACK Status	5.1	-
	Monitoring Machine Operation Status and Signal Waveforms	5.2	-
	Monitoring Product Life	-	9.4
	Alarm Tracing	-	9.5
Fully-Closed Loop Control		-	Chapter 10
Safety Functions		-	Chapter 11
Settings	Control Method Selection	6.1	-
	I/O Signal Allocations	6.2	-
	Moving Mode and Coordinate Settings	6.3	-
	Settings for References	6.4	-
	Origin Settings	6.5	-
Operation with Digital I/O	Operations	7.1	-
	Homing	7.2	-
	Program Table Operation	7.3	-
	Jog Speed Table Operation	7.4	-
	ZONE Outputs	7.5	-
Maintenance	Inspections and Part Replacement	-	12.1
	Alarm Displays		-
	List of Alarms	8.1.1	-
	Troubleshooting Alarms	8.1.2	-
	INDEXER Warning Displays and Troubleshooting	8.1.3	-
	Resetting Alarms	-	12.2.3
	Alarm History Display	-	12.2.4
	Clearing the Alarm History	-	12.2.5
	Resetting Alarms Detected in Option Modules	-	12.2.6
	Resetting Motor Type Alarms	-	12.2.7
	Warning Displays	8.2	-
Troubleshooting Based on the Operation and Conditions of the Servomotor	8.3	-	
Panel Displays and Panel Operator Procedures		-	Chapter 13
Parameter Lists	Parameter Configuration	9.1	-
	List of Parameters	9.2	-
	Parameter Recording Table	-	14.2

Continued on next page.

Continued from previous page.

Item		This Manual	Σ -7S SERVOPACKs Analog Voltage/Pulse Train References Product Manual
Appendices	Examples of Connections to Host Controllers	-	15.1
	Corresponding SERVOPACK and SigmaWin+ Function Names	10.1	-
	Operation of Digital Operator	10.2	-

Related Documents

The relationships between the documents that are related to the Servo Drives are shown in the following figure. The numbers in the figure correspond to the numbers in the table on the following pages. Refer to these documents as required.

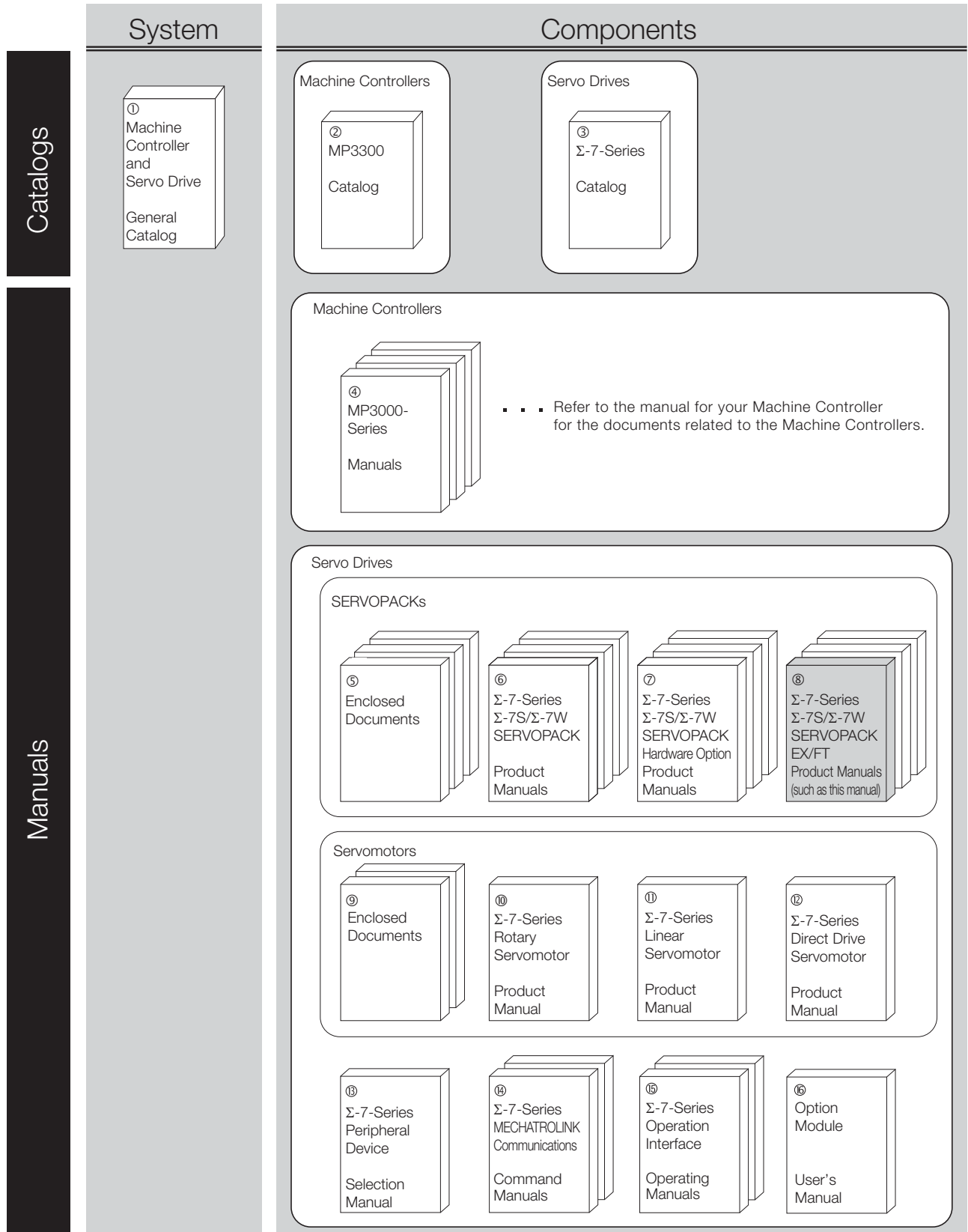

Classification	Document Name	Document No.	Description
① Machine Controller and Servo Drive General Catalog	Machine Controller and AC Servo Drive Solutions Catalog	KAEP S800001 22	Describes the features and application examples for combinations of MP3000-Series Machine Controllers and Σ -7-Series AC Servo Drives.
② MP3300 Catalog	Machine Controller MP3300	KAEP C880725 03	Provides detailed information on MP3300 Machine Controllers, including features and specifications.
③ Σ -7-Series Catalog	AC Servo Drives Σ -7 Series	KAEP S800001 23	Provides detailed information on Σ -7-Series AC Servo Drives, including features and specifications.
④ MP3000-Series Manual	Machine Controller MP3000 Series MP3300 Product Manual	SIEP C880725 21	Describes the functions, specifications, operating methods, maintenance, inspections, and troubleshooting of the MP3000-series MP3300 Machine Controllers.
⑤ Enclosed Documents	Σ -7-Series AC Servo Drive Σ -7S and Σ -7W SERVOPACK Safety Precautions	TOMP C710828 00	Provides detailed information for the safe usage of Σ -7-Series SERVOPACKs.
	Σ -V-Series/ Σ -V-Series for Large-Capacity Models/ Σ -7-Series Safety Precautions Option Module	TOBP C720829 00	Provides detailed information for the safe usage of Option Modules.
	Σ -V-Series/ Σ -V-Series for Large-Capacity Models/ Σ -7-Series Installation Guide Command Option Module	TOBP C720829 01	Provides detailed procedures for installing a Command Option Module in a SERVOPACK.
	Σ -V-Series/ Σ -V-Series for Large-Capacity Models/ Σ -7-Series Installation Guide Fully-closed Module	TOBP C720829 03	Provides detailed procedures for installing the Fully-closed Module in a SERVOPACK.
	Σ -V-Series/ Σ -V-Series for Large-Capacity Models/ Σ -7-Series Installation Guide Safety Module	TOBP C720829 06	Provides detailed procedures for installing the Safety Module in a SERVOPACK.
	Σ -V-Series/ Σ -V-Series for Large-Capacity Models/ Σ -7-Series Installation Guide INDEXER Module	TOBP C720829 02	Provides detailed procedures for installing the INDEXER Module in a SERVOPACK.
	Σ -V-Series/ Σ -V-Series for Large-Capacity Models/ Σ -7-Series Installation Guide DeviceNet Module	TOBP C720829 07	Provides detailed procedures for installing the DeviceNet Module in a SERVOPACK.

Continued on next page.

Continued from previous page.

Classification	Document Name	Document No.	Description
⑥ Σ-7-Series Σ-7S/Σ-7W SERVOPACK Product Manuals	Σ-7-Series AC Servo Drive Σ-7S SERVOPACK with MECHATROLINK-III Communications References Product Manual	SIEP S800001 28	Provide detailed information on selecting Σ-7-Series SERVO-PACKs and information on installing, connecting, setting, performing trial operation for, tuning, and monitoring the Servo Drives.
	Σ-7-Series AC Servo Drive Σ-7S SERVOPACK with MECHATROLINK-II Communications References Product Manual	SIEP S800001 27	
	Σ-7-Series AC Servo Drive Σ-7S SERVOPACK with Analog Voltage/Pulse Train References Product Manual	SIEP S800001 26	
	Σ-7-Series AC Servo Drive Σ-7S SERVOPACK Command Option Attachable Type with INDEXER Module Product Manual	SIEP S800001 64	
	Σ-7-Series AC Servo Drive Σ-7S SERVOPACK Command Option Attachable Type with DeviceNet Module Product Manual	SIEP S800001 70	
	Σ-7-Series AC Servo Drive Σ-7W SERVOPACK with MECHATROLINK-III Communications References Product Manual	SIEP S800001 29	
⑦ Σ-7-Series Σ-7S/Σ-7W SERVOPACK with Hardware Option Specifications Product Manuals	Σ-7-Series AC Servo Drive Σ-7S/Σ-7W SERVOPACK with Hardware Option Specifications Dynamic Brake Product Manual	SIEP S800001 73	Provide detailed information on Hardware Options for Σ-7-Series SERVOPACKs.
	Σ-7-Series AC Servo Drive Σ-7W SERVOPACK with Hardware Option Specifications HWBB Function Product Manual	SIEP S800001 72	
⑧ Σ-7-Series Σ-7S/Σ-7W SERVOPACK with EX/FT Specification Product Manuals	Σ-7-Series AC Servo Drive Σ-7S SERVOPACK with FT/EX Specification for Indexing Application Product Manual	This manual (SIEP S800001 84)	Provide detailed information on the EX/FT specification for Σ-7-Series SERVOPACKs.
	Σ-7-Series AC Servo Drive Σ-7S SERVOPACK with FT/EX Specification for Tracking Application Product Manual	SIEP S800001 89	
	Σ-7-Series AC Servo Drive Σ-7S SERVOPACK with FT/EX Specification for SGM7D Motor Product Manual	SIEP S800001 91	

Continued on next page.

Continued from previous page.

Classification	Document Name	Document No.	Description
⑨ Enclosed Documents	AC Servo Drive Rotary Servomotor Safety Precautions	TOBP C230260 00	Provides detailed information for the safe usage of Rotary Servomotors and Direct Drive Servomotors.
	AC Servomotor Linear Σ Series Safety Precautions	TOBP C230800 00	Provides detailed information for the safe usage of Linear Servomotors.
⑩ Σ -7-Series Rotary Servomotor Product Manual	Σ -7-Series AC Servo Drive Rotary Servomotor Product Manual	SIEP S800001 36	Provide detailed information on selecting, installing, and connecting the Σ -7-Series Servomotors.
⑪ Σ -7-Series Linear Servomotor Product Manual	Σ -7-Series AC Servo Drive Linear Servomotor Product Manual	SIEP S800001 37	
⑫ Σ -7-Series Direct Drive Servomotor Product Manual	Σ -7-Series AC Servo Drive Direct Drive Servomotor Product Manual	SIEP S800001 38	
⑬ Σ -7-Series Peripheral Device Selection Manual	Σ -7-Series AC Servo Drive Peripheral Device Selection Manual	SIEP S800001 32	Describes the peripheral devices for a Σ -7-Series Servo System.
⑭ Σ -7-Series MECHATROLINK Communications Command Manuals	Σ -7-Series AC Servo Drive MECHATROLINK-II Communications Command Manual	SIEP S800001 30	Provides detailed information on the MECHATROLINK-II communications commands that are used for a Σ -7-Series Servo System.
	Σ -7-Series AC Servo Drive MECHATROLINK-III Communications Standard Servo Profile Command Manual	SIEP S800001 31	Provides detailed information on the MECHATROLINK-III communications standard servo profile commands that are used for a Σ -7-Series Servo System.
⑮ Σ -7-Series Operation Interface Operating Manuals	Σ -7-Series AC Servo Drive Digital Operator Operating Manual	SIEP S800001 33	Describes the operating procedures for a Digital Operator for a Σ -7-Series Servo System.
	AC Servo Drives Engineering Tool SigmaWin+ Operation Manual	SIET S800001 34	Provides detailed operating procedures for the SigmaWin+ Engineering Tool for a Σ -7-Series Servo System.
⑯ Option Module User's Manual	Σ -V-Series/ Σ -V-Series for Large-Capacity Models/ Σ -7-Series User's Manual Safety Module	SIEP C720829 06	Provides details information required for the design and maintenance of a Safety Module.

Using This Manual

◆ Technical Terms Used in This Manual

The following terms are used in this manual.

Term	Meaning
Servomotor	A Σ -7-Series Rotary Servomotor, Direct Drive Servomotor, or Linear Servomotor.
Rotary Servomotor	A generic term used for a Σ -7-Series Rotary Servomotor (SGM7J, SGM7A, SGM7P, or SGM7G) or a Direct Drive Servomotor (SGMCS or SGMCV). The descriptions will specify when Direct Drive Servomotors are excluded.
Linear Servomotor	A Σ -7-Series Linear Servomotor (SGLG, SGLF, SGLT, or SGLC).
SERVOPACK	A Σ -7-Series Σ -7S Servo Amplifier with Analog Voltage/Pulse Train References.
Servo Drive	The combination of a Servomotor and SERVOPACK.
Servo System	A servo control system that includes the combination of a Servo Drive with a host controller and peripheral devices.
servo ON	Supplying power to the motor.
servo OFF	Not supplying power to the motor.
base block (BB)	Shutting OFF the power supply to the motor by shutting OFF the base current to the power transistor in the SERVOPACK.
servo lock	A state in which the motor is stopped and is in a position loop with a position reference of 0.
Main Circuit Cable	One of the cables that connect to the main circuit terminals, including the Main Circuit Power Supply Cable, Control Power Supply Cable, and Servomotor Main Circuit Cable.
SigmaWin+	The Engineering Tool for setting up and tuning Servo Drives or a computer in which the Engineering Tool is installed.

◆ Differences in Terms for Rotary Servomotors and Linear Servomotors

There are differences in the terms that are used for Rotary Servomotors and Linear Servomotors. This manual primarily describes Rotary Servomotors. If you are using a Linear Servomotor, you need to interpret the terms as given in the following table.

Rotary Servomotors	Linear Servomotors
torque	force
moment of inertia	mass
rotation	movement
forward rotation and reverse rotation	forward movement and reverse movement
CW and CCW pulse trains	forward and reverse pulse trains
rotary encoder	linear encoder
absolute rotary encoder	absolute linear encoder
incremental rotary encoder	incremental linear encoder
unit: min^{-1}	unit: mm/s
unit: N·m	unit: N

◆ Notation Used in this Manual

■ Notation for Reverse Signals

The names of reverse signals (i.e., ones that are valid when low) are written with a forward slash (/) before the signal abbreviation.

Notation Example

\overline{BK} is written as /BK.

■ Notation for Parameters

The notation depends on whether the parameter requires a numeric setting (parameter for numeric setting) or requires the selection of a function (parameter for selecting functions).

• Parameters for Numeric Settings

Pn100	Speed Loop Gain				
	Setting Range	Setting Unit	Default Setting	When Enabled	Classification
	10 to 20,000	0.1 Hz	400	Immediately	Tuning

Parameter number

This is the setting range for the parameter.

This is the minimum unit (setting increment) that you can set for the parameter.

This is the parameter setting before shipment.

This is when any change made to the parameter will become effective.

This is the parameter classification.

• Parameters for Selecting Functions

Parameter	Meaning	When Enabled	Classification
Pn002	n.□0□□ (default setting)	After startup	Setup
	n.□1□□		
	n.□2□□		

Parameter number

The notation "n.□□□□" indicates a parameter for selecting functions. Each □ indicates the setting for one digit. The notation shown here means that the third digit from the right is set to 2.

This column explains the selections for the function.

Notation Example

Notation Examples for Pn002

n . 0 0 0 0	Digit Notation		Numeric Value Notation	
	Notation	Meaning	Notation	Meaning
→	Pn002 = n.□□□X	Indicates the first digit from the right in Pn002.	Pn002 = n.□□□1	Indicates that the first digit from the right in Pn002 is set to 1.
→	Pn002 = n.□□X□	Indicates the second digit from the right in Pn002.	Pn002 = n.□□1□	Indicates that the second digit from the right in Pn002 is set to 1.
→	Pn002 = n.□X□□	Indicates the third digit from the right in Pn002.	Pn002 = n.□1□□	Indicates that the third digit from the right in Pn002 is set to 1.
→	Pn002 = n.X□□□	Indicates the fourth digit from the right in Pn002.	Pn002 = n.1□□□	Indicates that the fourth digit from the right in Pn002 is set to 1.

◆ Engineering Tools Used in This Manual

This manual uses the interfaces of the SigmaWin+ for descriptions.

◆ Trademarks

- QR code is a trademark of Denso Wave Inc.
- Other product names and company names are the trademarks or registered trademarks of the respective company. “TM” and the ® mark do not appear with product or company names in this manual.

◆ Visual Aids

The following aids are used to indicate certain types of information for easier reference.

 Important	Indicates precautions or restrictions that must be observed. Also indicates alarm displays and other precautions that will not result in machine damage.
--	---

 Term	Indicates definitions of difficult terms or terms that have not been previously explained in this manual.
---	---

Example Indicates operating or setting examples.

Information Indicates supplemental information to deepen understanding or useful information.

Safety Precautions

◆ Safety Information

To prevent personal injury and equipment damage in advance, the following signal words are used to indicate safety precautions in this document. The signal words are used to classify the hazards and the degree of damage or injury that may occur if a product is used incorrectly. Information marked as shown below is important for safety. Always read this information and heed the precautions that are provided.



DANGER

- Indicates precautions that, if not heeded, are likely to result in loss of life, serious injury, or fire.



WARNING

- Indicates precautions that, if not heeded, could result in loss of life, serious injury, or fire.



CAUTION

- Indicates precautions that, if not heeded, could result in relatively serious or minor injury, or in fire.

NOTICE

- Indicates precautions that, if not heeded, could result in property damage.

◆ Safety Precautions That Must Always Be Observed

■ General Precautions



DANGER

- Read and understand this manual to ensure the safe usage of the product.
- Keep this manual in a safe, convenient place so that it can be referred to whenever necessary. Make sure that it is delivered to the final user of the product.
- Do not remove covers, cables, connectors, or optional devices while power is being supplied to the SERVOPACK.
There is a risk of electric shock, operational failure of the product, or burning.



WARNING

- Use a power supply with specifications (number of phases, voltage, frequency, and AC/DC type) that are appropriate for the product.
There is a risk of burning, electric shock, or fire.
- Connect the ground terminals on the SERVOPACK and Servomotor to ground poles according to local electrical codes (100 Ω or less for a SERVOPACK with a 100-VAC or 200-VAC power supply, and 10 Ω or less for a SERVOPACK with a 400-VAC power supply).
There is a risk of electric shock or fire.
- Do not attempt to disassemble, repair, or modify the product.
There is a risk of fire or failure.
The warranty is void for the product if you disassemble, repair, or modify it.



CAUTION

- The SERVOPACK heat sinks, regenerative resistors, External Dynamic Brake Resistors, Servomotors, and other components can be very hot while power is ON or soon after the power is turned OFF. Implement safety measures, such as installing covers, so that hands and parts such as cables do not come into contact with hot components.
There is a risk of burn injury.
- For a 24-VDC power supply, use a power supply device with double insulation or reinforced insulation.
There is a risk of electric shock.
- Do not damage, pull on, apply excessive force to, place heavy objects on, or pinch cables.
There is a risk of failure, damage, or electric shock.
- The person who designs the system that uses the hard wire base block safety function must have a complete knowledge of the related safety standards and a complete understanding of the instructions in this document.
There is a risk of injury, product damage, or machine damage.
- Do not use the product in an environment that is subject to water, corrosive gases, or flammable gases, or near flammable materials.
There is a risk of electric shock or fire.

NOTICE

- Do not attempt to use a SERVOPACK or Servomotor that is damaged or that has missing parts.
- Install external emergency stop circuits that shut OFF the power supply and stops operation immediately when an error occurs.
- In locations with poor power supply conditions, install the necessary protective devices (such as AC reactors) to ensure that the input power is supplied within the specified voltage range. There is a risk of damage to the SERVOPACK.
- Use a Noise Filter to minimize the effects of electromagnetic interference. Electronic devices used near the SERVOPACK may be affected by electromagnetic interference.
- Always use a Servomotor and SERVOPACK in one of the specified combinations.
- Do not touch a SERVOPACK or Servomotor with wet hands. There is a risk of product failure.

■ Storage Precautions



CAUTION

- Do not place an excessive load on the product during storage. (Follow all instructions on the packages.) There is a risk of injury or damage.

NOTICE

- Do not install or store the product in any of the following locations.
 - Locations that are subject to direct sunlight
 - Locations that are subject to ambient temperatures that exceed product specifications
 - Locations that are subject to relative humidities that exceed product specifications
 - Locations that are subject to condensation as the result of extreme changes in temperature
 - Locations that are subject to corrosive or flammable gases
 - Locations that are near flammable materials
 - Locations that are subject to dust, salts, or iron powder
 - Locations that are subject to water, oil, or chemicals
 - Locations that are subject to vibration or shock that exceeds product specifications
 - Locations that are subject to radiation
- If you store or install the product in any of the above locations, the product may fail or be damaged.

■ Transportation Precautions



CAUTION

- Transport the product in a way that is suitable to the mass of the product.
- Do not use the eyebolts on a SERVOPACK or Servomotor to move the machine. There is a risk of damage or injury.
- When you handle a SERVOPACK or Servomotor, be careful of sharp parts, such as the corners. There is a risk of injury.
- Do not place an excessive load on the product during transportation. (Follow all instructions on the packages.) There is a risk of injury or damage.

NOTICE

- Do not hold onto the front cover or connectors when you move a SERVOPACK.
There is a risk of the SERVOPACK falling.
- A SERVOPACK or Servomotor is a precision device. Do not drop it or subject it to strong shock.
There is a risk of failure or damage.
- Do not subject connectors to shock.
There is a risk of faulty connections or damage.
- If disinfectants or insecticides must be used to treat packing materials such as wooden frames, plywood, or pallets, the packing materials must be treated before the product is packaged, and methods other than fumigation must be used.
Example: Heat treatment, where materials are kiln-dried to a core temperature of 56°C for 30 minutes or more.
If the electronic products, which include stand-alone products and products installed in machines, are packed with fumigated wooden materials, the electrical components may be greatly damaged by the gases or fumes resulting from the fumigation process. In particular, disinfectants containing halogen, which includes chlorine, fluorine, bromine, or iodine can contribute to the erosion of the capacitors.
- Do not overtighten the eyebolts on a SERVOPACK or Servomotor.
If you use a tool to overtighten the eyebolts, the tapped holes may be damaged.

■ Installation Precautions



CAUTION

- Install the Servomotor or SERVOPACK in a way that will support the mass given in technical documents.
- Install SERVOPACKs, Servomotors, regenerative resistors, and External Dynamic Brake Resistors on nonflammable materials.
Installation directly onto or near flammable materials may result in fire.
- Provide the specified clearances between the SERVOPACK and the control panel as well as with other devices.
There is a risk of fire or failure.
- Install the SERVOPACK in the specified orientation.
There is a risk of fire or failure.
- Do not step on or place a heavy object on the product.
There is a risk of failure, damage, or injury.
- Do not allow any foreign matter to enter the SERVOPACK or Servomotor.
There is a risk of failure or fire.

NOTICE

- **Do not install or store the product in any of the following locations.**
 - Locations that are subject to direct sunlight
 - Locations that are subject to ambient temperatures that exceed product specifications
 - Locations that are subject to relative humidities that exceed product specifications
 - Locations that are subject to condensation as the result of extreme changes in temperature
 - Locations that are subject to corrosive or flammable gases
 - Locations that are near flammable materials
 - Locations that are subject to dust, salts, or iron powder
 - Locations that are subject to water, oil, or chemicals
 - Locations that are subject to vibration or shock that exceeds product specifications
 - Locations that are subject to radiationIf you store or install the product in any of the above locations, the product may fail or be damaged.
- **Use the product in an environment that is appropriate for the product specifications.**

If you use the product in an environment that exceeds product specifications, the product may fail or be damaged.
- **A SERVOPACK or Servomotor is a precision device. Do not drop it or subject it to strong shock.**

There is a risk of failure or damage.
- **Always install a SERVOPACK in a control panel.**
- **Do not allow any foreign matter to enter a SERVOPACK or a Servomotor with a Cooling Fan and do not cover the outlet from the Servomotor's cooling fan.**

There is a risk of failure.

■ Wiring Precautions



DANGER

- **Do not change any wiring while power is being supplied.**

There is a risk of electric shock or injury.



WARNING

- **Wiring and inspections must be performed only by qualified engineers.**

There is a risk of electric shock or product failure.
- **Check all wiring and power supplies carefully.**

Incorrect wiring or incorrect voltage application to the output circuits may cause short-circuit failures. If a short-circuit failure occurs as a result of any of these causes, the holding brake will not work. This could damage the machine or cause an accident that may result in death or injury.
- **Connect the AC and DC power supplies to the specified SERVOPACK terminals.**
 - Connect an AC power supply to the L1, L2, and L3 terminals and the L1C and L2C terminals on the SERVOPACK.
 - Connect a DC power supply to the B1/⊕ and ⊖2 terminals and the L1C and L2C terminals on the SERVOPACK.

There is a risk of failure or fire.
- **If you use a SERVOPACK that supports a Dynamic Brake Option, connect an External Dynamic Brake Resistor that is suitable for the machine and equipment specifications to the specified terminals.**

There is a risk of unexpected operation, machine damage, burning, or injury when an emergency stop is performed.



CAUTION

- Wait for six minutes after turning OFF the power supply and then make sure that the CHARGE indicator is not lit before starting wiring or inspection work. Do not touch the power supply terminals while the CHARGE lamp is lit after turning OFF the power supply because high voltage may still remain in the SERVOPACK.
There is a risk of electric shock.
- Observe the precautions and instructions for wiring and trial operation precisely as described in this document.
Failures caused by incorrect wiring or incorrect voltage application in the brake circuit may cause the SERVOPACK to fail, damage the equipment, or cause an accident resulting in death or injury.
- Check the wiring to be sure it has been performed correctly.
Connectors and pin layouts are sometimes different for different models. Always confirm the pin layouts in technical documents for your model before operation.
There is a risk of failure or malfunction.
- Connect wires to power supply terminals and motor connection terminals securely with the specified methods and tightening torque.
Insufficient tightening may cause wires and terminal blocks to generate heat due to faulty contact, possibly resulting in fire.
- Use shielded twisted-pair cables or screened unshielded multi-twisted-pair cables for I/O Signal Cables and Encoder Cables.
- Observe the following precautions when wiring the SERVOPACK's main circuit terminals.
 - Turn ON the power supply to the SERVOPACK only after all wiring, including the main circuit terminals, has been completed.
 - If a connector is used for the main circuit terminals, remove the main circuit connector from the SERVOPACK before you wire it.
 - Insert only one wire per insertion hole in the main circuit terminals.
 - When you insert a wire, make sure that the conductor wire (e.g., whiskers) does not come into contact with adjacent wires.
- Install molded-case circuit breakers and other safety measures to provide protection against short circuits in external wiring.
There is a risk of fire or failure.

NOTICE

- Whenever possible, use the Cables specified by Yaskawa.
If you use any other cables, confirm the rated current and application environment of your model and use the wiring materials specified by Yaskawa or equivalent materials.
- Securely tighten cable connector screws and lock mechanisms.
Insufficient tightening may result in cable connectors falling off during operation.
- Do not bundle power lines (e.g., the Main Circuit Cable) and low-current lines (e.g., the I/O Signal Cables or Encoder Cables) together or run them through the same duct. If you do not place power lines and low-current lines in separate ducts, separate them by at least 30 cm.
If the cables are too close to each other, malfunctions may occur due to noise affecting the low-current lines.
- Install a battery at either the host controller or on the Encoder Cable.
If you install batteries both at the host controller and on the Encoder Cable at the same time, you will create a loop circuit between the batteries, resulting in a risk of damage or burning.
- When connecting a battery, connect the polarity correctly.
There is a risk of battery rupture or encoder failure.

■ Operation Precautions



WARNING

- Before starting operation with a machine connected, change the settings of the switches and parameters to match the machine.
Unexpected machine operation, failure, or personal injury may occur if operation is started before appropriate settings are made.
- Do not radically change the settings of the parameters.
There is a risk of unstable operation, machine damage, or injury.
- Install limit switches or stoppers at the ends of the moving parts of the machine to prevent unexpected accidents.
There is a risk of machine damage or injury.
- For trial operation, securely mount the Servomotor and disconnect it from the machine.
There is a risk of injury.
- Forcing the motor to stop for overtravel is disabled when the Jog (Fn002), Origin Search (Fn003), or EasyFFT (Fn206) utility function is executed. Take necessary precautions.
There is a risk of machine damage or injury.
- When an alarm occurs, the Servomotor will coast to a stop or stop with the dynamic brake according to the SERVOPACK Option specifications and settings. The coasting distance will change with the moment of inertia of the load and the resistance of the External Dynamic Brake Resistor. Check the coasting distance during trial operation and implement suitable safety measures on the machine.
- Do not enter the machine's range of motion during operation.
There is a risk of injury.
- Do not touch the moving parts of the Servomotor or machine during operation.
There is a risk of injury.



CAUTION

- Design the system to ensure safety even when problems, such as broken signal lines, occur. For example, the P-OT and N-OT signals are set in the default settings to operate on the safe side if a signal line breaks. Do not change the polarity of this type of signal.
- When overtravel occurs, the power supply to the motor is turned OFF and the brake is released. If you use the Servomotor to drive a vertical load, set the Servomotor to enter a zero-clamped state after the Servomotor stops. Also, install safety devices (such as an external brake or counterweight) to prevent the moving parts of the machine from falling.
- Always turn OFF the servo before you turn OFF the power supply. If you turn OFF the main circuit power supply or control power supply during operation before you turn OFF the servo, the Servomotor will stop as follows:
 - If you turn OFF the main circuit power supply during operation without turning OFF the servo, the Servomotor will stop abruptly with the dynamic brake.
 - If you turn OFF the control power supply without turning OFF the servo, the stopping method that is used by the Servomotor depends on the model of the SERVOPACK. For details, refer to the manual for the SERVOPACK.
 - If you use a SERVOPACK that supports a Dynamic Brake Option, the Servomotor stopping methods will be different from the stopping methods used without the Option or for other Hardware Option specifications. For details, refer to the *Σ-7-Series AC Servo Drive Σ-7S/Σ-7W SERVOPACK with Hardware Option Specifications Dynamic Brake Product Manual*.
- Do not use the dynamic brake for any application other than an emergency stop.
There is a risk of failure due to rapid deterioration of elements in the SERVOPACK and the risk of unexpected operation, machine damage, burning, or injury.

NOTICE

- When you adjust the gain during system commissioning, use a measuring instrument to monitor the torque waveform and speed waveform and confirm that there is no vibration.
If a high gain causes vibration, the Servomotor will be damaged quickly.
- Do not frequently turn the power supply ON and OFF. After you have started actual operation, allow at least one hour between turning the power supply ON and OFF (as a guideline).
Do not use the product in applications that require the power supply to be turned ON and OFF frequently.
The elements in the SERVOPACK will deteriorate quickly.
- An alarm or warning may occur if communications are performed with the host controller while the SigmaWin+ or Digital Operator is operating.
If an alarm or warning occurs, it may interrupt the current process and stop the system.
- After you complete trial operation of the machine and facilities, use the SigmaWin+ to back up the settings of the SERVOPACK parameters. You can use them to reset the parameters after SERVOPACK replacement.
If you do not copy backed up parameter settings, normal operation may not be possible after a faulty SERVOPACK is replaced, possibly resulting in machine or equipment damage.

■ Maintenance and Inspection Precautions

DANGER

- Do not change any wiring while power is being supplied.
There is a risk of electric shock or injury.

WARNING

- Wiring and inspections must be performed only by qualified engineers.
There is a risk of electric shock or product failure.

CAUTION

- Wait for six minutes after turning OFF the power supply and then make sure that the CHARGE indicator is not lit before starting wiring or inspection work. Do not touch the power supply terminals while the CHARGE lamp is lit after turning OFF the power supply because high voltage may still remain in the SERVOPACK.
There is a risk of electric shock.
- Before you replace a SERVOPACK, back up the settings of the SERVOPACK parameters. Copy the backed up parameter settings to the new SERVOPACK and confirm that they were copied correctly.
If you do not copy backed up parameter settings or if the copy operation is not completed normally, normal operation may not be possible, possibly resulting in machine or equipment damage.

NOTICE

- Discharge all static electricity from your body before you operate any of the buttons or switches inside the front cover of the SERVOPACK.
There is a risk of equipment damage.

■ Troubleshooting Precautions



DANGER

- If the safety device (molded-case circuit breaker or fuse) installed in the power supply line operates, remove the cause before you supply power to the SERVOPACK again. If necessary, repair or replace the SERVOPACK, check the wiring, and remove the factor that caused the safety device to operate.

There is a risk of fire, electric shock, or injury.



WARNING

- The product may suddenly start to operate when the power supply is recovered after a momentary power interruption. Design the machine to ensure human safety when operation restarts.

There is a risk of injury.



CAUTION

- When an alarm occurs, remove the cause of the alarm and ensure safety. Then reset the alarm or turn the power supply OFF and ON again to restart operation.
There is a risk of injury or machine damage.
- If the Servo ON signal is input to the SERVOPACK and an alarm is reset, the Servomotor may suddenly restart operation. Confirm that the servo is OFF and ensure safety before you reset an alarm.
There is a risk of injury or machine damage.
- Always insert a magnetic contactor in the line between the main circuit power supply and the main circuit power supply terminals on the SERVOPACK so that the power supply can be shut OFF at the main circuit power supply.
If a magnetic contactor is not connected when the SERVOPACK fails, a large current may flow, possibly resulting in fire.
- If an alarm occurs, shut OFF the main circuit power supply.
There is a risk of fire due to a regenerative resistor overheating as the result of regenerative transistor failure.
- Install a ground fault detector against overloads and short-circuiting or install a molded-case circuit breaker combined with a ground fault detector.
There is a risk of SERVOPACK failure or fire if a ground fault occurs.
- The holding brake on a Servomotor will not ensure safety if there is the possibility that an external force (including gravity) may move the current position and create a hazardous situation when power is interrupted or an error occurs. If an external force may cause movement, install an external braking mechanism that ensures safety.

■ Disposal Precautions

- When disposing of the product, treat it as ordinary industrial waste. However, local ordinances and national laws must be observed. Implement all labeling and warnings as a final product as required.

■ General Precautions

- Figures provided in this document are typical examples or conceptual representations. There may be differences between them and actual wiring, circuits, and products.
- The products shown in illustrations in this document are sometimes shown without covers or protective guards. Always replace all covers and protective guards before you use the product.
- If you need a new copy of this document because it has been lost or damaged, contact your nearest Yaskawa representative or one of the offices listed on the back of this document.
- This document is subject to change without notice for product improvements, specifications changes, and improvements to the manual itself.
We will update the document number of the document and issue revisions when changes are made.
- Any and all quality guarantees provided by Yaskawa are null and void if the customer modifies the product in any way. Yaskawa disavows any responsibility for damages or losses that are caused by modified products.

Warranty

◆ Details of Warranty

■ Warranty Period

The warranty period for a product that was purchased (hereinafter called the “delivered product”) is one year from the time of delivery to the location specified by the customer or 18 months from the time of shipment from the Yaskawa factory, whichever is sooner.

■ Warranty Scope

Yaskawa shall replace or repair a defective product free of charge if a defect attributable to Yaskawa occurs during the above warranty period.

This warranty does not cover defects caused by the delivered product reaching the end of its service life and replacement of parts that require replacement or that have a limited service life.

This warranty does not cover failures that result from any of the following causes.

- Improper handling, abuse, or use in unsuitable conditions or in environments not described in product catalogs or manuals, or in any separately agreed-upon specifications
- Causes not attributable to the delivered product itself
- Modifications or repairs not performed by Yaskawa
- Use of the delivered product in a manner in which it was not originally intended
- Causes that were not foreseeable with the scientific and technological understanding at the time of shipment from Yaskawa
- Events for which Yaskawa is not responsible, such as natural or human-made disasters

◆ Limitations of Liability

- Yaskawa shall in no event be responsible for any damage or loss of opportunity to the customer that arises due to failure of the delivered product.
- Yaskawa shall not be responsible for any programs (including parameter settings) or the results of program execution of the programs provided by the user or by a third party for use with programmable Yaskawa products.
- The information described in product catalogs or manuals is provided for the purpose of the customer purchasing the appropriate product for the intended application. The use thereof does not guarantee that there are no infringements of intellectual property rights or other proprietary rights of Yaskawa or third parties, nor does it construe a license.
- Yaskawa shall not be responsible for any damage arising from infringements of intellectual property rights or other proprietary rights of third parties as a result of using the information described in catalogs or manuals.

◆ Suitability for Use

- It is the customer's responsibility to confirm conformity with any standards, codes, or regulations that apply if the Yaskawa product is used in combination with any other products.
- The customer must confirm that the Yaskawa product is suitable for the systems, machines, and equipment used by the customer.
- Consult with Yaskawa to determine whether use in the following applications is acceptable. If use in the application is acceptable, use the product with extra allowance in ratings and specifications, and provide safety measures to minimize hazards in the event of failure.
 - Outdoor use, use involving potential chemical contamination or electrical interference, or use in conditions or environments not described in product catalogs or manuals
 - Nuclear energy control systems, combustion systems, railroad systems, aviation systems, vehicle systems, medical equipment, amusement machines, and installations subject to separate industry or government regulations
 - Systems, machines, and equipment that may present a risk to life or property
 - Systems that require a high degree of reliability, such as systems that supply gas, water, or electricity, or systems that operate continuously 24 hours a day
 - Other systems that require a similar high degree of safety
- Never use the product for an application involving serious risk to life or property without first ensuring that the system is designed to secure the required level of safety with risk warnings and redundancy, and that the Yaskawa product is properly rated and installed.
- The circuit examples and other application examples described in product catalogs and manuals are for reference. Check the functionality and safety of the actual devices and equipment to be used before using the product.
- Read and understand all use prohibitions and precautions, and operate the Yaskawa product correctly to prevent accidental harm to third parties.

◆ Specifications Change

The names, specifications, appearance, and accessories of products in product catalogs and manuals may be changed at any time based on improvements and other reasons. The next editions of the revised catalogs or manuals will be published with updated code numbers. Consult with your Yaskawa representative to confirm the actual specifications before purchasing a product.

Compliance with UL Standards, EU Directives, and Other Safety Standards

Certification marks for the standards for which the product has been certified by certification bodies are shown on nameplate. Products that do not have the marks are not certified for the standards.

◆ North American Safety Standards (UL)



Product	Model	North American Safety Standards (UL File No.)
SERVOPACKs	SGD7S	UL 61800-5-1 (E147823) CSA C22.2 No.274
Rotary Servomotors	<ul style="list-style-type: none"> • SGMMV • SGM7A • SGM7J • SGM7P • SGM7G 	UL 1004-1 UL 1004-6 (E165827)
Direct Drive Servomotors	SGMCS	UL 1004-1 UL 1004-6 (E165827)
	SGMCMV*1	UL 1004-1 UL 1004-6
Linear Servomotors	<ul style="list-style-type: none"> • SGLGW • SGLFW • SGLFW2*2 • SGLTW 	UL 1004 (E165827)

*1. Certification is scheduled for December 2015.

*2. Certification is scheduled for March 2016.

◆ European Directives



Product	Model	European Directive	Harmonized Standards
SERVOPACKs	SGD7S	Machinery Directive 2006/42/EC	EN ISO13849-1: 2008/AC: 2009
		EMC Directive 2004/108/EC	EN 55011 group 1, class A EN 61000-6-2 EN 61000-6-4 EN 61800-3
		Low Voltage Directive 2006/95/EC	EN 50178 EN 61800-5-1
Rotary Servomotors	<ul style="list-style-type: none"> • SGM7J • SGM7A • SGM7P • SGM7G 	EMC Directive 2004/108/EC	EN 55011 group 1, class A EN 61000-6-2 EN 61000-6-4 EN 61800-3
		Low Voltage Directive 2006/95/EC	EN 60034-1 EN 60034-5
Direct Drive Servomotors	<ul style="list-style-type: none"> • SGMCS- □□B, □□C, □□D, □□E (Small-Capacity, Coreless Servomotors) • SGMCV 	EMC Directive 2004/108/EC	EN 55011 group 1, class A EN 61000-6-2 EN 61800-3*1
		Low Voltage Directive 2006/95/EC	EN 60034-1 EN 60034-5
Linear Servomotors	<ul style="list-style-type: none"> • SGLG • SGLF • SGLFW2*2 • SGLT • SGLC 	EMC Directive 2004/108/EC	EN 55011 group 1, class A EN 61000-6-2 EN 61000-6-4 EN 61800-3
		Low Voltage Directive 2006/95/EC	EN 60034-1

*1. Only the SGMCV is certified.

*2. Certification is scheduled for September 2015.

Note: We declared the CE Marking based on the harmonized standards in the above table.

◆ Safety Standards



Product	Model	Safety Standards	Standards
SERVOPACKs	SGD7S	Safety of Machinery	EN ISO13849-1: 2008/AC: 2009 IEC 60204-1
		Functional Safety	IEC 61508 series IEC 62061 IEC 61800-5-2
		EMC	IEC 61326-3-1

◆ Safety Parameters

Item	Standards	Performance Level
Safety Integrity Level	IEC 61508	SIL3
	IEC 62061	SILCL3
Probability of Dangerous Failure per Hour	IEC 61508 IEC 62061	PFH = 4.04×10^{-9} [1/h] (4.04% of SIL3)
Performance Level	EN ISO 13849-1	PLe (Category 3)
Mean Time to Dangerous Failure of Each Channel	EN ISO 13849-1	MTTFd: High
Average Diagnostic Coverage	EN ISO 13849-1	DCavg: Medium
Stop Category	IEC 60204-1	Stop category 0
Safety Function	IEC 61800-5-2	STO
Mission Time	IEC 61508	10 years
Hardware Fault Tolerance	IEC 61508	HFT = 1
Subsystem	IEC 61508	B

Contents

About this Manual	iii
Outline of Manual	iii
Related Documents	vi
Using This Manual	x
Safety Precautions	xiii
Warranty	xxiii
Compliance with UL Standards, EU Directives, and Other Safety Standards. . .	xxv

1

Basic Information on SERVOPACKs

1.1	Product Introduction	1-2
1.1.1	Main Features	1-2
1.1.2	Main Functions	1-2
1.2	Model Designations	1-3
1.2.1	Interpreting SERVOPACK Model Numbers	1-3
1.2.2	Interpreting Servomotor Model Numbers	1-3
1.3	Combinations of SERVOPACKs and Servomotors	1-4
1.4	Functions	1-5
1.5	SigmaWin+	1-8

2

SERVOPACK Ratings and Specifications

2.1	Ratings	2-2
2.2	SERVOPACK Overload Protection Characteristics	2-4
2.3	Specifications	2-5

3

Wiring and Connecting SERVOPACKs

3.1	Basic Wiring Diagrams	3-2
3.2	I/O Signal Connections	3-4
3.2.1	I/O Signal Connector (CN1) Names and Functions	3-4
3.2.2	I/O Signal Connector (CN1) Pin Arrangement	3-7

4

Trial Operation

4.1	Trial Operation Example	4-2
------------	--	------------

5

Monitoring

5.1	Monitoring SERVOPACK Status	5-2
5.1.1	Monitoring Status and Operations	5-2
5.1.2	I/O Signal Monitor	5-4
5.2	Monitoring Machine Operation Status and Signal Waveforms . .	5-5

6

Settings

6.1	Control Method Selection	6-2
6.2	I/O Signal Allocations	6-3
6.2.1	Input Signal Allocations	6-3
6.2.2	Output Signal Allocations	6-5
6.3	Moving Mode and Coordinate Settings	6-8
6.3.1	When the Coordinates are the Linear Type	6-8
6.3.2	When the Coordinates are the Rotary Type	6-9
6.4	Settings for References	6-10
6.4.1	Motor Speed	6-10
6.4.2	Acceleration Rate and Deceleration Rate	6-10
6.4.3	Smoothing	6-11
6.5	Origin Settings	6-12
6.5.1	When Using an Absolute Encoder	6-12
6.5.2	When Using an Incremental Encoder	6-13

7

Operation with Digital I/O

7.1	Operation Functions	7-3
7.2	Homing	7-4
7.2.1	I/O Signals Related to Homing	7-4
7.2.2	Parameters Related to Homing	7-5
7.2.3	Homing Procedures	7-7
7.3	Program Table Operation	7-9
7.3.1	Types of Operation	7-9
7.3.2	I/O Signals Related to Program Table Operation	7-11
7.3.3	Program Table Configuration	7-12
7.3.4	Settings in the Program Table	7-13
7.3.5	SigmaWin+ Procedures	7-14
7.3.6	State Transitions	7-26
7.3.7	Program Table Operation Examples	7-27
7.3.8	EVENT Examples	7-42
7.3.9	Output Response Times after /START-STOP Turns ON	7-43

7.4	Jog Speed Table Operation	7-44
7.4.1	Input Signals Related to Jog Operation	7-44
7.4.2	Jog Speeds	7-44
7.4.3	Jog Speed Table and Speed Selection Signals	7-45
7.4.4	SigmaWin+ Procedures	7-46
7.4.5	Jog Speed Table Operation Example	7-51
7.4.6	Timing of Signal Changes	7-52
7.5	ZONE Outputs	7-53
7.5.1	ZONE Table and ZONE Signals	7-53
7.5.2	Parameters Related to ZONE Signals	7-54
7.5.3	SigmaWin+ Procedures	7-55

8

Maintenance

8.1	Alarm Displays	8-2
8.1.1	List of Alarms	8-2
8.1.2	Troubleshooting Alarms	8-8
8.1.3	INDEXER Alarm Displays and Troubleshooting	8-36
8.2	Warning Displays	8-38
8.2.1	List of Warnings	8-38
8.2.2	Troubleshooting Warnings	8-40
8.2.3	INDEXER Warning Displays and Troubleshooting	8-45
8.3	Troubleshooting Based on the Operation and Conditions of the Servomotor.	8-49

9

Parameter Lists

9.1	Parameter Configurations	9-2
9.2	List of Parameters	9-3
9.2.1	Interpreting the Parameter Lists	9-3
9.2.2	List of Parameters	9-4

10

Appendices

10.1	Corresponding SERVOPACK and SigmaWin+ Function Names	10-2
10.1.1	Corresponding SERVOPACK Utility Function Names	10-2
10.1.2	Corresponding SERVOPACK Monitor Display Function Names	10-3
10.2	Operation of Digital Operator	10-6
10.2.1	Overview	10-6
10.2.2	Operation of Utility Functions	10-7

Index

Revision History

Basic Information on SERVOPACKs

1

This chapter provides basic information, including an introduction to the product, and describes how to interpret model numbers and combinations with Servomotors.

1.1	Product Introduction	1-2
1.1.1	Main Features	1-2
1.1.2	Main Functions	1-2
1.2	Model Designations	1-3
1.2.1	Interpreting SERVOPACK Model Numbers	1-3
1.2.2	Interpreting Servomotor Model Numbers	1-3
1.3	Combinations of SERVOPACKs and Servomotors . .	1-4
1.4	Functions	1-5
1.5	SigmaWin+	1-8

1.1 Product Introduction

The SERVOPACKs described in this manual are for positioning and contain a built-in INDEXER.

1.1.1 Main Features

This section describes the main features.

- You can achieve high-speed, high-precision positioning without using a motion controller. A host controller can be easily connected through digital I/O signals.
- Motion control can be easily achieved simply by setting positions and speeds in a program table or jog speed table.
- The SigmaWin+ Engineering Tool can be used for everything from making adjustments to editing the program table and jog speed table.

1.1.2 Main Functions

This section describes the main functions.

Function Name	Function Overview
Program Table	With program table operation, you can register positioning operation patterns in a table in the SERVOPACK in advance and then use digital I/O signals with the host controller to specify the operation patterns to perform operation. You can save up to 256 program steps. Program steps can be linked to each other to create complex movements.
Homing and Jog Speed Table	You can perform homing when an incremental encoder is used, or you can perform jog operation with a jog speed table that contains up to eight jog speeds.
Registration	The program table supports registration (external positioning).
Programmable Output Signals	You can specify the output status of up to five output signals (/POUT0 to /POUT4).
ZONE Table	You can use the programmable output signals (/POUT0 to /POUT2) as the ZONE signals. You can specify up to eight ZONES in the ZONE table.

1.2 Model Designations

1.2.1 Interpreting SERVOPACK Model Numbers

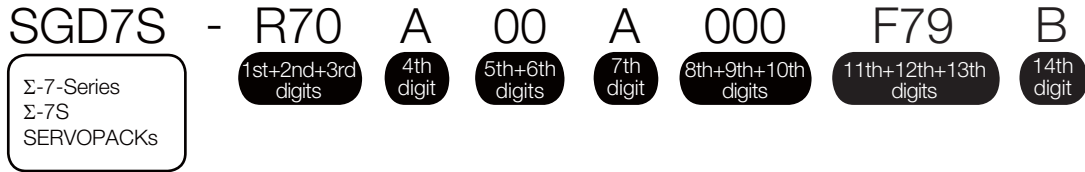

1st+2nd+3rd digits Maximum Applicable Motor Capacity

Voltage	Code	Specification
Three-Phase, 200 VAC	R70* ¹	0.05 kW
	R90* ¹	0.1 kW
	1R6* ¹	0.2 kW
	2R8* ¹	0.4 kW
	3R8	0.5 kW
	5R5* ¹	0.75 kW
	7R6	1.0 kW
	120* ²	1.5 kW
	180	2.0 kW
	200	3.0 kW
	330	5.0 kW
	470	6.0 kW
	550	7.5 kW
590	11 kW	
780	15 kW	

4th digit Voltage

Code	Specification
A	200 VAC

5th+6th digits Interface *³

Code	Specification
00	Analog voltage/pulse train reference

7th digit Design Revision Order
A

8th+9th+10th digits Hardware Options Specification

Code	Specification	Applicable Models
000	Without options	All models
001	Rack-mounted	SGD7S-R70A to -330A
	Duct-ventilated	SGD7S-470A to -780A
002	Varnished	All models
008	Single-phase, 200-VAC power supply input	SGD7S-120A

11th+12th+13th digits FT/EX Specification

Code	Specification
F79	Indexing applications

14th digit BTO Specification*⁴

Code	Specification
None	None
B	BTO specification

- *1. You can use these models with either a single-phase or three-phase input.
- *2. A model with a single-phase, 200-VAC power supply input is available as a hardware option (model: SGD7S-120A00A008).
- *3. The same SERVOPACKs are used for both Rotary Servomotors and Linear Servomotors.
- *4. The BTO specification indicates if the SERVOPACK is customized by using the MechatroCloud BTO service. You need a BTO number to order SERVOPACKs with customized specifications. Refer to the following catalog for details on the BTO specification.
📖 AC Servo Drives Σ-7 Series (Manual No.: KAEP S800001 23)

1.2.2 Interpreting Servomotor Model Numbers

This section outlines the model numbers of Σ-7-series Servomotors. Refer to the relevant manual in the following list for details.

- 📖 Σ-7-Series Rotary Servomotor Product Manual (Manual No.: SIEP S800001 36)
- 📖 Σ-7-Series Linear Servomotor Product Manual (Manual No.: SIEP S800001 37)
- 📖 Σ-7-Series Direct Drive Servomotor Product Manual (Manual No.: SIEP S800001 38)

1.3 Combinations of SERVOPACKs and Servomotors

Refer to the following manuals for information on combinations with Σ -7-Series Servomotors.

 Σ -7-Series Rotary Servomotor Product Manual (Manual No.: SIEP S800001 36)

 Σ -7-Series Linear Servomotor Product Manual (Manual No.: SIEP S800001 37)

 Σ -7-Series Direct Drive Servomotor Product Manual (Manual No.: SIEP S800001 38)

1.4 Functions

This section lists the functions provided by SERVOPACKs. Refer to this manual and the following manuals for details on the functions.

📖 Σ -7-Series Σ -7S SERVOPACK with Analog Voltage/Pulse Train References Product Manual (Manual No.: SIEP S800001 26)

- **Functions Related to the Machine**

Function
Power Supply Type Settings for the Main Circuit and Control Circuit
Automatic Detection of Connected Motor
Motor Direction Setting
Linear Encoder Pitch Setting
Writing Linear Servomotor Parameters
Selecting the Phase Sequence for a Linear Servomotor
Polarity Sensor Setting
Polarity Detection
Overtravel Function and Settings
Holding Brake
Motor Stopping Methods for Servo OFF and Alarms
Resetting the Absolute Encoder
Setting the Origin of the Absolute Encoder
Setting the Regenerative Resistor Capacity
Operation for Momentary Power Interruptions
SEMI F47 Function
Setting the Motor Maximum Speed
Multiturn Limit Setting
Adjustment of Motor Current Detection Signal Offset
Forcing the Motor to Stop
Speed Ripple Compensation
Current Control Mode Selection
Current Gain Level Setting
Speed Detection Method Selection
Fully-Closed Loop Control
Safety Functions

- **Functions Related to the Host Controller**

Function
Electronic Gear Settings
I/O Signal Allocations
Servo Alarm (ALM) Signal
Alarm Code (ALO1 to ALO3) Signals
Warning Output (/WARN) Signal
Rotation Detection (/TGON) Signal
/S-RDY (Servo Ready) Signal
Speed Control
Basic Settings for Speed Control
Speed Reference Filter
Zero Clamping
Speed Coincidence Detection (/V-CMP) Signal
Position Control
Reference Pulse Form

Continued on next page.

Continued from previous page.

Function
Position Deviation Clear Input (CLR) Signal Function and Settings
Reference Pulse Input Multiplication Switching
Positioning Completion (/COIN) Signal
Near (/NEAR) Signal
Reference Pulse Inhibition and Settings
Torque Control
Basic Settings for Torque Control
Torque Reference Filter Settings
Speed Limit during Torque Control
Speed Limit Detection (/VLT) Signal
Encoder Divided Pulse Output
Selecting Torque Limits
Vibration Detection Level Initialization
Alarm Reset
Replacing the Battery
Setting the Position Deviation Overflow Alarm Level

• **Functions to Achieve Optimum Motions**

Function
Speed Control
Soft Start Settings
Position Control
Smoothing Settings
Torque Control
Tuning-less Function
Automatic Adjustment without a Host Reference
Automatic Adjustment with a Host Reference
Custom Adjustment
Anti-Resonance Control Adjustment
Vibration Suppression
Gain Selection
Friction Compensation
Model Following Control
Compatible Adjustment Functions
Mechanical Analysis
EasyFFT

• **Functions for Trial Operation during Setup**

Function
Software Reset
Trial Operation of Servomotor without a Load
Program Jog Operation
Origin Search
Test without a Motor
Monitoring Machine Operation Status and Signal Waveforms

- Functions for Inspection and Maintenance

Function
Write Prohibition Setting for Parameters
Initializing Parameter Settings
Automatic Detection of Connected Motor
Monitoring Product Information
Monitoring Product Life
Alarm History Display

- Operation with Digital I/O

Function
Homing
Positioning Operations with a Program Table
Registration
Constant Speed Operations with a Jog Speed Table
ZONE Outputs

1.5 SigmaWin+

To use the SigmaWin+, a model information file must be added to SigmaWin+ version 7.10 or higher.

Add the FT79 model information file to SigmaWin+ version 7.10 or higher to use the SigmaWin+.

SERVOPACK Ratings and Specifications

2

This chapter provides information required to select SERVOPACKs, such as specifications.

2.1	Ratings	2-2
2.2	SERVOPACK Overload Protection Characteristics ..	2-4
2.3	Specifications	2-5

2.1 Ratings

Three-Phase, 200 VAC

Model SGD7S-		R70A	R90A	1R6A	2R8A	3R8A	5R5A	7R6A	120A	180A	200A	330A	
Maximum Applicable Motor Capacity [kW]		0.05	0.1	0.2	0.4	0.5	0.75	1.0	1.5	2.0	3.0	5.0	
Continuous Output Current [Arms]		0.66	0.91	1.6	2.8	3.8	5.5	7.6	11.6	18.5	19.6	32.9	
Instantaneous Maximum Output Current [Arms]		2.1	3.2	5.9	9.3	11	16.9	17	28	42	56	84	
Main Circuit	Power Supply	200 VAC to 240 VAC, -15% to +10%, 50 Hz/60 Hz											
	Input Current [Arms]*	0.4	0.8	1.3	2.5	3.0	4.1	5.7	7.3	10	15	25	
Control Power Supply		200 VAC to 240 VAC, -15% to +10%, 50 Hz/60 Hz											
Power Supply Capacity [kVA]*		0.2	0.3	0.5	1.0	1.3	1.6	2.3	3.2	4.0	5.9	7.5	
Power Loss*	Main Circuit Power Loss [W]	5.0	7.0	11.9	22.5	28.5	38.9	49.2	72.6	104.2	114.2	226.6	
	Control Circuit Power Loss [W]	12	12	12	12	14	14	14	15	16	16	19	
	Built-in Regenerative Resistor Power Loss [W]	–	–	–	–	8	8	8	10	16	16	36	
	Total Power Loss [W]	17.0	19.0	23.9	34.5	50.5	60.9	71.2	97.6	136.2	146.2	281.6	
Regenerative Resistor	Built-In Regenerative Resistor	Resistance [Ω]	–	–	–	–	40	40	40	20	12	12	8
		Capacity [W]	–	–	–	–	40	40	40	60	60	60	180
	Minimum Allowable External Resistance [Ω]	40	40	40	40	40	40	40	40	20	12	12	8
Overvoltage Category		III											

* This is the net value at the rated load.

Model SGD7S-		470A	550A	590A	780A	
Maximum Applicable Motor Capacity [kW]		6.0	7.5	11	15	
Continuous Output Current [Arms]		46.9	54.7	58.6	78.0	
Instantaneous Maximum Output Current [Arms]		110	130	140	170	
Main Circuit	Power Supply	200 VAC to 240 VAC, -15% to +10%, 50 Hz/60 Hz				
	Input Current [Arms]* ¹	29	37	54	73	
Control Power Supply		200 VAC to 240 VAC, -15% to +10%, 50 Hz/60 Hz				
Power Supply Capacity [kVA]* ¹		10.7	14.6	21.7	29.6	
Power Loss* ¹	Main Circuit Power Loss [W]	271.7	326.9	365.3	501.4	
	Control Circuit Power Loss [W]	21	21	28	28	
	External Regenerative Resistor Power Loss [W]	180* ²	350* ³	350* ³	350* ³	
	Total Power Loss [W]	292.7	347.9	393.3	529.4	
Regenerative Resistor	External Regenerative Resistor	Resistance [Ω]	6.25* ²	3.13* ³	3.13* ³	3.13* ³
		Capacity [W]	880* ²	1760* ³	1760* ³	1760* ³
	Minimum Allowable External Resistance [Ω]	5.8	2.9	2.9	2.9	
Overvoltage Category		III				

*1. This is the net value at the rated load.

*2. This value is for the optional JUSP-RA04-E Regenerative Resistor Unit.

*3. This value is for the optional JUSP-RA05-E Regenerative Resistor Unit.

Single-Phase, 200 VAC

Model SGD7S-		R70A	R90A	1R6A	2R8A	5R5A	120A	
Maximum Applicable Motor Capacity [kW]		0.05	0.1	0.2	0.4	0.75	1.5	
Continuous Output Current [Arms]		0.66	0.91	1.6	2.8	5.5	11.6	
Instantaneous Maximum Output Current [Arms]		2.1	3.2	5.9	9.3	16.9	28	
Main Circuit	Power Supply	200 VAC to 240 VAC, -15% to +10%, 50 Hz/60 Hz						
	Input Current [Arms]*	0.8	1.6	2.4	5.0	8.7	16	
Control Power Supply		200 VAC to 240 VAC, -15% to +10%, 50 Hz/60 Hz						
Power Supply Capacity [kVA]*		0.2	0.3	0.6	1.2	1.9	4.0	
Power Loss*	Main Circuit Power Loss [W]	5.0	7.1	12.1	23.7	39.2	71.8	
	Control Circuit Power Loss [W]	12	12	12	12	14	16	
	Built-in Regenerative Resistor Power Loss [W]	–	–	–	–	8	16	
	Total Power Loss [W]	17.0	19.1	24.1	35.7	61.2	103.8	
Regenerative Resistor	Built-In Regenerative Resistor	Resistance [Ω]	–	–	–	–	40	12
		Capacity [W]	–	–	–	–	40	60
	Minimum Allowable External Resistance [Ω]	40	40	40	40	40	40	12
Overvoltage Category		III						

* This is the net value at the rated load.

270 VDC

Model SGD7S-		R70A	R90A	1R6A	2R8A	3R8A	5R5A	7R6A	120A
Maximum Applicable Motor Capacity [kW]		0.05	0.1	0.2	0.4	0.5	0.75	1.0	1.5
Continuous Output Current [Arms]		0.66	0.91	1.6	2.8	3.8	5.5	7.6	11.6
Instantaneous Maximum Output Current [Arms]		2.1	3.2	5.9	9.3	11.0	16.9	17.0	28.0
Main Circuit	Power Supply	270 VDC to 324 VDC, -15% to +10%							
	Input Current [Arms]*	0.5	1.0	1.5	3.0	3.8	4.9	6.9	11
Control Power Supply		270 VDC to 324 VDC, -15% to +10%							
Power Supply Capacity [kVA]*		0.2	0.3	0.6	1	1.4	1.6	2.3	3.2
Power Loss*	Main Circuit Power Loss [W]	4.4	5.9	9.8	17.5	23.0	30.7	38.7	55.8
	Control Circuit Power Loss [W]	12	12	12	12	14	14	14	15
	Total Power Loss [W]	16.4	17.9	21.8	29.5	37.0	44.7	52.7	70.8
Overvoltage Category		III							

* This is the net value at the rated load.

Model SGD7S-		180A	200A	330A	470A	550A	590A	780A
Maximum Applicable Motor Capacity [kW]		2.0	3.0	5.0	6.0	7.5	11.0	15.0
Continuous Output Current [Arms]		18.5	19.6	32.9	46.9	54.7	58.6	78.0
Instantaneous Maximum Output Current [Arms]		42.0	56.0	84.0	110	130	140	170
Main Circuit	Power Supply	270 VDC to 324 VDC, -15% to +10%						
	Input Current [Arms]*	14	20	34	36	48	68	92
Control Power Supply		270 VDC to 324 VDC, -15% to +10%						
Power Supply Capacity [kVA]*		4.0	5.9	7.5	10.7	14.6	21.7	29.6
Power Loss*	Main Circuit Power Loss [W]	82.7	83.5	146.2	211.6	255.3	243.6	343.4
	Control Circuit Power Loss [W]	16	16	19	21	21	28	28
	Total Power Loss [W]	98.7	99.5	165.2	232.6	276.3	271.6	371.4
Overvoltage Category		III						

* This is the net value at the rated load.

2.2

SERVOPACK Overload Protection Characteristics

The overload detection level is set for hot start conditions with a SERVOPACK surrounding air temperature of 55°C.

An overload alarm (A.710 or A.720) will occur if overload operation that exceeds the overload protection characteristics shown in the following diagram (i.e., operation on the right side of the applicable line) is performed.

The actual overload detection level will be the detection level of the connected SERVOPACK or Servomotor that has the lower overload protection characteristics.

In most cases, that will be the overload protection characteristics of the Servomotor.

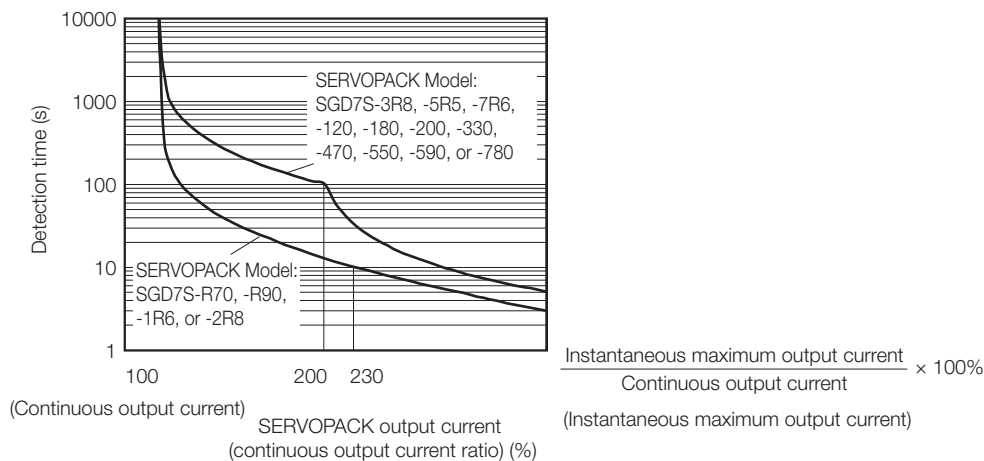

Note: The above overload protection characteristics do not mean that you can perform continuous duty operation with an output of 100% or higher.

For a Yaskawa-specified combination of SERVOPACK and Servomotor, maintain the effective torque within the continuous duty zone of the torque-motor speed characteristic of the Servomotor.

2.3 Specifications

The product specifications are given below.

Item		Specification
Control Method		IGBT-based PWM control, sine wave current drive
Feedback	With Rotary Servomotor	Serial encoder: 20 bits or 24 bits (incremental encoder/ absolute encoder) 22 bits (absolute encoder)
	With Linear Servomotor	<ul style="list-style-type: none"> Absolute linear encoder (The signal resolution depends on the absolute linear encoder.) Incremental linear encoder (The signal resolution depends on the incremental linear encoder or Serial Converter Unit.)
Environmental Conditions	Surrounding Air Temperature* ¹	0°C to 55°C
	Storage Temperature	-20°C to 85°C
	Surrounding Air Humidity	90% relative humidity max. (with no freezing or condensation)
	Storage Humidity	90% relative humidity max. (with no freezing or condensation)
	Vibration Resistance	4.9 m/s ²
	Shock Resistance	19.6 m/s ²
	Degree of Protection	IP10
	Pollution Degree	2 <ul style="list-style-type: none"> Must be no corrosive or flammable gases. Must be no exposure to water, oil, or chemicals. Must be no dust, salts, or iron dust.
	Altitude* ¹	1,000 m max.
Others	Do not use the SERVOPACK in the following locations: Locations subject to static electricity noise, strong electromagnetic/magnetic fields, or radioactivity	
Applicable Standards		Refer to the following section for details.  Compliance with UL Standards, EU Directives, and Other Safety Standards on page xxv
Mounting	Mounting	SERVOPACK Model: SGD7S-
	Base-mounted	All Models
	Rack-mounted	R70A, R90A, 1R6A, 2R8A, 3R8A, 5R5A, 7R6A, 120A, 180A, 200A, 330A
	Duct-ventilated	470A, 550A, 590A, 780A
Performance	Speed Control Range	1:5000 (At the rated torque, the lower limit of the speed control range must not cause the Servomotor to stop.)
	Coefficient of Speed Fluctuation* ²	±0.01% of rated speed max. (for a load fluctuation of 0% to 100%)
		0% of rated speed max. (for a load fluctuation of ±10%)
		±0.1% of rated speed max. (for a temperature fluctuation of 25°C ±25°C)
Torque Control Precision (Repeatability)	±1%	
Soft Start Time Setting	0 s to 10 s (Can be set separately for acceleration and deceleration.)	
I/O Signals	Encoder Divided Pulse Output	Phase A, phase B, phase C: Line-driver output Number of divided output pulses: Any setting is allowed.
	Linear Servomotor Overheat Protection Signal Input	Number of input points: 1 Input voltage range: 0 V to +5 V

Continued on next page.

Continued from previous page.

Item			Specification
I/O Signals	Sequence Input Signals	SERVO-PACKs	Fixed Input Signals
			Input Signals for Which Allocations Can Be Changed
			<p>Allowable voltage range: 5 VDC \pm5%</p> <p>Number of input points: 1</p> <p>Input signal: SEN (Absolute Data Request) signal</p> <hr/> <p>Number of input points: 1</p> <p>Input method: Line driver or open collector</p> <p>Input Signals</p> <ul style="list-style-type: none"> • /DEC (Homing Deceleration Switch) signal • /RGRT (Registration Input) signal • CLR (Clear) signal <hr/> <p>Allowable voltage range: 24 VDC \pm20%</p> <p>Number of input points: 7</p> <p>Input method: Sink inputs or source inputs</p> <p>Input Signals</p> <ul style="list-style-type: none"> • /S-ON (Servo ON) signal • /P-CON (Proportional Control) Signal • P-OT (Forward Drive Prohibit) and N-OT (Reverse Drive Prohibit) signals • /ALM-RST (Alarm Reset) signal • /P-CL (Forward External Torque Limit) and /N-CL (Reverse External Torque Limit) signals • /SPD-D (Motor Direction) signal • /SPD-A and /SPD-B (Internal Set Speed Selection) signals • /C-SEL (Control Selection) signal • /ZCLAMP (Zero Clamping) signal • /INHIBIT (Reference Pulse Inhibit) signal • /P-DET (Polarity Detection) signal • /G-SEL (Gain Selection) signal • /PSEL (Reference Pulse Input Multiplication Switch) Signal • SEN (Absolute Data Request) signal • /DEC (Homing Deceleration Switch) signal • /MODE 0/1 (Mode Switch Input) signal • /START-STOP (Program Table Operation Start-Stop Input) signal • /JOGP (Forward Jog Input) signal • /JOGN (Reverse Jog Input) signal • /HOME (Homing Input) signal • /PGMRES (Program Table Operation Reset Input) signal • /SEL0 (Program Step Selection Input 0) signal • /SEL1 (Program Step Selection Input 1) signal • /SEL2 (Program Step Selection Input 2) signal • /SEL3 (Program Step Selection Input 3) signal • /SEL4 (Program Step Selection Input 4) signal • /JOG0 (Jog Speed Table Selection Input 0) signal • /JOG1 (Jog Speed Table Selection Input 1) signal • /JOG2 (Jog Speed Table Selection Input 2) signal <p>A signal can be allocated and the positive and negative logic can be changed.</p>

Continued on next page.

Continued from previous page.

Item			Specification	
I/O Signals	Sequence Output Signals	SERVO-PACKs	Fixed Output	Allowable voltage range: 5 VDC to 30 VDC Number of output points: 1 Output signal: ALM (Servo Alarm) signal
			Output Signals That Can Be Allocated	Allowable voltage range: 5 VDC to 30 VDC Number of output points: 6 (A photocoupler output (isolated) is used for three of the outputs.) (An open-collector output (non-isolated) is used for the other three outputs.) Output Signals <ul style="list-style-type: none"> • /COIN (Positioning Completion) Signal • /V-CMP (Speed Coincidence Detection) Signal • /TGON (Rotation Detection) Signal • /S-RDY (Servo Ready) signal • /CLT (Torque Limit Detection) Signal • /VLT (Speed Limit Detection) Signal • /BK (Brake) signal • /WARN (Warning) Signal • /NEAR (Near) signal • /PSELA (Reference Pulse Input Multiplication Switching Output) signal • ALO1, ALO2, and ALO3 (Alarm Code) signals • /POUT0 (Programmable Output 0) signal • /POUT1 (Programmable Output 1) signal • /POUT2 (Programmable Output 2) signal • /POUT3 (Programmable Output 3) signal • /POUT4 (Programmable Output 4) signal • /POSRDY (Homing Completed Output) signal • DEN (Position Reference Distribution Completed) signal A signal can be allocated and the positive and negative logic can be changed.
Communi-cations	RS-422A Communi-cations (CN3)	Interfaces	Digital Operator (JUSP-OP05A-1-E)	
		1:N Communications	Up to N = 15 stations possible for RS-422A port	
	USB Communi-cations (CN7)	Axis Address Setting	Set with parameters.	
		Interface	Personal computer (with SigmaWin+)	
		Communications Standard	Conforms to USB2.0 standard (12 Mbps).	
Displays/Indicators			CHARGE indicator and five-digit seven-segment display	
Panel Operator			Four push switches	
Operating Methods	Program Table		<ul style="list-style-type: none"> • Program table positioning in which steps are executed in sequence with commands from contact inputs • Positioning by specifying station numbers with commands from contact inputs 	
		Maximum Number of Steps	256 steps (Up to 32 steps can be selected with input signals.)	
	Other Functions		Registration (positioning with external signals) and homing	
Analog Monitor (CN5)			Number of points: 2 Output voltage range: ± 10 VDC (effective linearity range: ± 8 V) Resolution: 16 bits Accuracy: ± 20 mV (Typ) Maximum output current: ± 10 mA Settling time ($\pm 1\%$): 1.2 ms (Typ)	
Dynamic Brake (DB)			Activated when a servo alarm or overtravel (OT) occurs, or when the power supply to the main circuit or servo is OFF.	

Continued on next page.

Continued from previous page.

Item		Specification		
Regenerative Processing		Built-in (An external resistor must be connected to the SGD7S-470A to -780A.) Refer to the following catalog for details. ☞ Σ -7-Series AC Servo Drive Peripheral Device Selection Manual (Manual No.: SIEP S800001 32)		
Overtravel (OT) Prevention		Stopping with dynamic brake, deceleration to a stop, or coasting to a stop for the P-OT (Forward Drive Prohibit) or N-OT (Reverse Drive Prohibit) signal		
Protective Functions		Overcurrent, overvoltage, low voltage, overload, regeneration error, etc.		
Utility Functions		Gain adjustment, alarm history, jog operation, origin search, etc.		
Safety Functions	Inputs	/HWBB1 and /HWBB2: Base block signals for Power Modules		
	Output	EDM1: Monitors the status of built-in safety circuit (fixed output).		
	Applicable Standards* ³	ISO13849-1 PLe (Category 3) and IEC61508 SIL3		
Applicable Option Modules		Fully-closed Modules and Safety Modules Note: You cannot use a Fully-closed Module and a Safety Module together.		
Controls	Speed Control	Soft Start Time Setting		0 s to 10 s (Can be set separately for acceleration and deceleration.)
		Input Signal	Reference Voltage	<ul style="list-style-type: none"> • Maximum input voltage: ± 12 V (forward motor rotation for positive reference). • 6 VDC at rated speed (default setting). Input gain setting can be changed.
			Input Impedance	Approx. 14 k Ω
			Circuit Time Constant	30 μ s
	Internal Set Speed Control	Rotation Direction Selection	With Proportional Control signal	
		Speed Selection	With Forward/Reverse External Torque Limit signals (speed 1 to 3 selection). Servomotor stops or another control method is used when both signals are OFF.	

Continued on next page.

Continued from previous page.

Item		Specification			
Controls	Position Control	Feedforward Compensation		0% to 100%	
		Output Signal Positioning Completed Width Setting		0 to 1,073,741,824 reference units	
		Input Signals	Reference pulses	Reference Pulse Form	One of the following is selected: Sign + pulse train, CW + CCW pulse trains, and two-phase pulse trains with 90° phase differential
				Input Form	Line driver or open collector
				Maximum Input Frequency	<ul style="list-style-type: none"> Line Driver Sign + pulse train or CW + CCW pulse trains: 4 Mpps Two-phase pulse trains with 90° phase differential: 1 Mpps Open Collector Sign + pulse train or CW + CCW pulse trains: 200 kpps Two-phase pulse trains with 90° phase differential: 200 kpps
				Input Multiplication Switching	1 to 100 times
		Clear Signal		Position deviation clear Line driver or open collector	
	Torque Control	Input Signal	Reference Voltage	<ul style="list-style-type: none"> Maximum input voltage: ±12 V (forward torque output for positive reference). 3 VDC at rated torque (default setting). Input gain setting can be changed. 	
			Input Impedance	Approx. 14 kΩ	
			Circuit Time Constant	16 μs	

*1. If you combine a Σ-7-Series SERVOPACK with a Σ-V-Series Option Module, the following Σ-V-Series SERVO-PACKs specifications must be used: a surrounding air temperature of 0°C to 55°C and an altitude of 1,000 m max. Also, the applicable surrounding range cannot be increased by derating.

*2. The coefficient of speed fluctuation for load fluctuation is defined as follows:

$$\text{Coefficient of speed fluctuation} = \frac{\text{No-load motor speed} - \text{Total-load motor speed}}{\text{Rated motor speed}} \times 100\%$$

*3. Always perform risk assessment for the system and confirm that the safety requirements are met.

Wiring and Connecting SERVOPACKs

3



This chapter provides information on wiring and connecting SERVOPACKs to power supplies and peripheral devices.

3.1	Basic Wiring Diagrams	3-2
3.2	I/O Signal Connections	3-4
3.2.1	I/O Signal Connector (CN1) Names and Functions	3-4
3.2.2	I/O Signal Connector (CN1) Pin Arrangement . . .	3-7

3.1 Basic Wiring Diagrams

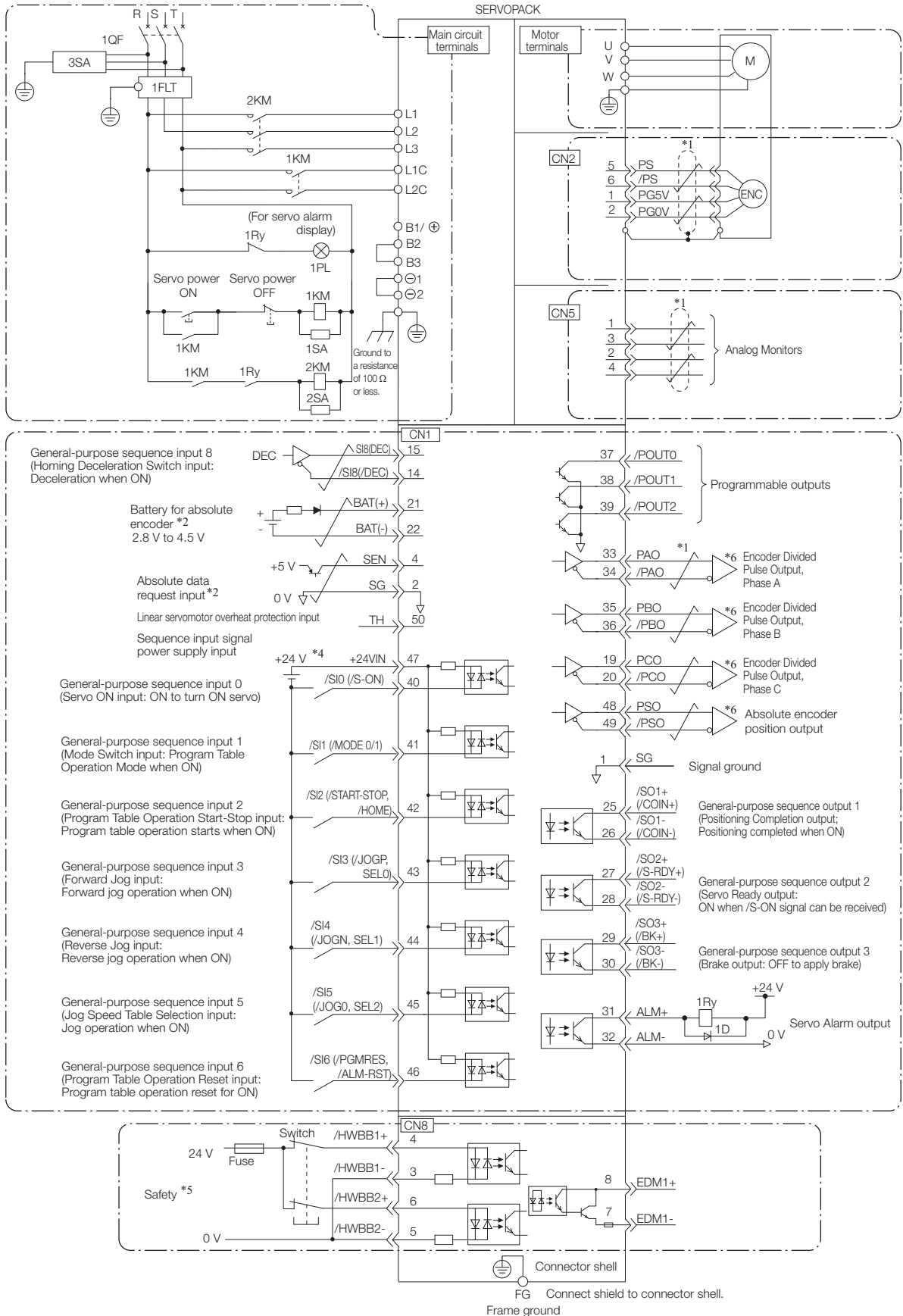
This section provide the basic wiring diagrams. Refer to the reference sections given in the diagrams for details.



- *1.  represents twisted-pair wires.
 - *2. Connect these when using an absolute encoder. If the Encoder Cable with a Battery Case is connected, do not connect a backup battery.
 - *3. You can enable this function with a parameter setting.
 - *4. The 24-VDC power supply is not provided by Yaskawa. Use a 24-VDC power supply with double insulation or reinforced insulation.
 - *5. Refer to the following manual if you use a safety function device.
 Σ -7-Series Σ -7S SERVOPACK with Analog Voltage/Pulse Train References Product Manual (Manual No.: SIEP S800001 26)
- If you do not use the safety function, insert the Safety Jumper Connector (provided as an accessory) into CN8 when you use the SERVOPACK.
- *6. Always use line receivers to receive the output signals.
- Note: 1. If you use a 24-V brake, install a separate power supply for the 24-VDC power supply from other power supplies, such as the one for the I/O signals of the CN1 connector. If the power supply is shared, the I/O signals may malfunction.
2. Default settings are given in parentheses.

3.2 I/O Signal Connections

3.2.1 I/O Signal Connector (CN1) Names and Functions

The following table gives the pin numbers, names, and functions of the I/O signal pins for the default settings.

Input Signals

Default settings are given in parentheses.

Control Method	Signal	Pin No.	Name	Function	Reference Page
Any Control Method	/SI0* (/S-ON)	40	General-purpose Sequence Input 0 (Servo ON Input)	You can allocate the input signal to use with a parameter. Controls turning the Servomotor ON and OFF (supplying/not supplying power).	page 6-3
	/SI3* (MODE 0/ 1)	41	General-purpose Sequence Input 1 (Mode Switch Input)	You can allocate the input signal to use with a parameter. Switches between mode 0 and mode 1. ON: Program Table Operation Mode is entered (mode 0). OFF: Jog Speed Table Operation or Homing Mode is entered (mode 1).	page 6-3
	/SI1* (/START-STOP, /HOME)	42	General-purpose Sequence Input 2 (Program Table Operation Start-Stop Input or Homing Input)	You can allocate the input signal to use with a parameter. Mode 0: When the signal turns ON, program table operation starts or restarts. Refer to /SEL0 to /SEL4 when starting. When this signal turns OFF, the program table operation is stopped. Mode 1: When the signal turns ON, homing is started or restarted. When the signal turns OFF, homing is canceled.	page 6-3
	/SI2* (/JOGP, SEL0)	43	General-purpose Sequence Input 3 (Forward Jog Input or Program-Specified Area 1 Input)	You can allocate the input signal to use with a parameter. Mode 0: Program table selection 0 Mode 1: Forward jog operation starts when the input signal turns ON. (Jog operation stops when the signal turns OFF.)	
	/SI5* (/JOG0, /SEL2)	45	General-purpose Sequence Input 5 (Jog Speed Table Selection Input or Program-Specified Area 3 Input)	You can allocate the input signal to use with a parameter. Mode 0: Program table selection 2 Mode 1: Jog operation is started when the input signal turns ON.	
	/SI6* (/PGM-RES, /ALM-RST)	46	General-purpose Sequence Input 6 (Program Table Operation Reset Input or Alarm Clear Input)	You can allocate the input signal to use with a parameter. Mode 0: If this signal turns ON while a program table operation is stopped, the program table operation will be reset. Mode 0 or mode 1: An alarm is reset. (There are a limited number of general-purpose input signals, so this signal is used for two functions. Both /ALM-RST and /PGM-RES are used to reset errors.)	page 6-3
	/SI4* (/JOGN, SEL1)	44	General-purpose Sequence Input 4 (Reverse Jog Input or Program-Specified Area 2 Input)	You can allocate the input signal to use with a parameter. Mode 0: Program table selection 1 Mode 1: Reverse jog operation is performed. (Jog operation stops when the signal turns OFF.)	page 6-3

Continued on next page.

Continued from previous page.

Control Method	Signal	Pin No.	Name	Function	Reference Page
Any Control Method	+24VIN	47	Sequence Input Signal Power Supply Input	Inputs the sequence input signal power supply. Allowable voltage range: 24 VDC \pm 20% The 24-VDC power supply is not provided by Yaskawa.	–
	SEN	4 (2)	Absolute Data Request Input (SEN)	Inputs the position data request signal for an absolute encoder.	–
	BAT+	21	Battery for absolute encoder (+)	These are the pins to connect the absolute encoder backup battery. Do not connect these pins if you use the Encoder Cable with a Battery Case.	–
	BAT-	22	Battery for absolute encoder (-)		–
	TH	50	Linear Servomotor Overheat Protection Input	Inputs the overheat protection signal from a Linear Servomotor.	–
Speed Control	V-REF	5 (6)	Speed Reference Input	Inputs the speed reference. Maximum input voltage: \pm 12 V	–
Position Control	PULS /PULS	7 8	Pulse Reference Input	One of the following input pulse forms is set. • Sign + pulse train • CW + CCW pulse trains • 90° phase-differential pulses	–
	SIGN /SIGN	11 12	Sign of Reference Input		–
	SI8(DEC) /SI8(/DEC)	15 14	General-purpose Sequence Input 8 (Homing Deceleration Switch Input)	You can allocate the input signal to use with a parameter. The homing speed is changed to the approach speed or creep speed.	page 6-5
Torque Control	T-REF	9 (10)	Torque Reference Input	Inputs the torque reference. Maximum input voltage: \pm 12 V	–

* You can change the allocations. Refer to the following section for details.

 6.2.1 Input Signal Allocations on page 6-3

Note: 1. Pin numbers in parentheses () indicate signal grounds.

2. If forward drive prohibition or reverse drive prohibition is used, the SERVOPACK is stopped by software controls. If the application does not satisfy the safety requirements, add external safety circuits as required.

Output Signals

Default settings are given in parentheses.

Control Method	Signal	Pin No.	Name	Function	Reference Page	
Any Control Method	ALM+	31	Servo Alarm Output	Turns OFF (opens) when an error is detected.	-	
	ALM-	32				
	/SO2+* (/S-RDY+)	27	General-purpose Sequence Output 2 (Servo Ready Output)	You can allocate the output signal to use with a parameter. Turns ON (closes) when the SERVO-PACK is ready to acknowledge the /S-ON (Servo ON) signal.	page 6-5	
	/SO2-* (/S-RDY-)	28				
	/SO3+* (/BK)	29	General-purpose Sequence Output 3 (Brake Output)	You can allocate the output signal to use with a parameter. Activates the brake.	page 6-5	
	/SO3-* (/BK)	30				
	PAO	33	Encoder Divided Pulse Output, Phase A	Output the encoder divided pulse output signals with a 90° phase differential.	-	
	/PAO	34				
	PBO	35	Encoder Divided Pulse Output, Phase B		-	
	/PBO	36				
	PCO	19	Encoder Divided Pulse Output, Phase C	Outputs the origin signal once every encoder rotation.	-	
	/PCO	20				
	PSO	48	Absolute Encoder Position Output	Outputs the position data of the absolute encoder.	-	
	/PSO	49				
		ALO1* (/POUT0)	37 (1)	Programmable Outputs	You can allocate the output signals to use with parameters. Output the programmed signals.	page 6-5
		ALO2* (/POUT1)	38 (1)			
	ALO3* (/POUT2)	39 (1)				
	FG	Shell	Frame ground	Connected to the frame ground if the shield of the I/O Signal Cable is connected to the connector shell.	-	
Position Control	/SO1+* (/COIN+)	25	General-purpose Sequence Output 1 (Positioning Completion Output)	You can allocate the output signals to use with parameters. Turns ON (closes) if the position deviation reaches the set value when position control is selected.	page 6-5	
	/SO1-* (/COIN-)	26				
	PL1	3	Open-Collector Power Supply Output for Reference Pulses	Outputs the open-collector power supply for reference pulses.	-	
	PL2	13				
PL3	18					
-	-	16 17 23 24 48 49 50	-	Do not use these terminals.	-	

* You can change the allocations. Refer to the following section for details.

 6.2.2 Output Signal Allocations on page 6-5

Note: Pin numbers in parentheses () indicate signal grounds.

3.2.2 I/O Signal Connector (CN1) Pin Arrangement

The following figure gives the pin arrangement of the of the I/O signal connector (CN1) for the default settings.

2	SG	Signal Ground	1	SG	Signal Ground	27	/SO2+ (/S-RDY+)	General-purpose Sequence Output 2	26	/SO1- (/COIN-)	General-purpose Sequence Output 1
4	SEN	Absolute Data Request Input (SEN)	3	PL1	Open-Collector Power Supply Output for Reference Pulses	29	/SO3+ (/BK+)	General-purpose Sequence Output 3	28	/SO2- (/S-RDY-)	General-purpose Sequence Output 2
6	SG	Signal Ground	5	V-REF	Speed Reference Input	31	ALM+	Servo Alarm Output	30	/SO3- (/BK-)	General-purpose Sequence Output 3
8	/PULS	Pulse Reference Input	7	PULS	Pulse Reference Input	33	PAO	Encoder Divided Pulse Output, Phase A	32	ALM-	Servo Alarm Output
10	SG	Signal Ground	9	T-REF	Torque Reference Input	35	PBO	Encoder Divided Pulse Output, Phase B	34	/PAO	Encoder Divided Pulse Output, Phase A
12	/SIGN	Sign of Reference Input	11	SIGN	Sign of Reference Input	37	/POUT0	Programmable Output	36	/PBO	Encoder Divided Pulse Output, Phase B
14	/SI8 (/DEC)	General-purpose Sequence Input 8	13	PL2	Open-Collector Power Supply Output for Reference Pulses	39	/POUT2	Programmable Output	38	/POUT1	Programmable Output
16	-	-	15	SI8 (DEC)	General-purpose Sequence Input 8	41	/SI1 (MODE0/1)	General-purpose Sequence Input 1	40	/SI0 (/S-ON)	General-purpose Sequence Input 0
18	PL3	Open-Collector Power Supply Output for Reference Pulses	17	-	-	43	/SI3 (/JOGP)	General-purpose Sequence Input 3	42	/SI2 (/START-STOP)	General-purpose Sequence Input 2
20	/PCO	Encoder Divided Pulse Output, Phase C	19	PCO	Encoder Divided Pulse Output, Phase C	45	/SI5 (/JOG0)	General-purpose Sequence Input 5	44	/SI4 (/JONGN)	General-purpose Sequence Input 4
22	BAT-	Battery for Absolute Encoder (-)	21	BAT+	Battery for Absolute Encoder (+)	47	+24VIN	Sequence Input Signal Power Supply Input	46	/SI6 (/PGM-RES)	General-purpose Sequence Input 6
24	-	-	23	-	-	49	/PSO	Absolute Encoder Position Output	48	PSO	Absolute Encoder Position Output
			25	/SO1+ (/COIN+)	General-purpose Sequence Output 1				50	TH	Linear Servomotor Overheat Protection Input

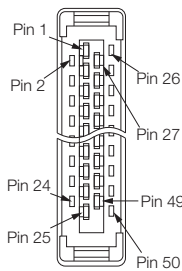

The above view is from the direction of the following arrow without the connector shell attached.

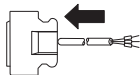

Trial Operation



This chapter gives the flow and operating procedures for trial operation.

4.1	Trial Operation Example	4-2
------------	--------------------------------------	------------

4.1 Trial Operation Example

A trial operation example for digital I/O is given below.

Refer to the following chapter for information on operation with digital I/O.

 Chapter 7 Operation with Digital I/O

1. Confirm that the wiring is correct, and then connect the I/O signal connector (CN1 connector).

Refer to the following chapter for details on wiring.

 Chapter 3 Wiring and Connecting SERVOPACKs

2. Turn ON the power supplies to the SERVOPACK.
If power is being supplied correctly, the CHARGE indicator on the SERVOPACK will light.

3. Set the following items, which are necessary for trial operation.
Program Table Operation



Setting	Reference
Electronic Gear	 Σ -7-Series Σ -7S SERVOPACK with Analog Voltage/Pulse Train References Product Manual (Manual No.: SIEP S800001 26)
Motor Direction	
Overtravel	

4. Input the /S-ON (Servo ON) signal.
The servo will turn ON.

5. Operate the Servomotor at low speed.
Program Table Operation

PGM-STEP	POS	SPD	RDST	RSPD	ACC	DEC	POUT	EVENT	LOOP	NEXT
0	I+10000	1000	-	1000	:	:	IT0	1	END

6. While operation is in progress for step 5, confirm the following items.

Confirmation Item	Reference
Confirm that the rotational direction of the Servomotor agrees with the forward or reverse reference. If they do not agree, correct the rotation direction of the Servomotor.	 Σ -7-Series Σ -7S SERVOPACK with Analog Voltage/Pulse Train References Product Manual (Manual No.: SIEP S800001 26)
Confirm that no abnormal vibration, noise, or temperature rise occurs. If any abnormalities are found, implement corrections.	 8.3 Troubleshooting Based on the Operation and Conditions of the Servomotor on page 8-49

Note: If the load machine is not sufficiently broken in before trial operation, the Servomotor may become overloaded.

Monitoring



This chapter provides information on monitoring SERVO-
PACK product information and SERVOPACK status.

5.1	Monitoring SERVOPACK Status	5-2
5.1.1	Monitoring Status and Operations	5-2
5.1.2	I/O Signal Monitor	5-4
5.2	Monitoring Machine Operation Status and Signal Waveforms . .	5-5

5.1 Monitoring SERVOPACK Status

5.1.1 Monitoring Status and Operations

Use the following procedure to display the SERVOPACK Operation Monitor and Status Monitor Windows.

- Select **Monitor** in the Menu Dialog Box.

If these check boxes are selected, the current values are displayed in the *Value* column.

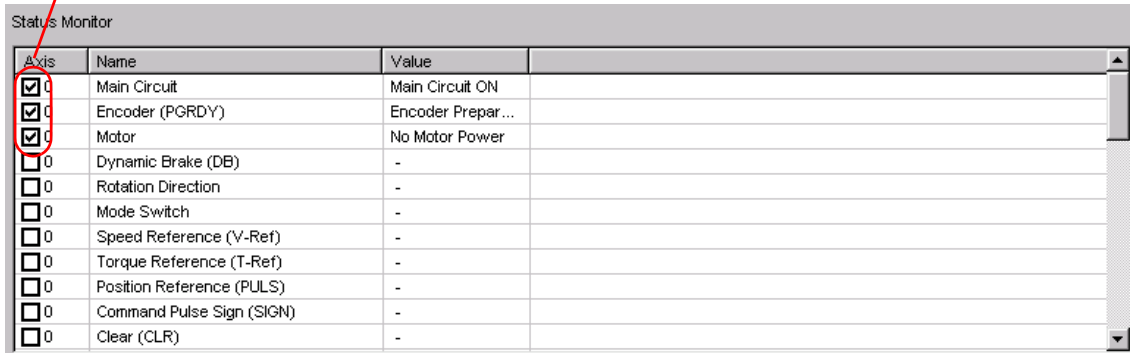

Axis	Name	Value
<input checked="" type="checkbox"/>	Main Circuit	Main Circuit ON
<input checked="" type="checkbox"/>	Encoder (PGRDY)	Encoder Prepar...
<input checked="" type="checkbox"/>	Motor	No Motor Power
<input type="checkbox"/>	Dynamic Brake (DB)	-
<input type="checkbox"/>	Rotation Direction	-
<input type="checkbox"/>	Mode Switch	-
<input type="checkbox"/>	Speed Reference (V-Ref)	-
<input type="checkbox"/>	Torque Reference (T-Ref)	-
<input type="checkbox"/>	Position Reference (PULS)	-
<input type="checkbox"/>	Command Pulse Sign (SIGN)	-
<input type="checkbox"/>	Clear (CLR)	-

Monitor Items

The items that you can monitor on the Status Monitor Window and Motion Monitor Window are listed below.

• Status Monitor Window

Monitor Items					
Internal Status	<ul style="list-style-type: none"> • Main Circuit • Encoder (PGRDY) • Motor Power (Request) • Motor Power ON • Dynamic Brake (DB) • Rotation (Movement) Direction • Mode Switch • Speed Reference (V-Ref) • Torque Reference (T-Ref) • Position Reference (PULS) • Position Reference Direction • Surge Current Limiting Resistor Short Relay • Regenerative Transistor • Regenerative Error Detection • AC Power ON • Overcurrent • Origin Not Passed • NEAR Status • DEN Status • Positioning Stopped or Program Stopped • Program Operating Status • Current Limit Status • Main Power Supply Status 	Input Signal Status	<ul style="list-style-type: none"> • /S-ON (Servo ON Input Signal) • P-OT (Forward Drive Prohibit Input Signal) • N-OT (Reverse Drive Prohibit Input Signal) • /ALM-RST (Alarm Reset Input Signal) • Clear Signal (CLR) • /DEC (Homing Deceleration Switch Input Signal) • /RGRT (Registration Input Signal) • /MODE 0/1 (Mode Switch Input Signal) • /START-STOP (Program Table Operation Start-Stop Input Signal) • /PGMRES (Program Table Operation Reset Input Signal) • /SEL0 (Program Step Selection Input 0 Signal) • /SEL1 (Program Step Selection Input 1 Signal) • /SEL2 (Program Step Selection Input 2 Signal) • /SEL3 (Program Step Selection Input 3 Signal) • /SEL4 (Program Step Selection Input 4 Signal) • /HOME (Homing Input Signal) • /JOGP (Forward Jog Input Signal) • /JOGN (Reverse Jog Input Signal) • /JOG0 (Jog Speed Table Selection Input 0 Signal) • /JOG1 (Jog Speed Table Selection Input 1 Signal) • /JOG2 (Jog Speed Table Selection Input 2 Signal) 	Output Signal Status	<ul style="list-style-type: none"> • ALM (Servo Alarm Output Signal) • /S-RDY (Servo Ready Output Signal) • /BK (Brake Output Signal) • /WARN (Warning Output Signal) • PAO (Encoder Divided Pulse Output Phase A Signal) • PBO (Encoder Divided Pulse Output Phase B Signal) • PCO (Encoder Divided Pulse Output Phase C Signal) • ALO1, ALO2, and ALO3 (Alarm Code Output Signals) • /COIN (Positioning Completion Output Signal) • /POUT0 (Programmable Output 0 Signal) • /POUT1 (Programmable Output 1 Signal) • /POUT2 (Programmable Output 2 Signal) • /POUT3 (Programmable Output 3 Signal) • /POUT4 (Programmable Output 4 Signal) • /POSRDY (Homing Completed Output Signal) • DEN (Position Reference Distribution Completed Signal)

• Motion Monitor Window

Monitor Items	
<ul style="list-style-type: none"> • Current Alarm State • Error Monitor • Position Reference Current Position • Motor Current Position • Positioning Target Position • Positioning Distance • Registration Target Position • Registration Distance • Program Step • Elapsed Event Time • Loop Execution Elapsed Time • Motor Speed • Speed Reference • Internal Torque Reference • Angle of Rotation 1 (number of encoder pulses from origin within one encoder rotation) • Angle of Rotation 2 (angle from origin within one encoder rotation) 	<ul style="list-style-type: none"> • Input Reference Pulse Speed • Deviation Counter (Position Deviation) • Cumulative Load • Regenerative Load • Power Consumption • Consumed Power • Cumulative Power Consumption • DB Resistor Consumption Power • Absolute Encoder Multiturn Data • Absolute Encoder Position within One Rotation • Absolute Encoder (Lower) • Absolute Encoder (Upper) • Reference Pulse Counter • Feedback Pulse Counter • Fully Closed Feedback Pulse Counter • Total Operating Time

5.1.2 I/O Signal Monitor

Use the following procedure to check I/O signals.

1. Select the Servo Drive's  Button from the workspace of the Main Window of the SigmaWin+.
2. Select **Wiring Check** in the Menu Dialog Box. The Wiring Check Dialog Box will be displayed.
3. Click the **Monitor Mode** Button.

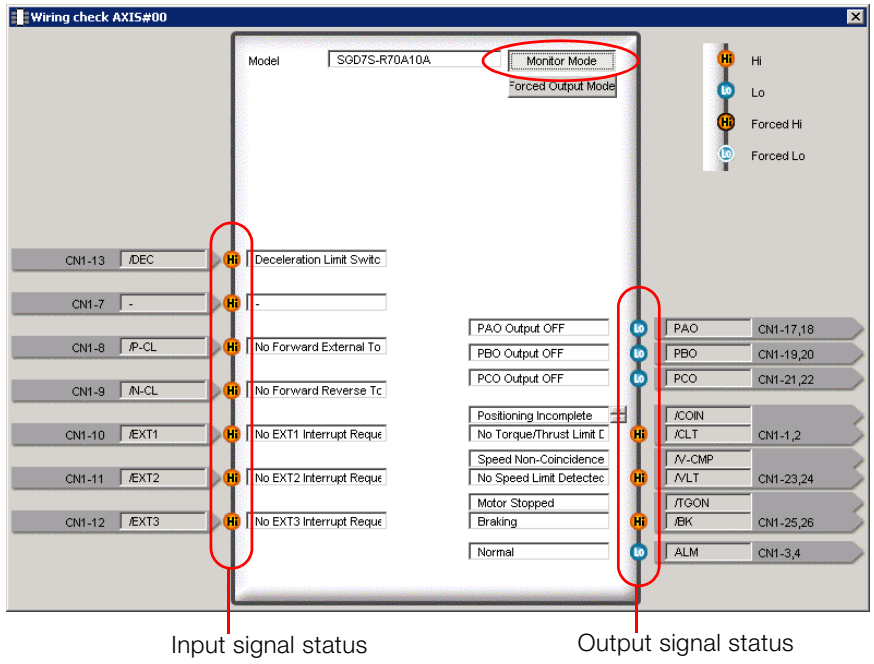

Information

- You can also use the above window to check wiring.
- **Checking Input Signal Wiring**
Change the signal status at the host controller. If the input signal status on the window changes accordingly, then the wiring is correct.
 - **Checking Output Signal Wiring**
Click the **Force Output Mode** Button. This will force the output signal status to change. If the signal status at the host controller changes accordingly, then the wiring is correct. You cannot use the **Force Output Mode** Button while the servo is ON.

5.2

Monitoring Machine Operation Status and Signal Waveforms

To monitor waveforms, use the SigmaWin+ trace function or a measuring instrument, such as a memory recorder.

This section describes how to trace data and I/O with the SigmaWin+.

Refer to the following manual for detailed operating procedures for the SigmaWin+.

 AC Servo Drives Engineering Tool SigmaWin+ Selection Manual (Manual No.: SIEP S800001 34)

Operating Procedure

1. Select the Servo Drive's  Button from the workspace of the Main Window of the SigmaWin+.
2. Select **Adjust the Speed and Torque Reference Offset** in the Menu Dialog Box. The Zero Point Position Setting Dialog Box will be displayed.

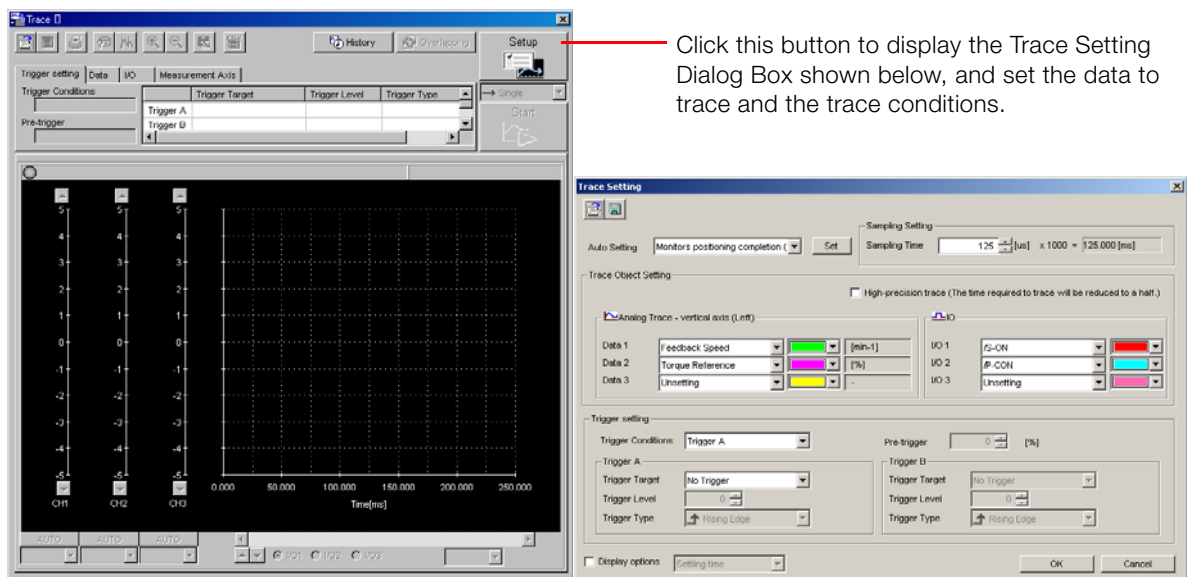

Trace Objects

You can trace the following items.

- Data Tracing

Trace Objects	
<ul style="list-style-type: none"> • Torque Reference • Feedback Speed • Reference Speed • Position Reference Speed • Position Error (Deviation) • Position Amplifier Error (Deviation) 	<ul style="list-style-type: none"> • Motor - Load Position Deviation • Speed Feedforward • Torque Feedforward • Effective (Active) Gain • Main Circuit DC Voltage • External Encoder Speed • Control Mode

• I/O Tracing

Trace Objects	
Input Signals	<ul style="list-style-type: none"> • /S-ON (Servo ON Input Signal) • /P-CON (Proportional Control Input Signal) • P-OT (Forward Drive Prohibit Input Signal) • N-OT (Reverse Drive Prohibit Input Signal) • /ALM-RST (Alarm Reset Input Signal) • /P-CL (Forward External Torque/Force Limit Input Signal) • /N-CL (Reverse External Torque/Force Limit Input Signal) • /SPD-D (Motor Direction Input Signal) • /SPD-A (Internal Set Speed Selection Input Signal) • /SPD-B (Internal Set Speed Selection Input Signal) • /C-SEL (Control Selection Input Signal) • /ZCLAMP (Zero Clamping Input Signal) • /INHIBIT (Reference Pulse Inhibit Input Signal) • /G-SEL (Gain Selection Input Signal) • /P-DET (Polarity Detection Input Signal) • FSTP (Forced Stop Input Signal) • SEN (Absolute Data Request Input Signal) • PULS (Pulse Reference Input Signal) • SIGN (Sign Reference Input Signal) • CLR (Position Deviation Clear Input Signal) • /PSEL (Reference Pulse Input Multiplication Input Signal) • /HWBB1 (Hard Wire Base Block Input 1 Signal) • /HWBB2 (Hard Wire Base Block Input 2 Signal)
	<p>Output Signals</p> <ul style="list-style-type: none"> • ALM (Servo Alarm Output Signal) • /COIN (Positioning Completion Output Signal) • /V-CMP (Speed Coincidence Detection Output Signal) • /TGON (Rotation Detection Output Signal) • /S-RDY (Servo Ready Output Signal) • /CLT (Torque Limit Detection Output Signal) • /MLT (Speed Limit Detection Output Signal) • /BK (Brake Output Signal) • /WARN (Warning Output Signal) • /NEAR (Near Output Signal) • ALO1 (Alarm Code Output Signal) • ALO2 (Alarm Code Output Signal) • ALO3 (Alarm Code Output Signal) • PAO (Encoder Divided Pulse Output Phase A Signal) • PBO (Encoder Divided Pulse Output Phase B Signal) • PCO (Encoder Divided Pulse Output Phase C Signal) • /PSELA (Reference Pulse Input Multiplication Switching Output Signal)
	<p>Internal Status</p> <ul style="list-style-type: none"> • ACON (Main Circuit ON Signal) • PDETCMP (Polarity Detection Completed Signal) • DEN (Position Reference Distribution Completed Signal)

Settings

6

This chapter describes settings that are made according to the machine.

6.1	Control Method Selection	6-2
6.2	I/O Signal Allocations	6-3
6.2.1	Input Signal Allocations	6-3
6.2.2	Output Signal Allocations	6-5
6.3	Moving Mode and Coordinate Settings	6-8
6.3.1	When the Coordinates are the Linear Type	6-8
6.3.2	When the Coordinates are the Rotary Type	6-9
6.4	Settings for References	6-10
6.4.1	Motor Speed	6-10
6.4.2	Acceleration Rate and Deceleration Rate	6-10
6.4.3	Smoothing	6-11
6.5	Origin Settings	6-12
6.5.1	When Using an Absolute Encoder	6-12
6.5.2	When Using an Incremental Encoder	6-13

6.1 Control Method Selection

To perform operation with the program table or jog speed table, set Pn000 (Control Method Selection) to n.□□1□.

Pn000 = n.□□X□	Control Method	Outline	Reference
n.□□1□ (default setting)	Position control	Commands from the program table and jog speed table are used to control machine positioning.	Chapter 7

Information Operation is also possible by combining program table operation and jog speed table operation with speed control, position control, or torque control. You can perform the optimum operation for the application.

To combine different types of control, you set the control method in Pn000 = n.□□X□ (Control Method Selection) as shown in the following table.

Pn000 = n.□□X□	Control Method	Reference
n.□□0□	Speed control (with analog voltage) and program table operation	 Σ-7-Series Σ-7S SERVOPACK with Analog Voltage/Pulse Train References Product Manual (Manual No.: SIEP S800001 26)
n.□□1□ (default setting)	Position control (with pulse train) and program table operation	
n.□□2□	Torque control (with analog voltage) and program table operation	

- Note: 1. Before you change between program table operation and another form of control, confirm that all commands and the motor have stopped.
 2. If you use program table operation, do not set Pn000 to n.□□3□ to n.□□B□.

6.2 I/O Signal Allocations

Functions are allocated to the pins on the I/O signal connector (CN1) in advance. You can change the allocations and the polarity for some of the connector pins. Function allocations and polarity settings are made with parameters.

This section describes the I/O signal allocations.

6.2.1 Input Signal Allocations

Changing Input Signal Allocations



Important

- If you change the polarity of the /S-ON (SERVO ON Input) signal from the default setting, you will not be able to turn OFF the main circuit power supply to the Servomotor if signal lines break or other problems occur. If you change the polarity of this signal, verify operation and make sure that no safety problems will exist.
- If you allocate two or more signals to the same input circuit, a logical OR of the inputs will be used and all of the allocated signals will operate accordingly. This may result in unexpected operation.

◆ Input Signals That Can Be Allocated to CN1-40 to CN1-46

The input signals that you can allocate to the pins on the I/O signal connector (CN1) and the related parameters are given in the following table.

Input Signal	Input Signal Name	Parameter
/S-ON	Servo ON	Pn50A = n.□□X□
/P-CON	Proportional Control	Pn50A = n.□X□□
P-OT	Forward Drive Prohibit	Pn50A = n.X□□□
N-OT	Reverse Drive Prohibit	Pn50B = n.□□□X
/ARM-RST	Alarm Reset	Pn50B = n.□□X□
/P-CL	Forward External Torque Limit	Pn50B = n.□X□□
/N-CL	Reverse External Torque Limit	Pn50B = n.X□□□
/SPD-D	Motor Direction	Pn50C = n.□□□X
/SPD-A	Internal Set Speed Selection	Pn50C = n.□□X□
/SPD-B	Internal Set Speed Selection	Pn50C = n.□X□□
/C-SEL	Control Selection	Pn50C = n.X□□□
/ZCLAMP	Zero Camping	Pn50D = n.□□□X
/INHIBIT	Reference Pulse Inhibit	Pn50D = n.□□X□
/G-SEL	Gain Selection	Pn50D = n.□X□□
/P-DET	Polarity Detection	Pn50D = n.X□□□
SEN	Absolute Data Request	Pn515 = n.□□□X
/PSEL	Reference Pulse Input Multiplication Switch	Pn515 = n.□□X□
FSTP	Forced Stop	Pn516 = n.□□□X
/MODE 0/1	Mode Switch	Pn630 = n.□□□X
/START-STOP	Program Table Operation Start-Stop	Pn630 = n.□□X□
/HOME	Homing	Pn630 = n.□X□□
/PGMRES	Program Table Operation Reset	Pn630 = n.X□□□
/SEL0	Program Step Selection Input 0	Pn631 = n.□□□X
/SEL1	Program Step Selection Input 1	Pn631 = n.□□X□
/SEL2	Program Step Selection Input 2	Pn631 = n.□X□□
/SEL3	Program Step Selection Input 3	Pn631 = n.X□□□

Continued on next page.

Continued from previous page.

Input Signal	Input Signal Name	Parameter
/SEL4	Program Step Selection Input 4	Pn632 = n.□□□X
/JOGP	Forward Jog Input	Pn632 = n.□□X□
/JOGN	Reverse Jog Input	Pn632 = n.□X□□
/JOG0	Jog Speed Table Selection Input 0	Pn632 = n.X□□□
/JOG1	Jog Speed Table Selection Input 1	Pn633 = n.□□□X
/JOG2	Jog Speed Table Selection Input 2	Pn633 = n.□□X□

Relationship between Parameter Settings, Allocated Pins, and Polarities

The following table shows the relationship between the input signal parameter settings, the pins on the I/O signal connector (CN1), and polarities.

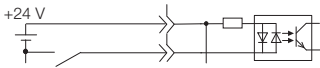
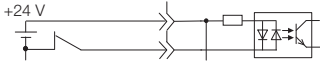
Parameter Setting	Pin No.	Description
0	40	 <p>A reverse signal (a signal with “/” before the signal abbreviation, such as the /S-ON signal) is active when the contacts are ON (closed). A signal that does not have “/” before the signal abbreviation (such as the P-OT signal) is active when the contacts are OFF (open).</p>
1	41	
2	42	
3	43	
4	44	
5	45	
6	46	
7	–	The input signal is not allocated to a connector pin and it is always active. If the signal is processed on a signal edge, then it is always inactive.
8	–	The input signal is not allocated to a connector pin and it is always inactive. Set the parameter to 8 if the signal is not used.
9	40	 <p>A reverse signal (a signal with “/” before the signal abbreviation, such as the /S-ON signal) is active when the contacts are OFF (open). A signal that does not have “/” before the signal abbreviation (such as the P-OT signal) is active when the contacts are ON (closed).</p>
A	41	
B	42	
C	43	
D	44	
E	45	
F	46	

Note: Refer to the following section for details on input signal parameter settings.

 9.2.2 List of Parameters on page 9-4

Example of Changing Input Signal Allocations

The following example shows reversing the P-OT (Forward Drive Prohibit) signal allocated to CN1-42 and the /P-CL (External Torque Limit) signal allocated to CN1-45.

Pn50A = n.2□□0	Pn50B = n.□5□□	Before change
↓	↓	
Pn50A = n.5□□1	Pn50B = n.□2□□	After change

Refer to the following manual for the parameter setting procedure.

 Σ-7-Series Σ-7S SERVOPACK with Analog Voltage/Pulse Train References Product Manual (Manual No.: SIEP S800001 26)

◆ Input Signals That Can Be Allocated to CN1-14 and CN1-15

Input Signal	Input Signal Name	Parameter Setting
CLR	Clear	Pn634 = n.□□□1
/DEC	Homing Deceleration Switch	Pn634 = n.□□□2
/RGRT	Registration	Pn634 = n.□□□3

■ Relationship between Parameter Settings, Pin Numbers, and Polarity

The polarity of the signals that you allocate to CN1-14 and CN1-15 are set in separate parameters. You can set the signal polarity in Pn634 = n.□□X□ (SI8 Signal Selection Logic).

Parameter Setting	Pin No.	Description
0	14, 15	A reverse signal (a signal with "/" before the signal abbreviation, such as the /DEC signal) is active when the contacts are ON (closed).
1		A reverse signal (a signal with "/" before the signal abbreviation, such as the /DEC signal) is active when the contacts are OFF (open).

■ Example of Changing Input Signal Allocation for CN1-14 and CN1-15

The following example shows how to change the allocation of the Return Deceleration Switch signal (/DEC) to CN1-14 and CN1-15 to allocate the Registration Input (/RGRT) instead.

Before Change: Pn634 = n.□□□2□



After Change: Pn634 = n.□□□3□

Confirming Input Signals

You can confirm the status of input signals on the I/O signal monitor. Refer to the following section for information on the I/O signal monitor.

 5.1.2 I/O Signal Monitor on page 5-4

6.2.2 Output Signal Allocations

You can allocate the desired output signals to pins 25 to 30 and 37 to 39 on the I/O signal connector (CN1). You set the allocations in the following parameters: Pn50E, Pn50F, Pn510, Pn512, Pn513, Pn514, Pn517, Pn635, and Pn636.



Important

- The signals that are not detected are considered to be OFF. For example, the /COIN (Positioning Completion) signal is considered to be OFF during speed control.
- Reversing the polarity of the /BK (Brake) signal, i.e., changing it to positive logic, will prevent the holding brake from operating if its signal line is disconnected. If you must change the polarity of this signal, verify operation and make sure that no safety problems will exist.
- If you allocate two or more signals to the same output circuit, a logical OR of the outputs will be used and all of the allocated signals will operate accordingly. This may result in unexpected operation.

Output signals are allocated as shown in the following table.

Refer to *Interpreting the Output Signal Allocation Tables* and change the allocations accordingly.

Interpreting the Output Signal Allocation Tables

These columns give the parameter settings to use. Signals are allocated to CN1 pins according to the settings.
 : Default settings.

Output Signal Name and Parameter	Output Signal	CN1 Pin No.						Disabled (Not Used)
		25 and 26	27 and 28	29 and 30	37	38	39	
Positioning Completion Pn50E = n.□□X□	/COIN	<input checked="" type="checkbox"/> 1	<input type="checkbox"/> 2	<input type="checkbox"/> 3	<input type="checkbox"/> 4	<input type="checkbox"/> 5	<input type="checkbox"/> 6	<input type="checkbox"/> 0

Output Signal Name and Parameter	Output Signal	CN1 Pin No.						Disabled (Not Used)
		25 and 26	27 and 28	29 and 30	37	38	39	
Positioning Completion Pn50E = n.□□X□	/COIN	<input checked="" type="checkbox"/> 1	<input type="checkbox"/> 2	<input type="checkbox"/> 3	<input type="checkbox"/> 4	<input type="checkbox"/> 5	<input type="checkbox"/> 6	<input type="checkbox"/> 0
Speed Coincidence Detection Pn50E = n.□X□□	/V-CMP	<input type="checkbox"/> 1	<input type="checkbox"/> 2	<input type="checkbox"/> 3	<input type="checkbox"/> 4	<input type="checkbox"/> 5	<input type="checkbox"/> 6	<input checked="" type="checkbox"/> 0
Rotation Detection Pn50E = n.□X□□	/TGON	<input type="checkbox"/> 1	<input type="checkbox"/> 2	<input type="checkbox"/> 3	<input type="checkbox"/> 4	<input type="checkbox"/> 5	<input type="checkbox"/> 6	<input checked="" type="checkbox"/> 0
Servo Ready Pn50E = n.X□□□	/S-RDY	<input type="checkbox"/> 1	<input checked="" type="checkbox"/> 2	<input type="checkbox"/> 3	<input type="checkbox"/> 4	<input type="checkbox"/> 5	<input type="checkbox"/> 6	<input type="checkbox"/> 0
Torque Limit Detection Pn50F = n.□□□X	/CLT	<input type="checkbox"/> 1	<input type="checkbox"/> 2	<input type="checkbox"/> 3	<input type="checkbox"/> 4	<input type="checkbox"/> 5	<input type="checkbox"/> 6	<input checked="" type="checkbox"/> 0
Speed Limit Detection Pn50F = n.□□X□	/VLT	<input type="checkbox"/> 1	<input type="checkbox"/> 2	<input type="checkbox"/> 3	<input type="checkbox"/> 4	<input type="checkbox"/> 5	<input type="checkbox"/> 6	<input checked="" type="checkbox"/> 0
Brake Pn50F = n.□X□□	/BK	<input type="checkbox"/> 1	<input type="checkbox"/> 2	<input checked="" type="checkbox"/> 3	<input type="checkbox"/> 4	<input type="checkbox"/> 5	<input type="checkbox"/> 6	<input type="checkbox"/> 0
Warning Pn50F = n.X□□□	/WARN	<input type="checkbox"/> 1	<input type="checkbox"/> 2	<input type="checkbox"/> 3	<input type="checkbox"/> 4	<input type="checkbox"/> 5	<input type="checkbox"/> 6	<input checked="" type="checkbox"/> 0
Near Pn510 = n.□□□X	NEAR	<input type="checkbox"/> 1	<input type="checkbox"/> 2	<input type="checkbox"/> 3	<input type="checkbox"/> 4	<input type="checkbox"/> 5	<input type="checkbox"/> 6	<input checked="" type="checkbox"/> 0
Reference Pulse Input Multiplication Switching Output Pn510 = n.□□X□	/PSELA	<input type="checkbox"/> 1	<input type="checkbox"/> 2	<input type="checkbox"/> 3	<input type="checkbox"/> 4	<input type="checkbox"/> 5	<input type="checkbox"/> 6	<input checked="" type="checkbox"/> 0
Preventative Maintenance Pn514 = n.□X□□	/PM	<input type="checkbox"/> 1	<input type="checkbox"/> 2	<input type="checkbox"/> 3	<input type="checkbox"/> 4	<input type="checkbox"/> 5	<input type="checkbox"/> 6	<input checked="" type="checkbox"/> 0
Alarm Code Pn517 = n.□□□X	ALO1	<input type="checkbox"/> 1	<input type="checkbox"/> 2	<input type="checkbox"/> 3	<input type="checkbox"/> 4	<input type="checkbox"/> 5	<input type="checkbox"/> 6	<input checked="" type="checkbox"/> 0
Alarm Code Pn517 = n.□□X□	ALO2	<input type="checkbox"/> 1	<input type="checkbox"/> 2	<input type="checkbox"/> 3	<input type="checkbox"/> 4	<input type="checkbox"/> 5	<input type="checkbox"/> 6	<input checked="" type="checkbox"/> 0
Alarm Code Pn517 = n.□X□□	ALO3	<input type="checkbox"/> 1	<input type="checkbox"/> 2	<input type="checkbox"/> 3	<input type="checkbox"/> 4	<input type="checkbox"/> 5	<input type="checkbox"/> 6	<input checked="" type="checkbox"/> 0
Programmable Output 0 Pn635 = n.□□□X	/POUT0	<input type="checkbox"/> 1	<input type="checkbox"/> 2	<input type="checkbox"/> 3	<input checked="" type="checkbox"/> 4	<input type="checkbox"/> 5	<input type="checkbox"/> 6	<input type="checkbox"/> 0
Programmable Output 1 Pn635 = n.□□X□	/POUT1	<input type="checkbox"/> 1	<input type="checkbox"/> 2	<input type="checkbox"/> 3	<input type="checkbox"/> 4	<input checked="" type="checkbox"/> 5	<input type="checkbox"/> 6	<input type="checkbox"/> 0
Programmable Output 2 Pn635 = n.□X□□	/POUT2	<input type="checkbox"/> 1	<input type="checkbox"/> 2	<input type="checkbox"/> 3	<input type="checkbox"/> 4	<input type="checkbox"/> 5	<input checked="" type="checkbox"/> 6	<input type="checkbox"/> 0
Programmable Output 3 Pn635 = n.X□□□	/POUT3	<input type="checkbox"/> 1	<input type="checkbox"/> 2	<input type="checkbox"/> 3	<input type="checkbox"/> 4	<input type="checkbox"/> 5	<input type="checkbox"/> 6	<input checked="" type="checkbox"/> 0
Programmable Output 4 Pn636 = n.□□□X	/POUT4	<input type="checkbox"/> 1	<input type="checkbox"/> 2	<input type="checkbox"/> 3	<input type="checkbox"/> 4	<input type="checkbox"/> 5	<input type="checkbox"/> 6	<input checked="" type="checkbox"/> 0
Homing Completion Output Pn636 = n.□□X□	/POSRDY	<input type="checkbox"/> 1	<input type="checkbox"/> 2	<input type="checkbox"/> 3	<input type="checkbox"/> 4	<input type="checkbox"/> 5	<input type="checkbox"/> 6	<input checked="" type="checkbox"/> 0

Continued on next page.

6.3 Moving Mode and Coordinate Settings

Use the following parameters to set the moving mode and the coordinates.

Parameter	Meaning			When Enabled	Classification	
Pn637= n.□□□X	0 [default setting]	Sets coordinates to linear type.			After restart	Setup
	1	Sets coordinates to rotary type. Moving mode is set as shortest path.				
	2	Sets coordinates to rotary type. Moving mode is always set as forward.				
	3	Sets coordinates to rotary type. Moving mode is always set as reverse.				
Pn638	Linear Type (Pn637 = n.□□□0): Forward Software Limit (P-LS) Rotary Type (Pn637 ≠ n.□□□0): End Point of Rotational Coordinates					
	Setting Range	Setting Unit	Default Setting	When Enabled	Classification	
	-536,870,911 to +536,870,911	Reference unit	+536,870,911	After restart	Setup	
Pn63A	Linear Type (Pn637 = n.□□□0): Reverse Software Limit (N-LS) Rotary Type (Pn637 ≠ n.□□□0): Starting Point of the Rotational Coordinates					
	Setting Range	Setting Unit	Default Setting	When Enabled	Classification	
	-536,870,911 to +536,870,911	Reference unit	-536,870,911	After restart	Setup	
Pn63C	Origin (Incremental Encoder) Absolute Encoder Offset (Absolute Encoder)					
	Setting Range	Setting Unit	Default Setting	When Enabled	Classification	
	-1,073,741,823 to +1,073,741,823	Reference unit	0	After restart	Setup	

6.3.1 When the Coordinates are the Linear Type

For a ball screw or other equipment with linear coordinates, set Pn637 to n.□□□0 (Moving Mode), set the forward software limit (P-LS) in Pn638, and set the reverse software limit (N-LS) in Pn63A.

One of the following errors will occur if the positioning target point exceeds a software limit: Moving Disabled Error due to P-LS (E4DE) or Moving Disabled Error due to N-LS (E4EE).

One of the following errors will also occur if ±INFINITE is specified for the target position (POS) in the program table: Moving Disabled Error due to P-LS (E4DE) or Moving Disabled Error due to N-LS (E4EE).

If the motor reaches a software limit during jog speed table operation, the motor will be stopped at the deceleration rate set in Pn640.

If you set both Pn638 and Pn63A to 0, the software limits are disabled.

The software limits are enabled when homing is completed.



6.3.2 When the Coordinates are the Rotary Type

For a rotary table or other equipment with rotational coordinates, set Pn637 = n.□□□X to 1 (shortest path), 2 (always forward), or 3 (always reverse). Set the last rotational coordinate in Pn638 (End Point of Rotational Coordinates) and the first rotational coordinate in Pn63A (Starting Point of Rotational Coordinates). Set Pn638 and Pn63A so that the origin is between them.

The software limit function will be disabled.

If Pn637 = n.□□□1 (shortest path), the motor will rotate in the shortest direction (forward or reverse) when the target position is specified as an absolute position.

If Pn637 = n.□□□2 (forward), the motor will always rotate in the forward direction when the target position is specified as an absolute position.

If Pn637 = n.□□□3 (reverse), the motor will always rotate in the reverse direction when the target position is specified as an absolute position.

If the target position is specified as an relative position, the motor will rotate in the specified direction.

Example • Pn638 = +3599, Pn63A = 0

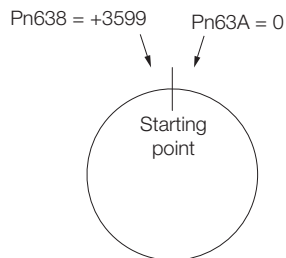

• Pn638 = +4999, Pn63A = -5000

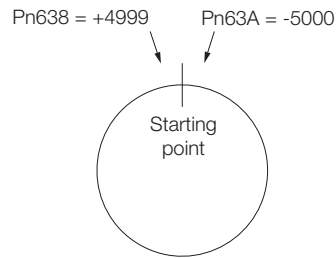

If a rotary table or other device with rotational coordinates is used, but multiturn operation is not possible, use linear coordinates (Pn637 = n.□□□0). In this case, Pn638 and Pn63A are for software limits.



When using rotary type coordinates and an absolute encoder, set the multi-turn limit (Pn205). Refer to the following manual for information on the multiturn limit settings.

Σ-7-Series Σ-7S SERVOPACK with Analog Voltage/Pulse Train References Product Manual (Manual No.: SIEP S800001 26)

6.4 Settings for References

6.4.1 Motor Speed

For program table operation, the positioning speed is registered in SPD and the registration speed is registered in RSPD. For jog speed table operation, the jog speed is registered in JSPD.

The speed is set in units of 1,000 reference units/min.

Example The following calculation applies if the reference unit is 0.01 mm and the positioning speed is 15 m/min.

$$\frac{15,000 \text{ mm/min}}{0.01 \text{ mm}} = 1,500,000 \text{ reference units/min}$$

Thus, the positioning speed setting is 1,500 [1,000 reference units/min].

6.4.2 Acceleration Rate and Deceleration Rate

For program table operation, the acceleration rate is set in ACC and the deceleration rate is set in DEC.

For jog speed table operation, the settings of the following Pn63E parameter (Acceleration Rate) and Pn640 parameter (Deceleration Rate) are used.

The acceleration and deceleration rates are set in units of 1,000 reference units/min/ms.

Pn63E	Acceleration Rate				
	Setting Range	Setting Unit	Default Setting	When Enabled	Classification
	1 to 199,999,999	1,000 (reference units/min)/ms	1,000	Immediately	Setup
Pn640	Deceleration Rate				
	Setting Range	Setting Unit	Default Setting	When Enabled	Classification
	1 to 199,999,999	1,000 (reference units/min)/ms	1,000	Immediately	Setup

Example The following calculation applies if the reference unit is 0.01 mm and the acceleration time from 0 m/min to 15 m/min is 100 ms.

$$\frac{15,000 \text{ mm/min}}{0.01 \text{ mm}} = 1,500,000 \text{ reference units/min}$$

$$\frac{1,500,000 \text{ reference units/min}}{100 \text{ ms}} = 15,000 \text{ [(reference units/min)/ms]}$$

Thus, the acceleration setting is 15 [1,000 reference units/min].



Important

Set the acceleration and deceleration so that the values of the two settings do not differ greatly. If they differ greatly, the machine will not accelerate in accordance with the settings. For example, if Pn63E is set to 199,999,999 and Pn640 is set to 1, then the machine's performance will be unpredictable.

6.4.3 Smoothing

Smoothing allows you to apply a filter to the position reference to produce smoother Servomotor acceleration and deceleration.

Note: Smoothing does not affect the travel distance.

The following parameters are related to smoothing.

Pn217	Average Position Reference Movement Time				
	Setting Range	Setting Unit	Default Setting	When Enabled	Classification
	0 to 10,000	0.1 ms	0*	Immediately after the motor stops	Setup

* The filter is disabled if you set the parameter to 0.

Note: Change the setting only when the motor is stopped.

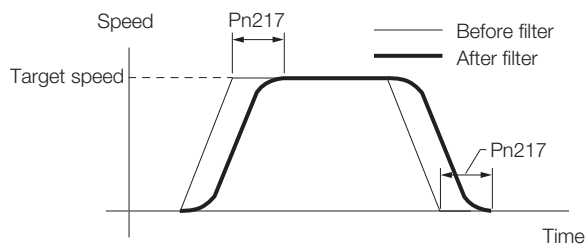

6.5 Origin Settings

It is necessary to define a reference position to operate a device or machine. This is done with origin settings.

The origin settings depend on whether an absolute encoder or an incremental encoder is used.

6.5.1 When Using an Absolute Encoder

If you use an absolute encoder, it is not necessary to set the origin every time the power supply to the equipment is turned ON.

However, when you set up the equipment, you must set Pn63C to the offset between the origin of the absolute encoder and the position of the origin of the reference coordinate system (called the machine coordinate system).

When you start a system that uses an absolute encoder, you must initialize the absolute encoder and adjust the position of the machine origin. Then you must set the offset that defines the origin of the reference coordinates.

Pn63C	Origin (Incremental Encoder) Absolute Encoder Offset (Absolute Encoder)				
	Setting Range	Setting Unit	Default Setting	When Enabled	Classification
	-1073741823 to +1073741823	Reference unit	0	After restart	Setup

Perform one of the following operations to set the offset.

- Execute utility function Fn066.
- Calculate the value and set it in Pn63C.

The relationship between the origin of the absolute encoder and the machine origin coordinate system is shown in the following figure. Use the following formula to find a new absolute encoder offset (Pn63C).

$$Pn63C = \text{Current Pn63C} + N - P$$

N: Current position of machine in new reference coordinate system

If this position is to be defined as the origin, then normally N is 0.

P: Current position of machine in current reference coordinate system

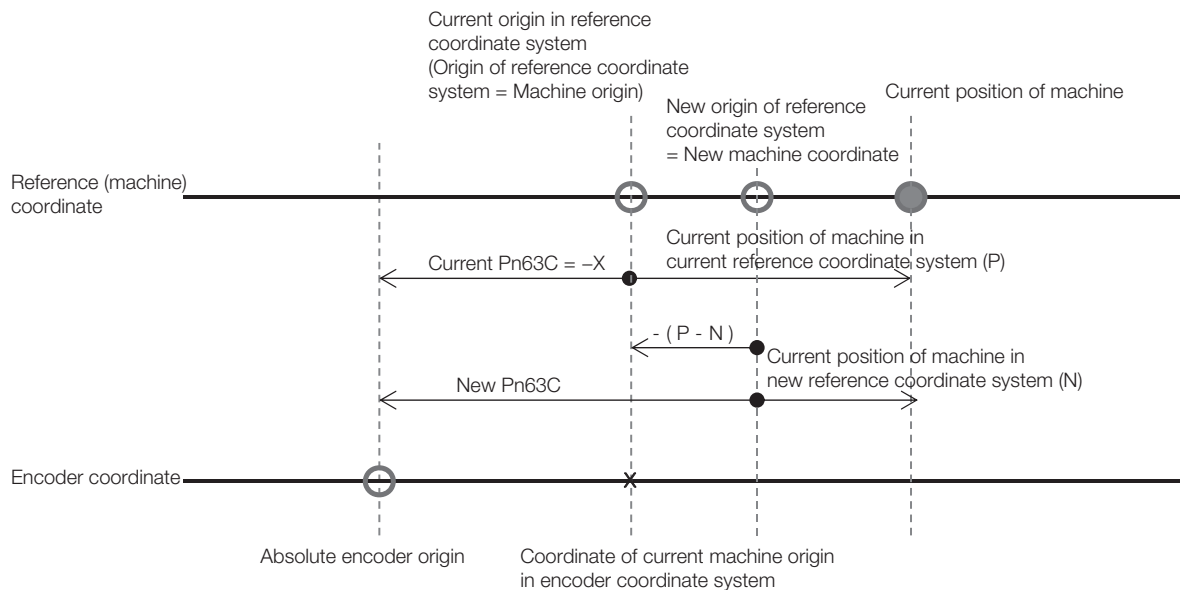

When using the linear type coordinate (Pn637 = n.□□□0), set the calculated value in Pn63C.

When using a rotary type coordinate (Pn637 ≠ n.□□□0), set the results in Pn63C after performing the following calculations so that the following relationships are satisfied: Pn63A ≤ Pn63C ≤

Pn638.

- If the results is smaller than Pn63A (the starting point of the rotational coordinates), add the width of the coordinates (Pn638 – Pn63A + 1).
- If the results is larger than Pn638 (the end point of the rotational coordinates), subtract the width of the coordinates (Pn638 – Pn63A + 1).

Refer to the following manual for information on setting up an absolute encoder.

 Σ -7-Series Σ -7S SERVOPACK with Analog Voltage/Pulse Train References Product Manual
(Manual No.: SIEP S800001 26)



You must define the origin again if you change the settings of any of the following parameters: Pn20E, Pn210, Pn205, Pn637, or Pn63C. Always turn the power supply OFF and ON again before you set the origin to enable changes to these parameters.

6.5.2 When Using an Incremental Encoder

If you use an incremental encoder, you must set the origin every time the power supply to the equipment is turned ON.

Homing is used to define the machine origin. Refer to the following section for details on homing.

 7.2 Homing on page 7-4

The setting of Pn63C is set as the current value when the power supply is turned ON or when homing is completed.

Pn63C	Origin (Incremental Encoder) Absolute Encoder Offset (Absolute Encoder)				
	Setting Range	Setting Unit	Default Setting	When Enabled	Classification
	-1073741823 to +1073741823	Reference unit	0	After restart	Setup



WARNING

- If you are using an incremental encoder, always perform homing before you start program table operation. If you perform program table operation without performing homing, positions cannot be managed so correct positioning may not be possible. Unexpected machine operation, failure, or personal injury may occur.

Operation with Digital I/O



This chapter provides detailed information on homing, positioning with a program table, registration, constant speed operation with a jog speed table, and ZONE outputs.

7.1	Operation Functions	7-3
7.2	Homing	7-4
7.2.1	I/O Signals Related to Homing	7-4
7.2.2	Parameters Related to Homing	7-5
7.2.3	Homing Procedures	7-7
7.3	Program Table Operation	7-9
7.3.1	Types of Operation	7-9
7.3.2	I/O Signals Related to Program Table Operation	7-11
7.3.3	Program Table Configuration	7-12
7.3.4	Settings in the Program Table	7-13
7.3.5	SigmaWin+ Procedures	7-14
7.3.6	State Transitions	7-26
7.3.7	Program Table Operation Examples	7-27
7.3.8	EVENT Examples	7-42
7.3.9	Output Response Times after /START-STOP Turns ON	7-43
7.4	Jog Speed Table Operation	7-44
7.4.1	Input Signals Related to Jog Operation	7-44
7.4.2	Jog Speeds	7-44
7.4.3	Jog Speed Table and Speed Selection Signals	7-45
7.4.4	SigmaWin+ Procedures	7-46
7.4.5	Jog Speed Table Operation Example	7-51
7.4.6	Timing of Signal Changes	7-52

7.5 ZONE Outputs7-53

- 7.5.1 ZONE Table and ZONE Signals7-53
- 7.5.2 Parameters Related to ZONE Signals7-54
- 7.5.3 SigmaWin+ Procedures7-55

7.1 Operation Functions

The following five operation functions are provided.

- **Homing**
Homing is used to define the machine origin when the power supply is turned ON to equipment that uses an incremental encoder.
Homing is not required for equipment that uses an absolute encoder because the positional relationship between the origin of the absolute encoder and the machine origin is set in a parameter.
- **Positioning with a Program Table**
You can register (program) positioning patterns in a table in advance and then use specifications from the host controller to specify the operation pattern to perform operation.
- **Registration**
If a trigger signal (/RGRT) is input from an external device during positioning, the motor will be moved for the registration distance (RDST) that is registered in the program table.
- **Constant Speed Operations with a Jog Speed Table**
This function supports constant-speed operation at preset jog speeds.
- **ZONE Outputs**
This function outputs a zone number to indicate when the motor is within a preset zone. The lower three programmable outputs are assigned.

7.2 Homing

Homing is used to define the machine origin when the power supply is turned ON to equipment that uses an incremental encoder. Turn OFF (mode 1) the /MODE 0/1 (Mode Switch Input) signal to enable performing homing.



WARNING

- If you are using an incremental encoder, always perform homing before you start program table operation. If you perform program table operation without performing homing, positions cannot be managed so correct positioning may not be possible. Unexpected machine operation, failure, or personal injury may occur.

7.2.1 I/O Signals Related to Homing

The following I/O signals are related to homing.

Input Signals Related to Homing

Input Signal	Description	Reference
/MODE 0/1	ON: Mode 0 (program table operation) OFF: Mode 1 (jog speed table operation or homing)	page 6-3
/HOME	The /HOME signal is turned ON to start homing.	page 6-3
/DEC	The /DEC signal is used to change the homing speed. The homing method is set in Pn642 = n.□□□X.	page 6-5

Output Signals Related to Homing

Output Signal	Description	Reference
/COIN	This signal turns ON when the current position is within the positioning completed width of the target position (final travel distance). It also turns ON when the motor stops after positioning is canceled, even if the target position was not reached.	*
/POSRDY	This signal turns ON when homing is completed.	–

* Refer to the following manual for details.

 Σ -7-Series Σ -7S SERVOPACK with Analog Voltage/Pulse Train References Product Manual (Manual No.: SIEP S800001 26)



Note

Homing is not performed for an absolute encoder. Therefore, error E61E (Encoder Mismatch Error) will occur if the /HOME signal turns ON.

7.2.2 Parameters Related to Homing

◆ Parameter That Specifies the Homing Method

Specify the homing method with Pn642 = n.□□□X.

Parameter		Meaning	When Enabled	Classification
Pn642 = n.□□□X	0 (default setting)	The current position when the power supply is turned ON is the origin. Homing is not executed.	After restart	Setup
	1	The /DEC signal and encoder phase C are used for performing homing.		
	2	Only the /DEC signal is used for performing homing.		
	3	Only the encoder phase C is used for performing homing.		

Note: A Homing Method Unspecified Error (E5DE) will occur if homing is attempted while Pn642 is set to n.□□□0.

◆ Parameter That Specifies the Homing Direction

Specify whether to perform homing in the forward or in the reverse direction with Pn643 = n.□□□X.

Parameter		Meaning	When Enabled	Classification
Pn643 = n.□□□X	0 (default setting)	Perform homing in the forward direction.	Immediately	Setup
	1	Perform homing in the reverse direction.		

◆ Parameter That Specifies the Origin

The value specified in Pn63C will be set as the current value when homing is completed.

Pn63C	Origin				
	Setting Range	Setting Unit	Default Setting	When Enabled	Classification
	-1,073,741,823 to +1,073,741,823	Reference units	0	After restart	Setup

◆ Parameter That Specifies the Homing Movement Speed

The following parameter sets the homing movement speed.

Pn644	Homing Movement Speed				
	Setting Range	Setting Unit	Default Setting	When Enabled	Classification
	1 to 199,999,999	1,000 refer- ence units/s	1,000	Immediately	Setup

◆ Parameter That Specifies the Homing Approach Speed

The following parameter sets the homing approach speed for homing. Operation details, such as changing to this speed, depends on the homing method.

Pn646	Homing Approach Speed				
	Setting Range	Setting Unit	Default Setting	When Enabled	Classification
	1 to 199,999,999	1,000 refer- ence units/s	1,000	Immediately	Setup

◆ Parameter That Specifies the Homing Creep Speed

The following parameter sets the homing creep speed. Operation details, such as changing to this speed, depends on the homing method.

Pn648	Homing Creep Speed				
	Setting Range	Setting Unit	Default Setting	When Enabled	Classification
	1 to 199,999,999	1,000 reference units/s	1,000	Immediately	Setup

◆ Parameter That Specifies the Homing Final Travel Distance

This parameter sets the travel distance after the motor changes to the creep speed. The stopping position when this travel is completed is set as the setting of Pn63C (Origin Position).

If a negative value is set, the movement direction will be reversed after the motor changes to the creep speed.

Pn64A	Homing Final Travel Distance				
	Setting Range	Setting Unit	Default Setting	When Enabled	Classification
	-1,073,741,823 to +1,073,741,823	Reference units	0	Immediately	Setup

7.2.3 Homing Procedures

Homing will start when the /HOME signal turns ON. Homing will be stopped if the /HOME signal turns OFF. If the /HOME signal turns ON while homing is stopped, homing will be restarted from where it was stopped.

If a jog speed table operation is performed with the /JOGP or /JOGN signal or if the mode is changed with the /MODE 0/1 signal while homing is stopped, homing will be canceled.

When Pn642 is set to n.□□□0 (the current position when the power supply is turned ON is the origin; homing is not executed), the origin position is defined as soon as the control power supply is turned ON.

There are three different origin patterns depending on the homing method that is specified in Pn642 = n.□□□X.

The homing procedure for each method is given in this section.

Using the /DEC Signal and Encoder Origin (Phase C) for Homing (Pn642 = n.□□□1)

- ① Turn ON the /HOME signal. Homing starts. The motor will rotate in the direction specified in Pn643 = n.□□□X (Homing Direction) at the speed specified in Pn644 (Homing Movement Speed).
- ② When the /DEC signal turns ON, the motor changes to the approach speed.
- ③ When the encoder's origin signal (phase C) is detected, the motor decelerates to the creep speed.
- ④ Homing is completed after the motor moves the final travel distance. Set Pn63C to the value of the current position where the motor is stopped.

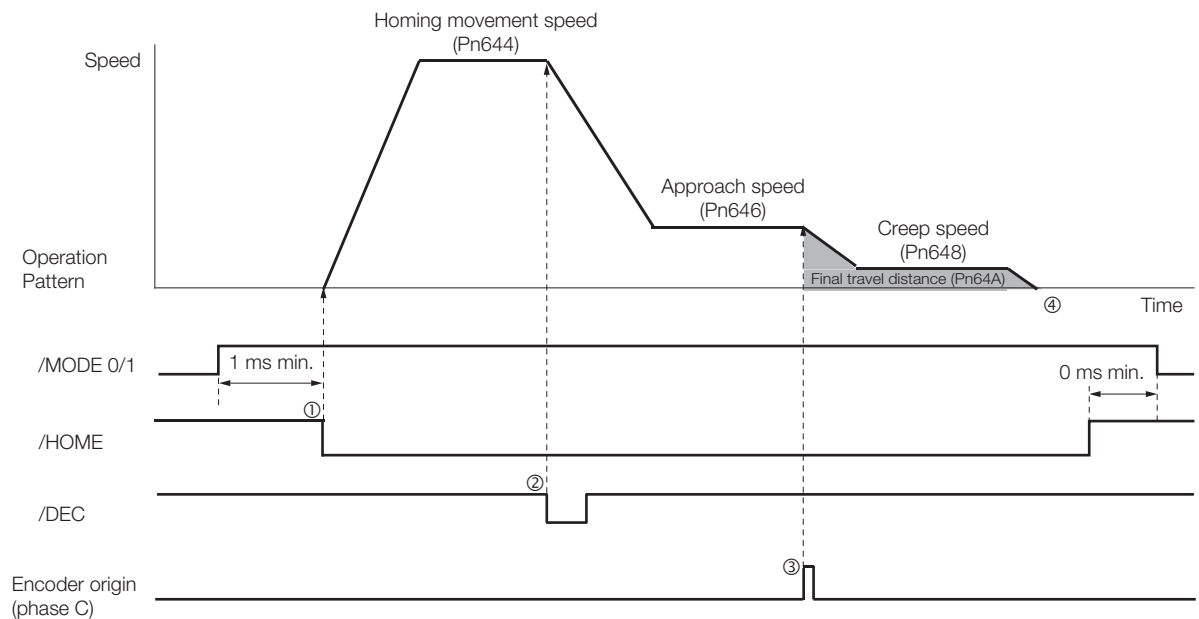

Using Only the /DEC Signal for Homing (Pn642 = n.□□□2)

- ① Turn ON the /HOME signal. Homing starts. The motor will rotate in the direction specified in Pn643 = n.□□□X (Homing Direction) at the speed specified in Pn646 (Approach Speed).
- ② When the /DEC signal turns ON, the motor decelerates to the creep speed.
- ③ Homing is completed after the motor moves the final travel distance. Set Pn63C to the value of the current position where the motor is stopped.

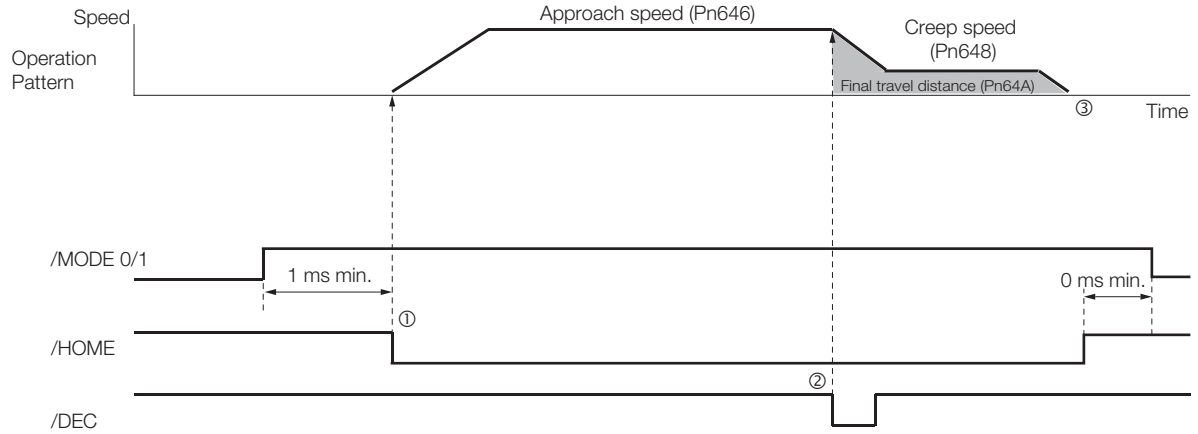

Using Only the Encoder Origin (Phase C) for the Homing (Pn642 = n.□□□3)

- ① Turn ON the /HOME signal. Homing starts. The motor will rotate in the direction specified in Pn643 = n.□□□X (Homing Direction) at the speed specified in Pn646 (Approach Speed).
- ② When the encoder's origin signal (phase C) is detected, the motor decelerates to the creep speed.
- ③ Homing is completed after the motor moves the final travel distance. Set Pn63C to the value of the current position where the motor is stopped.

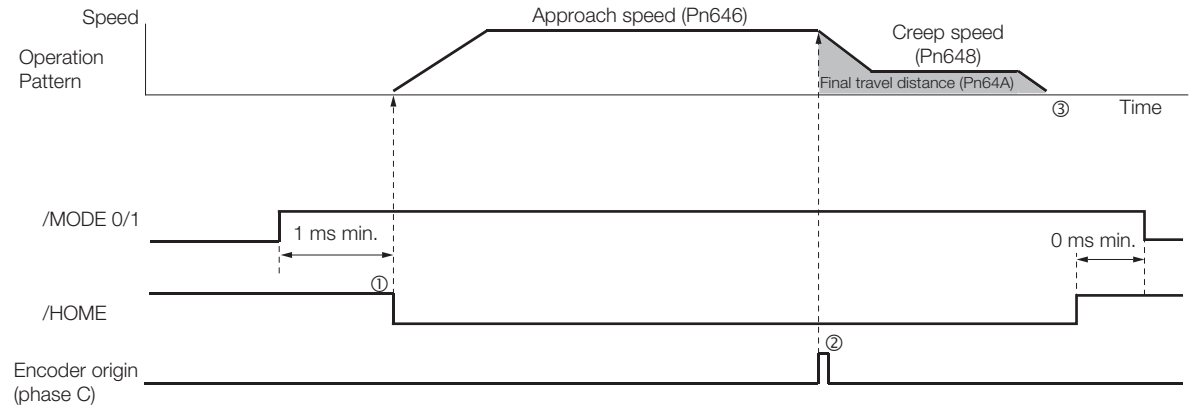

7.3 Program Table Operation

With program table operation, you can register (program) positioning patterns in a table in advance and then use commands from the host controller to specify the operation patterns to perform operation.

If you use program table operation, you do not need motion control programming in the host controller.

This section describes the types of operation that are possible, program table details, and SigmaWin+ operating procedures. It also provides examples of program table operation.

7.3.1 Types of Operation

Two types of program table operation are provided: positioning and registration.

Both types of operation are described in the rest of this section.



Note

This section describes program table operation using the item names and symbols that are registered in the program table. Refer to the following section for detailed information on the names and symbols.

7.3.4 Settings in the Program Table on page 7-13

Positioning

For positioning, the target positions are specified as the target positions (POS) in the program table. The motor is moved to the current target position.

Positioning is illustrated conceptually in the following figure.

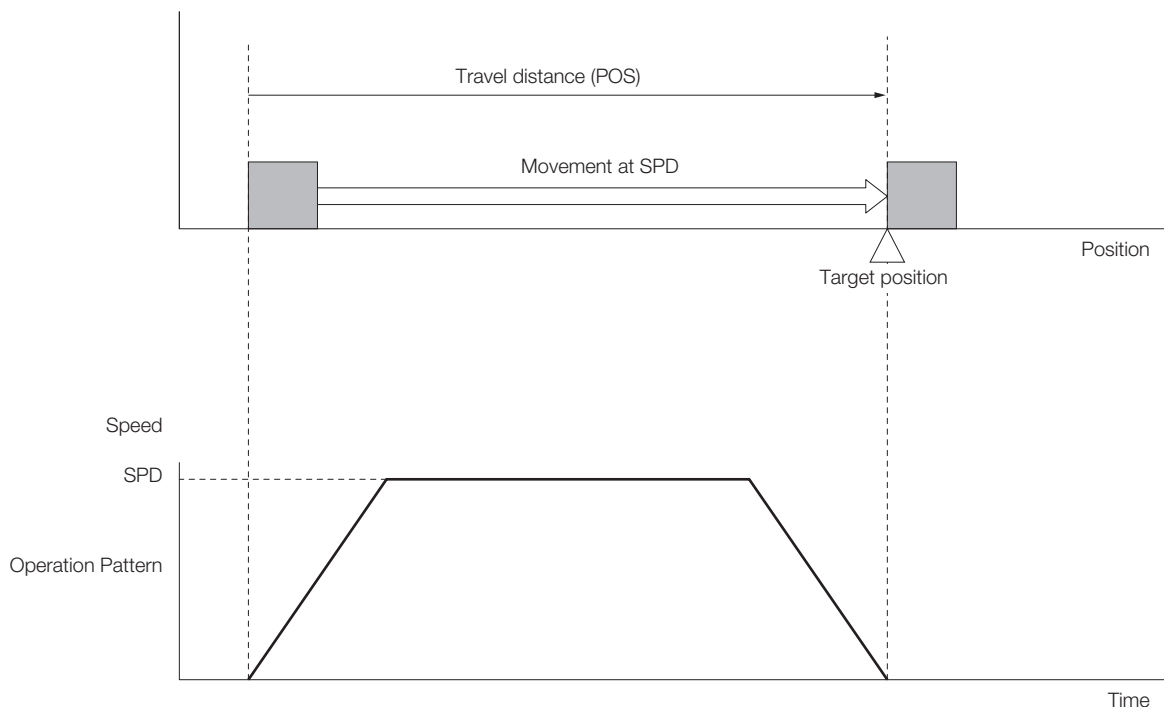

Registration Operation

If an external trigger signal (/RGRT) is input during travel (i.e., during positioning) toward a target position that is specified as the target position (POS) in the program table, the motor will move the registration distance (RDST) that is specified in the program table.

Registration operation is illustrated conceptually in the following figure.

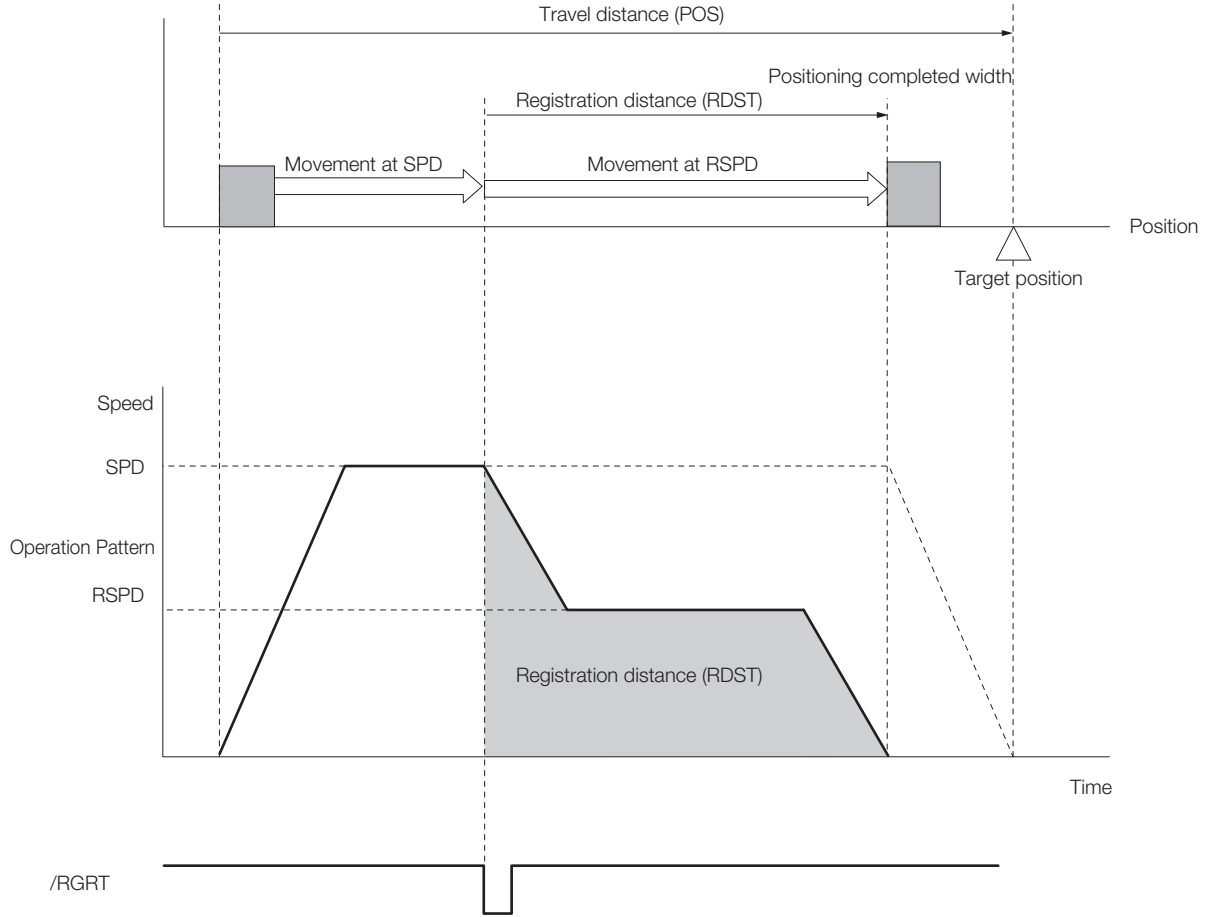

7.3.2 I/O Signals Related to Program Table Operation

The following I/O signals are related to program table operation.

Input Signals Related to Program Table Operation

Input Signal	Description	Reference
/MODE 0/1	ON: Mode 0 (program table operation) OFF: Mode 1 (jog speed table operation or homing)	page 6-3
/START-STOP	Turn ON this signal to start operation for the program step that is specified by the /SEL0 to /SEL4 (Program Step Selection Inputs) signals. Turn OFF this signal to stop program table operation and decelerate the motor to a stop.	page 6-3
/PGMRES	If this signal turns ON while a program table operation is stopped, the program table operation will be reset and canceled.*1	page 6-3
/SEL0 to /SEL4	These signals specify the program step number at which to start program table operation.*2	page 6-3
/RGRT	Registration operation starts on the rising edge of this signal.	page 6-3

*1. "Canceled" is the state in which the mode is mode 0, execution is not in a stopped state, and no program step has been executed.

*2. Use the five selection signals (/SEL0 to /SEL4) to specify between 0 and 31 for PGMSTEP. A value of 1 means that the signal is ON (active), and a value of 0 means that the signal is OFF (inactive).

PGMSTEP	Selection Signals				
	/SEL4	/SEL3	/SEL2	/SEL1	/SEL0
0	0	0	0	0	0
1	0	0	0	0	1
2	0	0	0	1	0
3	0	0	0	1	1
4	0	0	1	0	0
5	0	0	1	0	1
6	0	0	1	1	0
7	0	0	1	1	1
8	0	1	0	0	0
30	1	1	1	1	0
31	1	1	1	1	1

Output Signals Related to Program Table Operation

Output Signal	Description
/COIN	This signal turns ON when the target position (final travel distance) is within the positioning completed width. It also turns ON when the motor stops after positioning is canceled, even if the target position was not reached.
/POUT0 to /POUT4	You can set these signals as outputs. The output status is specified with POUT in the program steps.
/DEN	This signal turns ON at the completion of position reference distribution.

7.3.3 Program Table Configuration

The program table is a table that contains programming. You can enter up to 256 program steps.

The configuration of the program table is shown below. Each line in the table is called a program step. The steps are managed with program step numbers 0 to 255.

Note: You can program up to 256 program steps. You can use input signals (/SEL0 to /SEL4) to select program steps numbers 0 to 31.

Refer to the following section for details on the items that are set.

 7.3.4 Settings in the Program Table on page 7-13

PGM-STEP	POS	SPD	RDST	RSPD	ACC	DEC	POUT	EVENT	LOOP	NEXT
0										
1										
2										
:	:	:	:	:	:	:	:	:	:	:
255										



Note

After you edit the program table, save it to flash memory. Refer to the following section for the operating procedure.

 **◆ Saving the Program Table to Flash Memory in the SERVOPACK on page 7-24**

If you turn OFF the power supply before you save the program table in flash memory, the values that you set in the program table will be lost.

7.3.4 Settings in the Program Table

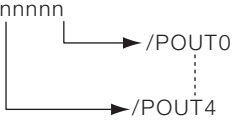
Item	Name	Meaning	Setting Procedure
PGM STEP	Program step	Numbers are used to identify the program steps in the program table.	The /SEL0 to /SEL4 signals are used to specify the program step.
POS	Target position	Specifies the target position.	Refer to the following section. ☞ POS on page 7-16
SPD	Positioning speed	Specifies the target speed for positioning.	Refer to the following section. ☞ SPD on page 7-17
RDST	Registration distance	Specifies the travel distance after the trigger signal (/RGRT) is input.	Refer to the following section. ☞ RDST on page 7-17
RSPD	Registration speed	Specifies the target speed for positioning after the trigger signal (/RGRT) is input.	Refer to the following section. ☞ RSPD on page 7-18
ACC	Acceleration rate	Specifies the acceleration rate to use to reach the positioning speed.	Refer to the following section. ☞ ACC and DEC on page 7-18
DEC	Deceleration rate	Specifies the deceleration rate from the positioning speed.	
POUT	Programmable output specification	<p>Specifies the output status of /POUT0 to /POUT4.</p>  <p>n = N, A, Z, or: N: Non-active (OFF) A: Active (ON) Z: ZONE signal</p> <p>A colon (:) indicates using the specification from the previous program step. Refer to the following section for information on the ZONE signals. ☞ 7.5 ZONE Outputs on page 7-53</p>	Refer to the following section. ☞ POUT (Output Signal) on page 7-20
EVENT	End condition	Specifies the condition to use to determine when the program step is completed. When the end condition is met and the number of executions specified for LOOP is completed, execution jumps to the program step specified by NEXT.	Refer to the following section. ☞ EVENT on page 7-20
LOOP	Number of loops	Specifies the number of times to execute the program step.	Refer to the following section. ☞ LOOP on page 7-21
NEXT	Next program step	Specify the program step to execute after completion of the current program step.	Refer to the following section. ☞ NEXT on page 7-22

 Important

- If you specify new positioning during positioning, an E53E (Movement Reference Duplication) error will occur and program table operation will be stopped. To restart, first turn ON the /PGM-RES signal to cancel program table operation.
- If the target position (POS) is \pm INFINITE and the registration distance (RDST) is "-" (no registration), you can change the program step to change the speed. In this case, the motor will simply change to the new speed. In all other cases, you cannot change the program step to change the speed. An E53E (Movement Reference Duplication) error will occur.
- You can change the settings in the program table only when program table operation is canceled. If program table operation is in progress or stopped, you cannot change the settings, even for program steps that are not currently being executed. An E5EE (Execution Not Possible during Program Table Operation) error will occur.

7.3.5 SigmaWin+ Procedures

You use the SigmaWin+ to edit, write, and save the program table.

A flowchart is provided below.

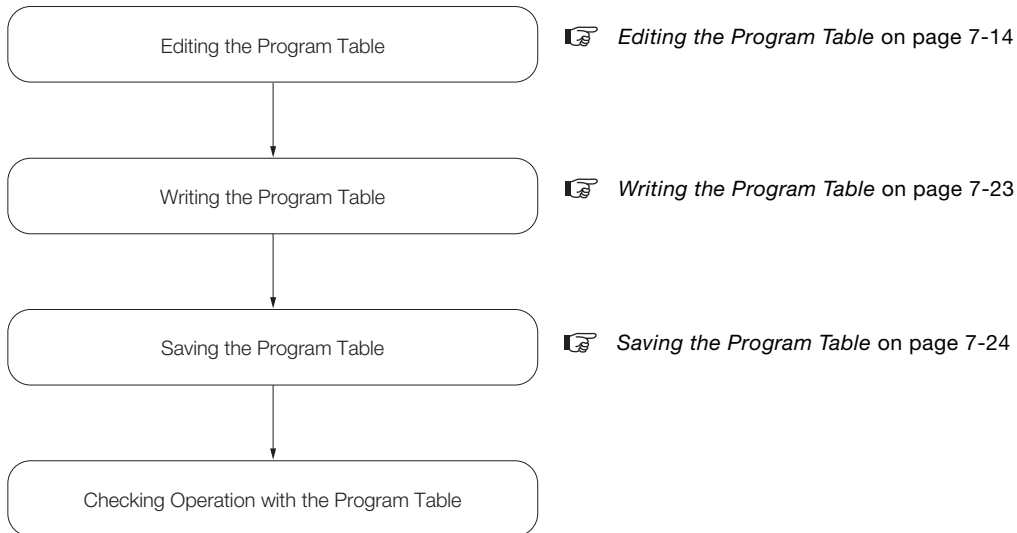



Editing the Program Table

◆ **Displaying the Program Table Editing Dialog Box.**

Select ***Edit Program Table*** from the menu bar of the Main Window of the SigmaWin+.

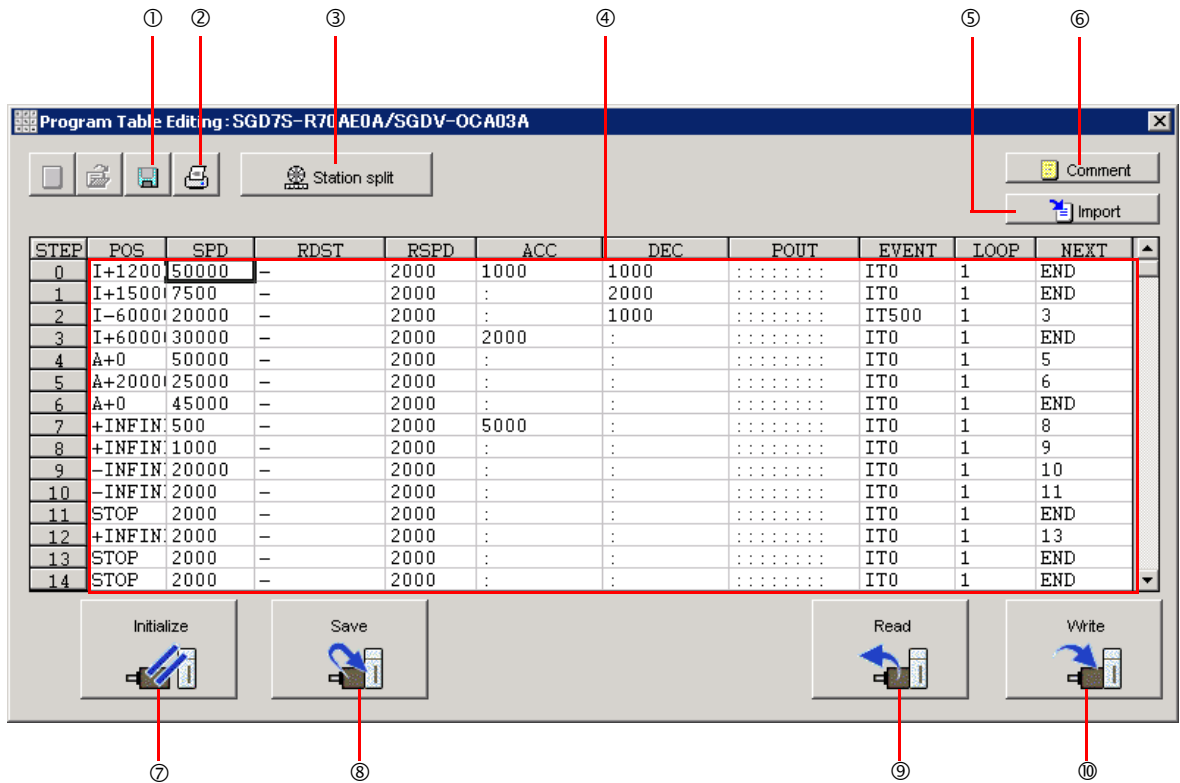
◆ Program Table Editing Dialog Box



No.	Item	Description
①	Save Button	Saves the program table currently displayed on the SigmaWin+ in a file on the computer.
②	Print Button	Used to print the program table.
③	Station split Button	Splits the valid coordinate range (i.e., the range defined by Pn63A to Pn638) into equal intervals and sets the resulting positions in the program table.
④	Program table editing cells	<p>You edit the program table here. The colors of the cells will change as follows:</p> <p>White: The values in SERVOPACK RAM is the same as the value in the SigmaWin+ table cells.</p> <p>Green: If any changes are made, the rows that include the changes change to green. When you write the changes, the cells change to white.</p> <p>Red: If there is a setting error, the row is displayed in red. The Write Button will be disabled.</p> <p>Refer to the following section for the table cell editing procedures.  ◆ <i>Editing Procedures</i> on page 7-16</p>
⑤	Import Button	Imports a file on the computer to a program table in SigmaWin+.
⑥	Comment Button	Lets you enter a comment for the program table. The comment is also saved when you click the Save Button.
⑦	Initialize Button	Initializes the flash memory for the program table in the SERVOPACK and restores the default settings.
⑧	Save Button	Saves the program table in RAM in the SERVOPACK to flash memory. If you save the program table to flash memory, it will not be lost even if you turn OFF the power supply. The next time you turn ON the power supply, the program table will be written to RAM.
⑨	Read Button	Reads the program table in RAM in the SERVOPACK to the SigmaWin+.
⑩	Write Button	Writes the program table currently displayed on the SigmaWin+ to the SERVOPACK. The program table is written only to RAM. Writing the program table enables program operation.

◆ Editing Procedures

The following two ways are used to edit the program table.

Note: The method that is used depends on the item.

- **Items That Are Entered Directly**

Click the cell to edit the item. Enter the setting directly.

STEP	POS	SPD
0	A-5000	200000
1	STOP	100000
2	STOP	100000

- **Items with Dialog Boxes**

Double-click the cell to display the dialog box for editing. Make the settings in the dialog box.

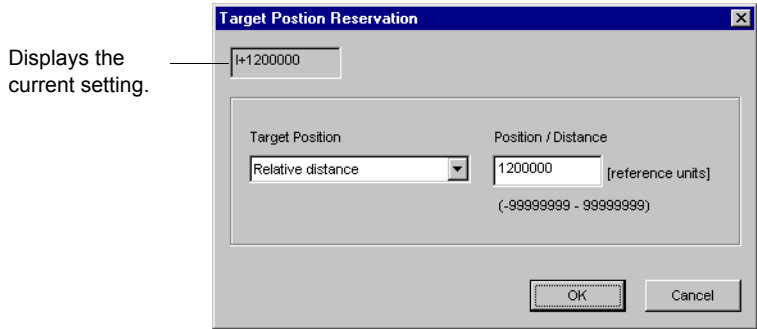

Setting procedures are provided below for each item.

■ POS

Set the target positions.

1. **Double-click the cell to edit.**

The Target Position Reservation Dialog Box will be displayed.

2. **Set the target position and the position/distance.**

Information The **Position/Distance** setting is enabled when you set the target position to an absolute position or relative distance.

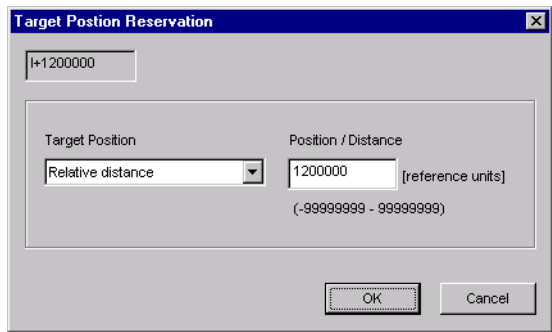

- Target position

Selected Item	Description	Display in Program Table
Absolute position	Use this setting to specify the target position directly.	A ± Position
Relative distance	Use this setting to specify the relative position (travel distance) from the previous step.	I ± Distance
Infinity (Positive direction)* ¹	Constant-speed operation is performed in the forward direction.	+INFINITE
Infinity (Negative direction)* ¹	Constant-speed operation is performed in the reverse direction.	-INFINITE
Stop [default setting]	The axis is not moved. Use this setting to stop constant-speed operation when the target position is set to infinite.	STOP
Consecutive stop* ²	Specify the absolute target position within the rotational coordinates to perform positioning after constant-speed operation.	S + Position
Without reference	The axis is not moved. This setting can be used only when POUT is specified.	–

*1. You can use the INFINITE settings for the target positions only for rotational coordinates (Pn637 ≠ n.□□□0) or when the software limits are not used (Pn637 and Pn63A = 0). An error will occur if you use an INFINITE setting for linear coordinates or when the software limits are enabled.

*2. You can use consecutive stop settings for the target positions for rotational coordinates (Pn637 ≠ n.□□□0) or when the target position in the previous step is set to INFINITE. A consecutive stop setting will result in an error if linear coordinates are being used or if the target position for the previous step is not INFINITE. Also, you cannot use the consecutive stop setting in combination with a speed change for an infinite target position setting.

- Position/Distance

Unit	Setting Range	Default Setting
Reference units	-1,073,741,823 to +1,073,741,823	STOP

3. Click the OK Button.

This concludes the setting procedure.

■ SPD

Specify the target speeds for positioning.

Select the cells to edit and enter the values directly.

Unit	Setting Range	Default Setting
1,000 reference units/min	1 to 199,999,999	1,000

■ RDST

Set the registration absolute distance.

1. Double-click the cell to edit.

The Registration Relative Position Dialog Box will be displayed.

Using Registration

2. Clear the selection of the **No registration** Check Box and enter the registration absolute distance.

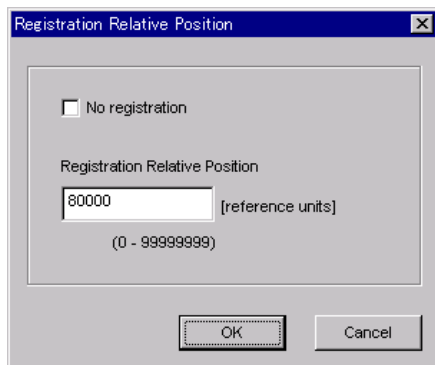

Not Using Registration

2. Select the **No registration** Check Box.

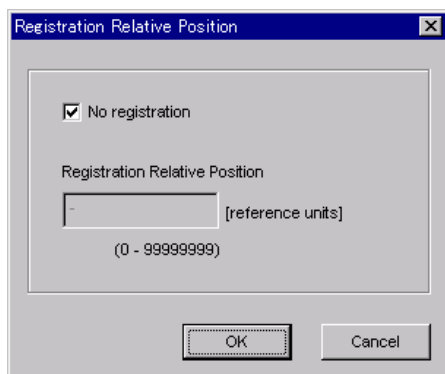

3. Click the **OK** Button.

This concludes the setting procedure.

■ RSPD

Set the registration speed.

Select the cell to edit and set the value directly.

Unit	Setting Range	Default Setting
1,000 reference units/min	1 to 1,073,741,823	1,000

■ ACC and DEC

Set the acceleration rate (ACC) and deceleration rate (DEC) for movement.

1. Double-click a cell under **ACC** or **DEC**.
The Acceleration/Deceleration Dialog Box will be displayed.

2. Set the acceleration and deceleration rates.

The **Same as previous step** Check Boxes are selected by default.

The screenshot shows a dialog box titled "Acceleration/Deceleration". It has two main sections: "Acceleration" and "Deceleration". In the "Acceleration" section, there is a checked checkbox labeled "Same as previous step", an empty input field, the text "(1 - 99999999)", and the unit "[1000reference units/min/ms]". The "Deceleration" section has a similar layout with a checked checkbox, an empty input field, the text "(1 - 99999999)", and the unit "[1000reference units/min/ms]". At the bottom, there are "OK" and "Cancel" buttons.

To use different values from the previous step, clear the selections of the **Same as previous step** Check Boxes and enter the values directly.

The screenshot shows the same "Acceleration/Deceleration" dialog box. In this view, the "Same as previous step" checkboxes for both sections are unchecked. The "Acceleration" input field now contains the value "1000" and the "Deceleration" input field contains "1500". The units remain "[x1000reference units/min/ms]". The "OK" and "Cancel" buttons are still present at the bottom.

Unit	Setting Range	Default Setting
1,000 reference units/min/ms	1 to 199,999,999	:

3. Click the OK Button.

This concludes the setting procedure.



Note

If you select the **Same as previous step** Check Boxes for the starting program step, the settings of the acceleration/deceleration parameters (Pn63E: acceleration rate, Pn640: deceleration rate) that were set before programmed operation was started will be used.

■ **POUT (Output Signal)**

Specify the signals to output immediately after program step execution is started.

Note: If you want to output the signal at the end of the step, specify POUT as POS = "-" in the next step.

1. Double-click the cell to edit.

The Output Signal Dialog Box will be displayed.

Note: Output signals 5 to 7 cannot be used for the FT79 SERVOPACKs.

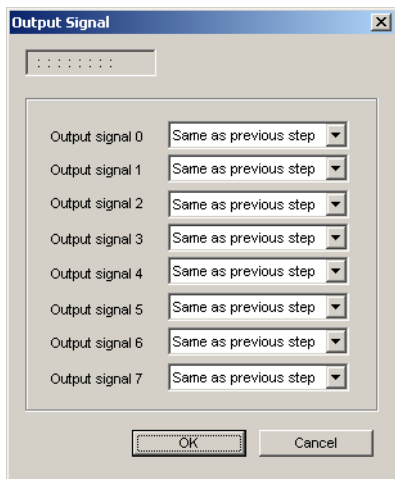

2. Select the settings for output signals 0 to 4 in the boxes.

The corresponding terminals are given below.

Output signal 0: /POUT0 terminal

Output signal 1: /POUT1 terminal

Output signal 2: /POUT2 terminal

Output signal 3: /POUT3 terminal

Output signal 4: /POUT4 terminal

Selection Items	Description	Program Table Notation
Active	Always ON	A
Not Active	Always OFF	N
Same as previous step	Continues previous state.	:
ZONE	Sets the ZONE signal (/Z0 to /Z3) that corresponds to that digit.	Z

3. Click the OK Button.

This concludes the setting procedure.

■ **EVENT**

Specify the conditions to complete execution of the program steps.

When the end condition is met and the number of executions specified for LOOP is completed, execution jumps to the program step specified by NEXT. If the number of executions specified for LOOP has not been completed, the step will be executed again.

1. Double-click the cell to edit.

The Event Dialog Box will be displayed.

2. Set the condition and the wait time.

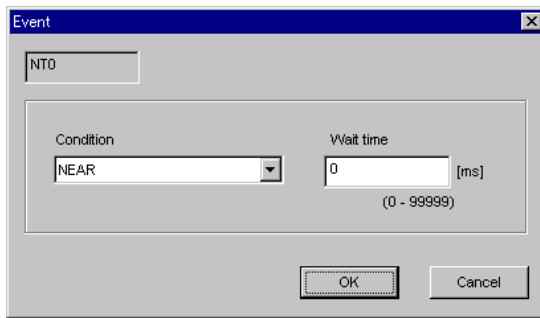

- Condition

Selected Item	Description	Display in Program Table
Positioning complete [default setting]	The step ends when the /COIN (Positioning Completion Output) signal turns ON (closes).	I
NEAR	The step ends when the /NEAR signal width is entered.	N
Command Issuance Completion	The step ends when position reference distribution is completed (DEN).	D
SEL0, SEL1, ...	The step ends when the /SELx input signal turns ON (closes). x = 0 to 4	SELx
Wait time	Execution waits for n milliseconds after the /COIN (Positioning Completion Output) signal turns ON (closes).	ITn
	Execution waits for n milliseconds after the /NEAR (Near Output) signal turns ON (closes).	NTn
	Execution waits for n milliseconds after position reference distribution is completed (DEN).	DTn
	Execution waits for n milliseconds after the SELx input signal turns ON (closes).	SELxTn
Same as previous step	The condition from the previous program step is used.	:

- Wait Time

Unit for "n"	Setting Range of "n"	Default Setting
ms	0 to 99,999	IT0

3. Click the OK Button.

This concludes the setting procedure.

■ LOOP

Specify the number of times to execute the step.

Note: NEXT is accessed after the number of executions specified with LOOP has been completed. You cannot specify LOOP across more than one program step.

Select the cell to edit and set the value directly.

Unit	Setting Range	Default Setting
Times	1 to 99,999	1

■ NEXT

Specify the operation to perform after execution of the current program step is completed.

1. Double-click the cell to edit.

The Next Step Dialog Box will be displayed.

Executing a Next Step

2. Clear the selection of the **END** Check Box and set a value between 0 and 255 for the next step number.

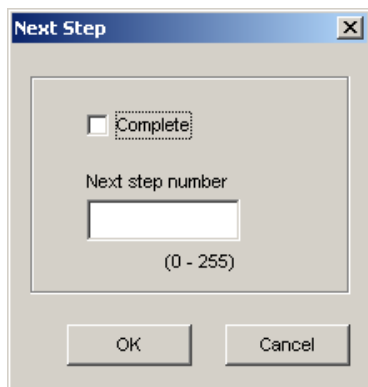

Unit	Setting Range	Default Setting
–	0 to 255	END*

* Program table operation is ended and canceled.

Ending Program Execution at the Current Step

2. Select the **Complete** Check Box.

When execution of the current program step is completed, program execution will be canceled.

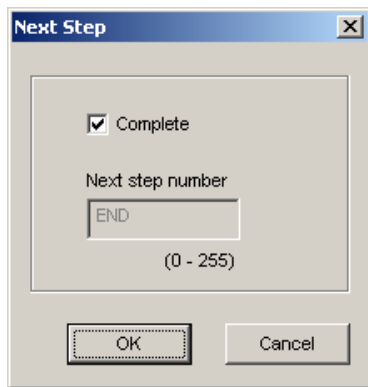

3. Click the **OK** Button.

This concludes the setting procedure.

Writing the Program Table

You can write the edited program table to SERVOPACK RAM to operate the SERVOPACK according to the program table.



Note

1. Make sure that the system is in SERVO OFF state when you write the program table.
2. The program table that is written will be deleted when the power supply to the SERVOPACK is turned OFF. Before you turn OFF the power supply to the SERVOPACK, save the program table from RAM to flash memory. Refer to the following section for the procedure.
Saving the Program Table on page 7-24

1. Click the Write Button in the Program Table Editing Dialog Box.

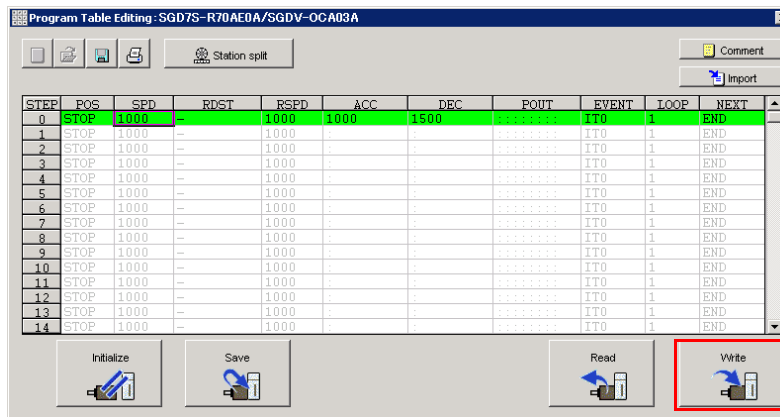

The Write Dialog Box will be displayed.

2. Click the OK Button.



The program table edited on the SigmaWin+ will be written to the SERVOPACK and all edited rows will change to white.

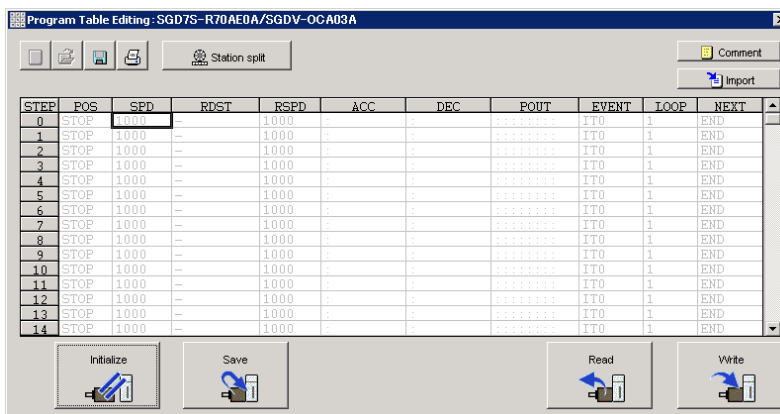

This concludes the writing procedure.

Saving the Program Table

◆ Saving the Program Table to Flash Memory in the SERVOPACK

To prevent the program table from being deleted when the power supply to the SERVOPACK is turned OFF, you must save it to flash memory in the SERVOPACK. The program table that is saved in the flash memory is automatically loaded each time the power supply is turned ON. We recommend that you save the program table that is normally used for operation in this flash memory.

There are the following two ways to save the program table to flash memory in the SERVOPACK.

- Save it from the Edit Program Dialog Box.
- Save it with Fn060 (Edit/Save Program Table) on a Digital Operator.

Use the following procedure to save the program table from the Edit Program Dialog Box.

1. Click the **Save** Button in the Program Table Editing Dialog Box.

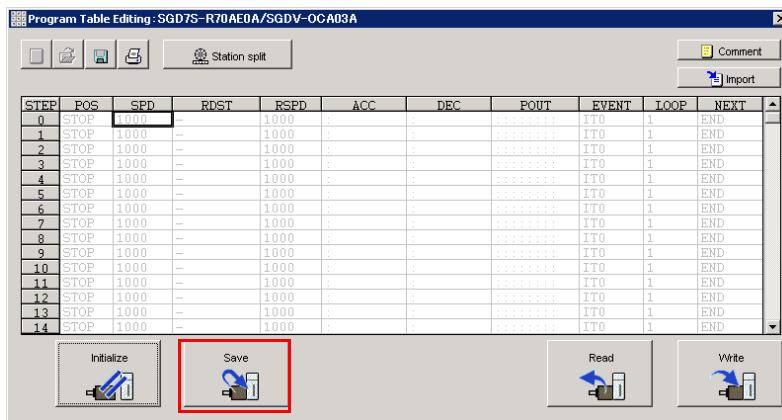

The Save Table Dialog Box will be displayed.

2. Click the **OK** Button.

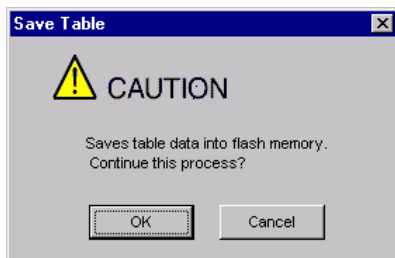

This concludes the saving procedure.

◆ Saving the Program Table to a Computer File

You can save the program table to a file on the computer. Use computer files to back up program tables.

1. Click the Save Button.

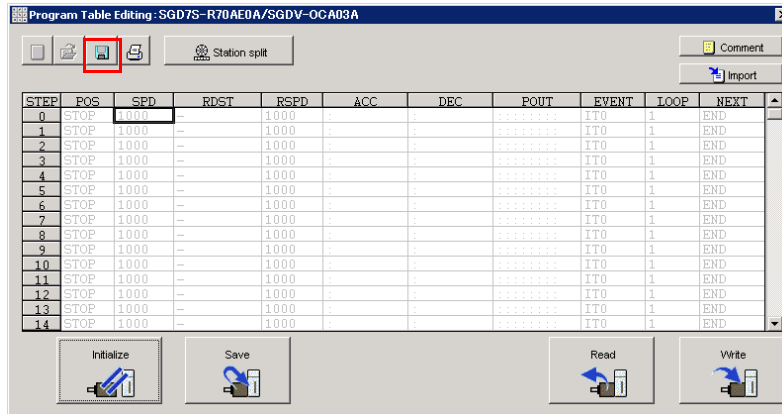

The Save As Dialog Box will be displayed.

2. Specify the save location and file name.

You can set any file name. However, you cannot change the file name extension.

Information You can also set a comment.

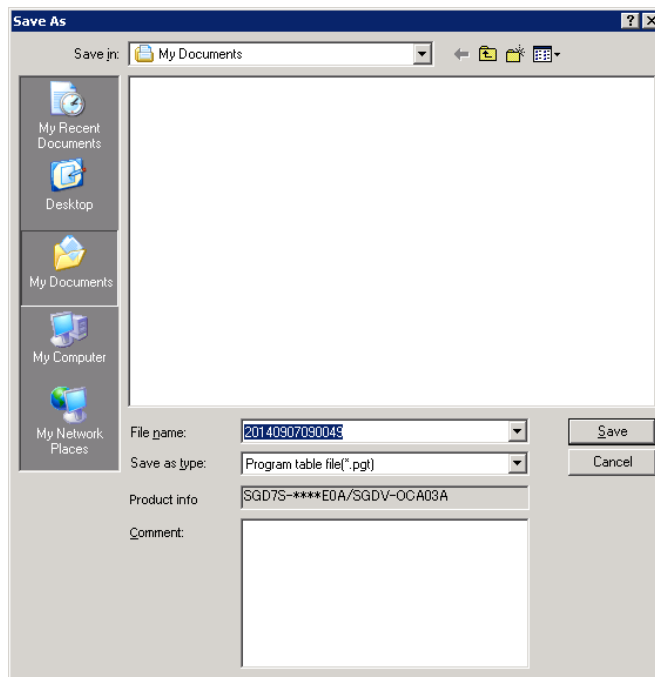

Information You can use the **Import** Button to load the program table saved in a file to the SERVO-PACK.

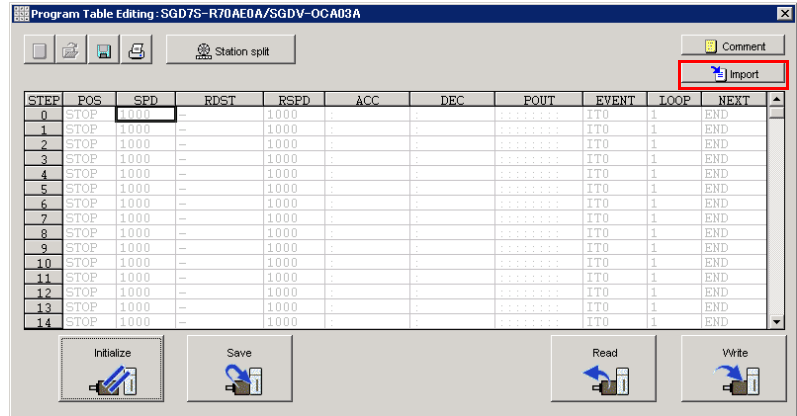

This concludes the saving procedure.

7.3.6 State Transitions

Program table operation can be in any of three states: Canceled, operating, or stopped.

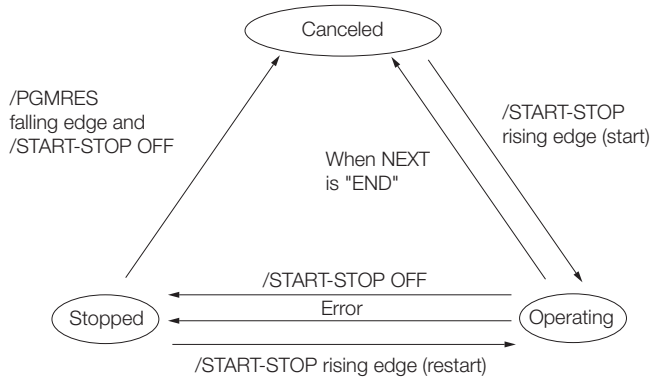

	Transition Condition		State Transition		
	/START-STOP	/PRGRES	Canceled	Operating	Stopped
Transition			● →		
				● →	
			←		●
				←	●

- Note: 1. "Canceled state" means that the mode is mode 0, execution is not in a stopped state, and no program step is being executed.
 2. The status will also change from operating to canceled in the following case: The next step is set to END in the program table.
 The status will also change from operating to stopped in the following case: An error occurs during operation.

 **Note** If the program table operation is restarted after it is stopped because of an error, the PGMSTEP in which the error occurred will be skipped and execution will be restarted from the PGMSTEP specified by NEXT. (If the operation has not been executed for the number of times specified in the LOOP, the next LOOP will be executed.)

7.3.7 Program Table Operation Examples

This section provides the following 12 examples to show the timing of the I/O signals related to program table operation.

In the following examples, it is assumed that homing has been completed to define the origin.

Refer to the following section for a timing chart from when the power supply to the equipment is turned ON until homing is completed when an incremental encoder is used.

 7.2 Homing on page 7-4

No.	Item	Reference
1	Specifying the Program Steps to Execute One at a Time	page 7-28
2	Specifying the Next Step to Execute in the NEXT Setting	page 7-29
3	Specifying the Number of Times to Execute a Program Step	page 7-30
4	Pausing Program Table Operation	page 7-31
5	Outputting POUT Signals for the Specified Time	page 7-33
6	Specifying SEL Signals as Events	page 7-34
7	Combining Positioning with Constant-Speed Operation	page 7-35
8	Performing Registration	page 7-36
9	Pausing Registration	page 7-37
10	Turning ON the /RGRT Signal While Program Table Operation Is Stopped	page 7-38
11	Using Consecutive Stops	page 7-39
12	Resetting Program Table Operation	page 7-41

Specifying the Program Steps to Execute One at a Time

In this example, the program table contains steps 0 to 4, but only program steps 3 and 4 are executed.

Step 3 performs relative positioning for 100,000 reference units at a speed of 15,000,000 references units/min. The acceleration/deceleration rates that are set in Pn63E (Acceleration Rate) and Pn640 (Deceleration Rate) are used.

Step 4 performs relative positioning for 200,000 reference units at a speed of 30,000,000 references units/min with the same acceleration/deceleration rates as step 3.

The program table for this positioning is shown below.

PGM-STEP	POS	SPD	RDST	RSPD	ACC	DEC	POUT	EVENT	LOOP	NEXT
0	I+100000	15000	-	1000	:	:	NNNNA	IT2000	1	END
1	A+100000	15000	-	1000	:	:	NNNAN	IT2000	1	END
2	I+300000	15000	-	1000	:	:	NNANN	IT2000	1	END
3	I+100000	15000	-	1000	:	:	NANNN	IT2000	1	END
4	I+200000	30000	-	1000	:	:	ANNNN	IT2000	1	END

• Operating Procedure

- ① Turn ON the /MODE 0/1 signal to change to mode 0.
- ② Set the /SEL0 to /SEL4 signals to 3 (i.e., turn ON /SEL0 and /SEL1) to specify program step 3.
- ③ Turn ON the /START-STOP signal to start program table operation.
The /COIN signal turns OFF and the /POUT3 signal turns ON.
- ④ When positioning is completed to the target position, the /COIN signal turns ON.
- ⑤ Turn OFF the /START-STOP signal.
- ⑥ Set the /SEL0 to /SEL4 signals to 4 (turn ON /SEL2) to specify program step 4.
- ⑦ Turn ON the /START-STOP signal to start program table operation.
The /POUT4 signal turns ON.
- ⑧ When positioning is completed to the target position, the /COIN signal turns ON.

• Operation Pattern and Related Signal Timing

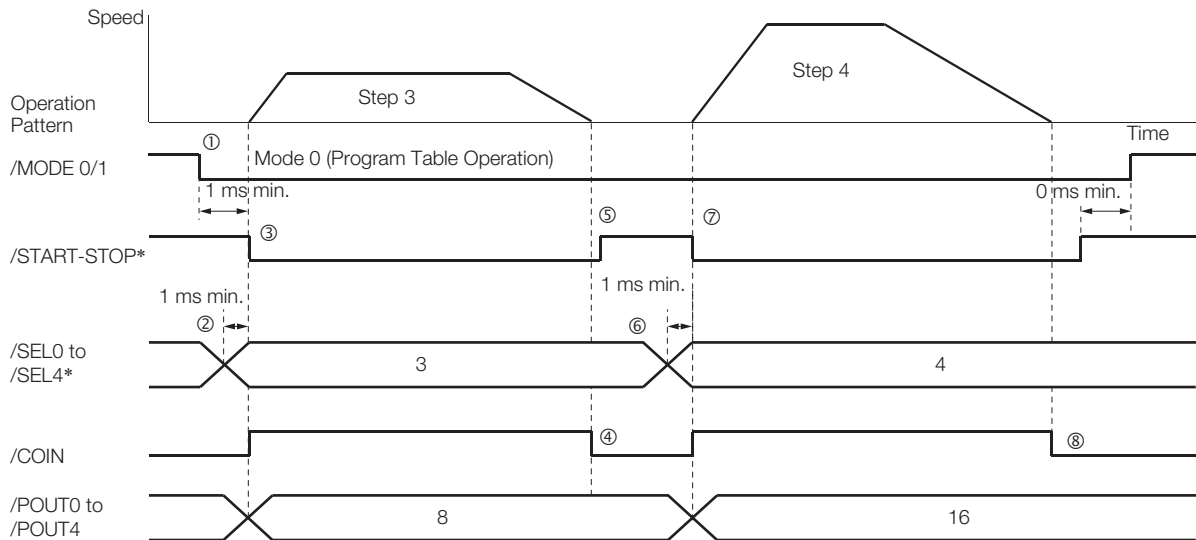

* Do not change /SEL0 to /SEL7 for 4 ms after turning ON the /START-STOP signal.

Specifying the Next Step to Execute in the NEXT Setting

In this example, repeated positioning is performed using program steps 0 and 1.

Step 0 performs relative positioning for 300,000 reference units at a speed of 15,000,000 reference units/min. The acceleration rate is 400,000,000 reference units/min/ms and the deceleration rate is 200,000,000 reference units/min/ms.

Step 1 performs relative positioning for -400,000 reference units at a speed of 20,000,000 reference units/min. The acceleration rate is 500,000,000 reference units/min/ms and the deceleration rate is 250,000,000 reference units/min/ms.

The program table for this positioning is shown below.

PGM-STEP	POS	SPD	RDST	RSPD	ACC	DEC	POUT	EVENT	LOOP	NEXT
0	I+300000	15000	-	1000	400000	200000	NNNNA	IT1000	1	1
1	I-400000	20000	-	1000	500000	250000	NNNAN	IT2000	1	0

• Operating Procedure

- ① Turn ON the /MODE 0/1 signal to change to mode 0.
- ② Set the /SEL0 to /SEL4 signals to 0 to specify program step 0.
- ③ Turn ON the /START-STOP signal to start program table operation.
The /COIN signal turns OFF and the /POUT0 signal turns ON.
- ④ When positioning is completed to the target position, the /COIN signal turns ON.
- ⑤ After a wait time of 1 second, execution of the program step specified with the NEXT setting (program step 1) is executed.
The /COIN and POUT0 signals turn OFF and the /POUT1 signal turns ON.
- ⑥ When positioning is completed to the target position, the /COIN signal turns ON.
- ⑦ After a wait time of 2 seconds, execution of the program step specified with the NEXT setting (program step 0) is executed.
- ⑧ Steps 4 to 7 are repeated.

• Operation Pattern and Related Signal Timing

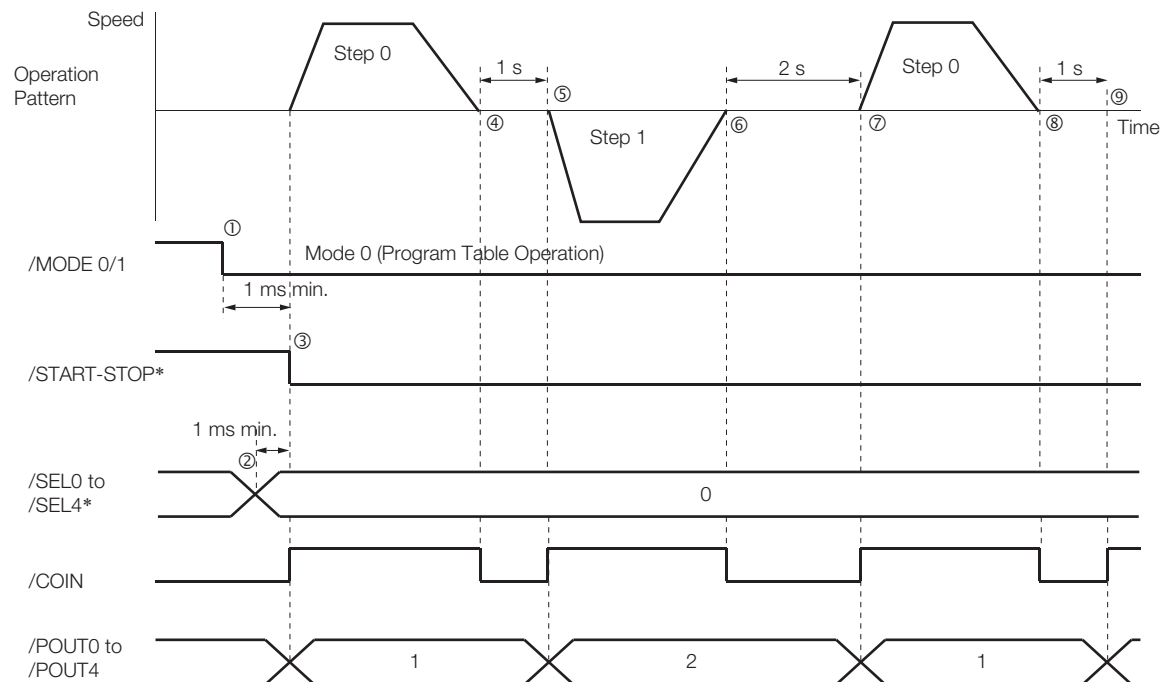

* Do not change /SEL0 to /SEL7 for 4 ms after turning ON the /START-STOP signal.

Specifying the Number of Times to Execute a Program Step

In this example, program step 0 is executed and then step 1 is executed three times.

Step 0 performs relative positioning for 300,000 reference units at a speed of 15,000,000 references units/min. The acceleration rate is 400,000,000 reference units/min/ms and the deceleration rate is 200,000,000 reference units/min/ms.

Step 1 performs relative positioning for -400,000 reference units at a speed of 20,000,000 references units/min. The acceleration rate is 500,000,000 reference units/min/ms and the deceleration rate is 250,000,000 reference units/min/ms. The number of loops for step 1 is set to 2.

The program table for this positioning is shown below.

PGM-STEP	POS	SPD	RDST	RSPD	ACC	DEC	POUT	EVENT	LOOP	NEXT
0	I+300000	15000	-	1000	400000	200000	NNNNA	IT1000	1	1
1	I-400000	20000	-	1000	500000	250000	NNNAN	IT2000	3	END

• Operating Procedure

- ① Turn ON the /MODE 0/1 signal to change to mode 0.
- ② Set the /SEL0 to /SEL4 signals to 0 to specify program step 0.
- ③ Turn ON the /START-STOP signal to start program table operation.
The /COIN signal turns OFF and the /POUT0 signal turns ON.
- ④ When positioning is completed to the target position, the /COIN signal turns ON.
- ⑤ After a wait time of 1 second, execution of the program step specified with the NEXT setting (program step 1) is executed.
The /COIN and /POUT0 signals turn OFF and the /POUT1 signal turns ON.
- ⑥ When positioning is completed to the target position, the /COIN signal turns ON.
- ⑦ After a wait time of 2 seconds, execution of program step 1 is started twice.
The /COIN signal turns OFF.
- ⑧ When positioning is completed to the target position, the /COIN signal turns ON.
- ⑨ After a wait time of 2 seconds, execution of program step 1 is started a third time.
The /COIN signal turns OFF.
- ⑩ When positioning is completed to the target position, the /COIN signal turns ON.
- ⑪ After a wait time of 2 seconds, program table operation is ended and the /POUT1 signal turns OFF.

• Operation Pattern and Related Signal Timing

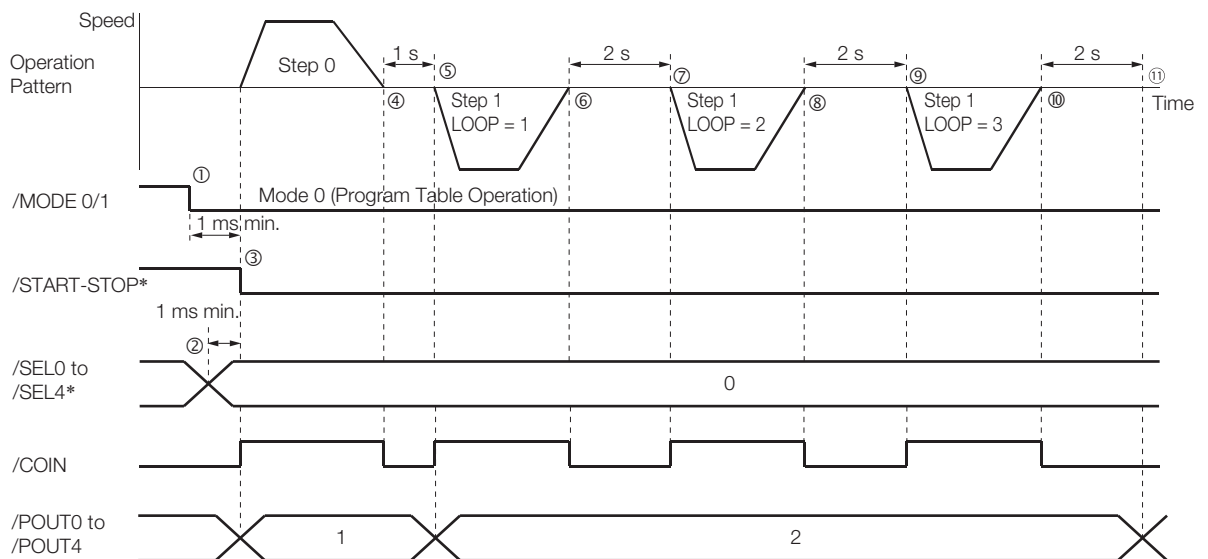

* Do not change /SEL0 to /SEL7 for 4 ms after turning ON the /START-STOP signal.

Pausing Program Table Operation

This example shows how to turn OFF the /START-STOP signal to temporarily stop program table operation and then turn ON the /START-STOP signal to execute the remainder of the step.

Execution is temporarily stopped and then restarted during execution of program step 4.

The program table for this positioning is shown below.

PGM-STEP	POS	SPD	RDST	RSPD	ACC	DEC	POUT	EVENT	LOOP	NEXT
0	I+100000	15000	-	1000	400000	200000	NNNNA	IT1000	1	END
1	A+100000	15000	-	1000	:	:	NNNAN	IT2000	1	END
2	I+300000	15000	-	1000	:	:	NNANN	IT3000	1	END
3	I+100000	15000	-	1000	:	:	NANNN	IT2000	1	END
4	I+200000	30000	-	1000	200000	200000	ANNNN	IT2000	1	END

• Operating Procedure

- ① Turn ON the /MODE 0/1 signal to change to mode 0.
- ② Set the /SEL0 to /SEL4 signals to 4 (i.e., turn ON /SEL2) to specify program step 4.
- ③ Turn ON the /START-STOP signal to start program table operation.
The /COIN signal turns OFF and the /POUT4 signal turns ON.
- ④ Turn OFF the /START-STOP signal to stop program table operation.
- ⑤ The Servomotor decelerates to a stop and the /COIN signal turns ON.
- ⑥ Turn ON the /START-STOP signal to restart program table operation.
The remaining travel distance will be executed. The /SEL0 to /SEL4 signals are not latched at this time.
- ⑦ When positioning is completed to the target position, the /COIN signal turns ON.

• Operation Pattern and Related Signal Timing

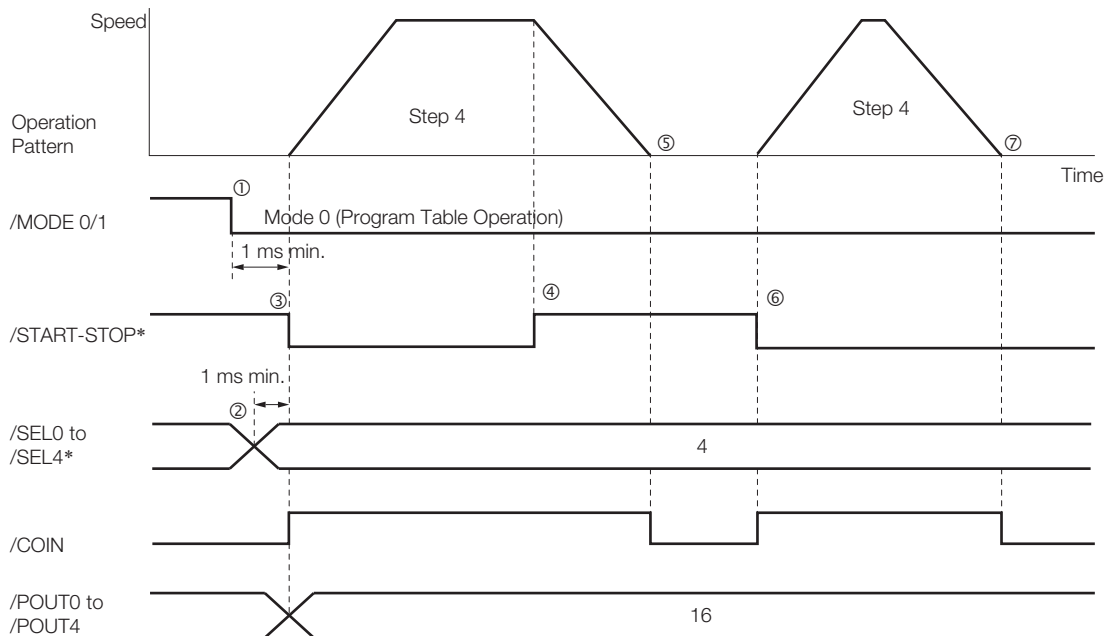

* Do not change /SEL0 to /SEL7 for 4 ms after turning ON the /START-STOP signal.

As described below, operation is restarted even when the /START-STOP signal is turned ON even during deceleration after the /START-STOP signal is turned OFF.

- Operating Procedure
 - ① Turn ON the /MODE 0/1 signal to change to mode 0.
 - ② Set the /SEL0 to /SEL4 signals to 4 (i.e., turn ON /SEL2) to specify program step 4.
 - ③ Turn ON the /START-STOP signal to start program table operation.
The /COIN signal turns OFF and the /POUT4 signal turns ON.
 - ④ Turn OFF the /START-STOP signal to stop program table operation.
 - ⑤ Turn ON the /START-STOP signal while the Servomotor is decelerating. Program table operation is restarted.
The remaining travel distance will be executed.
 - ⑥ When positioning is completed to the target position, the /COIN signal turns ON.

• Operation Pattern and Related Signal Timing

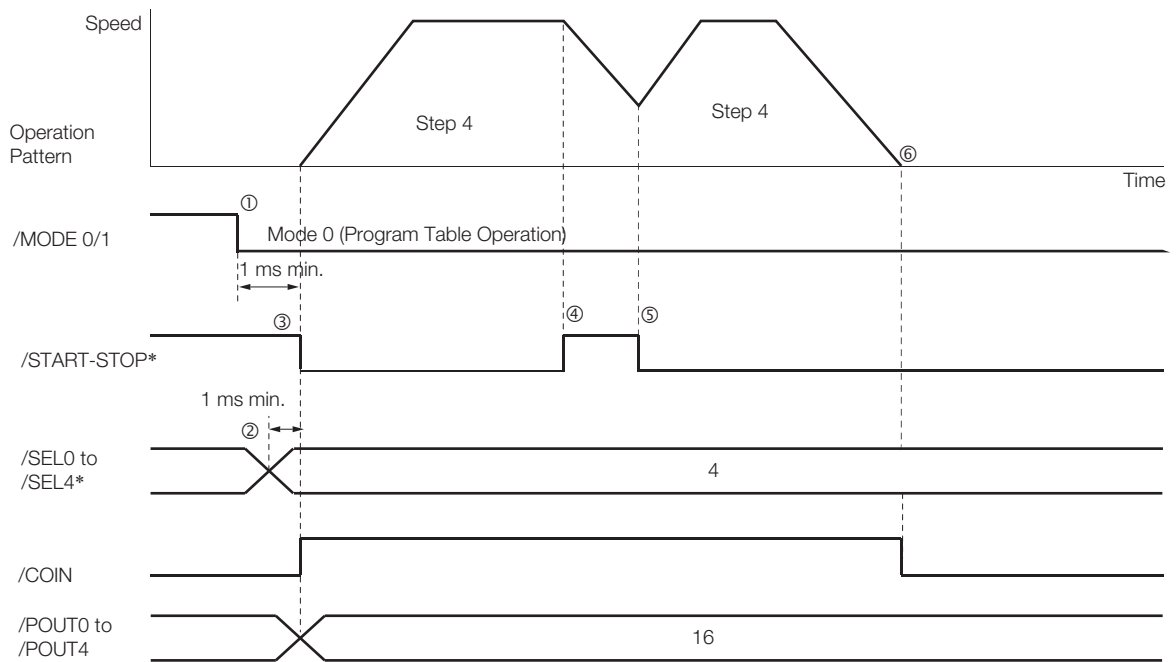

* Do not change /SEL0 to /SEL7 for 4 ms after turning ON the /START-STOP signal.

Outputting POUT Signals for the Specified Time

This example shows how to output the POUT signals in the next step for the specified length of time after completing positioning for a program step.

Positioning is registered for steps 0, 2, and 4. POUT signal outputs are specified for steps 1, 3, and 5.

The program table for this positioning is shown below.

PGM-STEP	POS	SPD	RDST	RSPD	ACC	DEC	POUT	EVENT	LOOP	NEXT
0	I+200000	15000	-	1000	400000	200000	NNNNN	IT0	1	1
1	-	15000	-	1000	:	:	::: A	T2000	1	2
2	I-200000	30000	-	1000	:	:	NNNNN	IT0	1	3
3	-	30000	-	1000	:	:	::: A :	T2000	1	4
4	I-200000	30000	-	1000	:	:	NNNNN	IT0	1	5
5	-	30000	-	1000	:	:	::: A ::	T2000	1	0

• Operating Procedure

- ① Turn ON the /MODE 0/1 signal to change to mode 0.
- ② Set the /SEL0 to /SEL4 signals to 0 to specify program step 0.
- ③ Turn ON the /START-STOP signal to start program table operation.
The /COIN signal turns OFF.
- ④ When positioning is completed to the target position, the /COIN signal turns ON.
Execution moves to program step 1 and the /POUT0 signal turns ON.
- ⑤ After a wait time of 2 seconds, execution of the program step specified with the NEXT setting (program step 2) is executed.
The /COIN signal turns OFF.
- ⑥ When positioning is completed to the target position, the /COIN signal turns ON.
Execution moves to program step 3 and the /POUT1 signal turns ON.
- ⑦ After a wait time of 2 seconds, execution of the program step specified with the NEXT setting (program step 4) is executed.
The /COIN signal turns OFF.
- ⑧ When positioning is completed to the target position, the /COIN signal turns ON.
Execution moves to program step 5 and the /POUT2 signal turns ON.
- ⑨ After a wait time of 2 seconds, execution of the program step specified with the NEXT setting (program step 0) is executed.
The /COIN signal turns OFF.
- ⑩ Steps 4 to 9 are repeated.

• Operation Pattern and Related Signal Timing

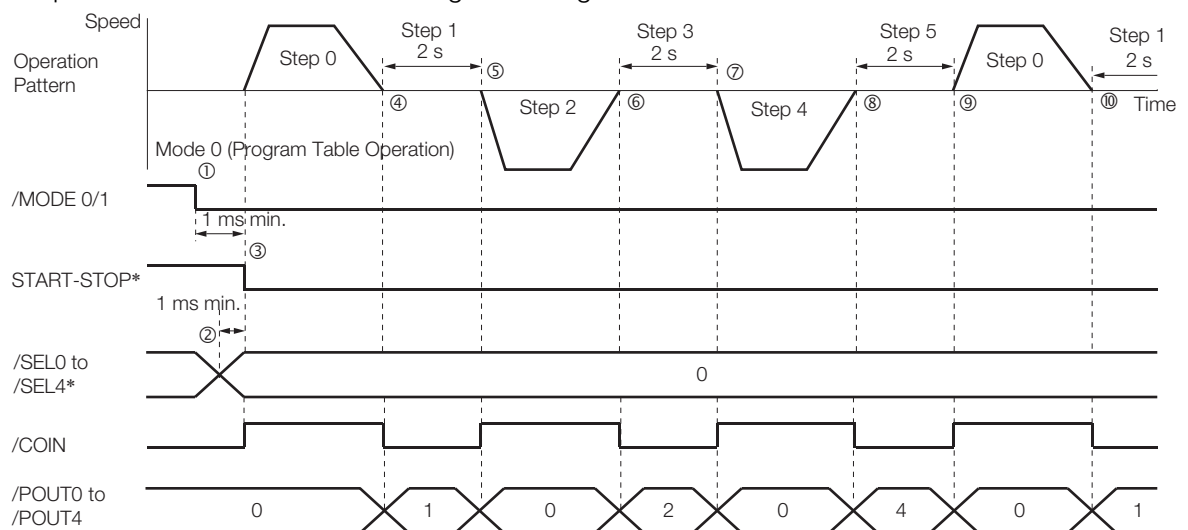

* Do not change /SEL0 to /SEL7 for 4 ms after turning ON the /START-STOP signal.

Specifying SEL Signals as Events

In this example, SEL signals are specified as the end conditions for the program steps. Step 0 ends 2 seconds after the /SEL0 signal turns ON after positioning is completed. Step 1 ends 2 seconds after the /SEL1 signal turns ON after positioning is completed. The program table for this positioning is shown below.

PGM-STEP	POS	SPD	RDST	RSPD	ACC	DEC	POUT	EVENT	LOOP	NEXT
0	I+200000	15000	-	1000	400000	200000	NNNNA	SEL0T2000	1	1
1	I-200000	30000	-	1000	400000	200000	NNNAN	SEL1T2000	2	0

• Operating Procedure

- ① Turn ON the /MODE 0/1 signal to change to mode 0.
- ② Set the /SEL0 to /SEL4 signals to 0 to specify program step 0.
- ③ Turn ON the /START-STOP signal to start program table operation.
The /COIN signal turns OFF and the /POUT0 signal turns ON.
- ④ When positioning is completed to the target position, the /COIN signal turns ON.
- ⑤ The /SEL0 signal turns ON.
- ⑥ After a wait time of 2 seconds, execution of the program step specified with the NEXT setting (program step 1) is executed.
The /COIN signal turns OFF and the /POUT1 signal turns ON.
- ⑦ When positioning is completed to the target position, the /COIN signal turns ON.
- ⑧ The /SEL1 signal turns ON.
- ⑨ After a wait time of 2 seconds, program step 1 is executed again.
The /COIN signal turns OFF.
- ⑩ When positioning is completed to the target position, the /COIN signal turns ON.
- ⑪ The /SEL1 signal turns ON.
- ⑫ After a wait time of 2 seconds, execution of the program step specified with the NEXT setting (program step 0) is executed.
The /COIN and /POUT1 signals turn OFF and the /POUT0 signal turns ON.
- ⑬ Steps 4 to 12 are repeated.

• Operation Pattern and Related Signal Timing

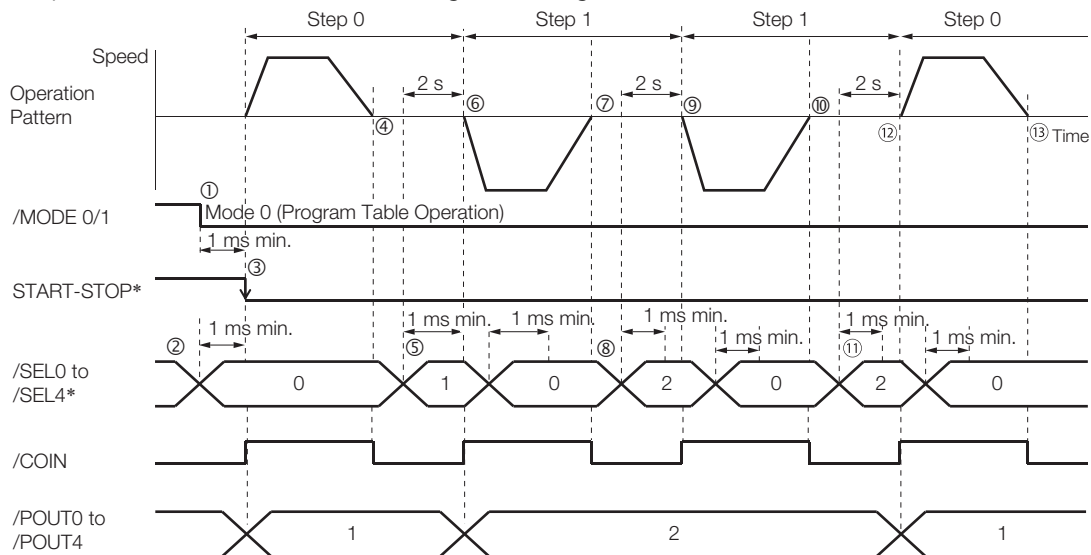

* Do not change /SEL0 to /SEL7 for 4 ms after turning ON the /START-STOP signal.

Combining Positioning with Constant-Speed Operation

This example shows how to perform operation that combines constant-speed operation and positioning when the target position (POS) is set to INFINITE.

Step 0 performs operation for 2 seconds with no target position (infinite length = INFINITE) at a speed of 15,000,000 reference units/min.

Step 1 performs operation with no target position (infinite length = INFINITE) and changes the speed from 15,000,000 reference units/min to 30,000,000 reference units/min. Operation continues until the /SEL0 signal turns ON.

Step 2 decelerates the motor to a stop and step 3 performs relative positioning from the stop position to a target position of 200,000 reference units.

PGM-STEP	POS	SPD	RDST	RSPD	ACC	DEC	POUT	EVENT	LOOP	NEXT
0	+INFINITE	15000	-	1000	400000	200000	NNNNN	T2000	1	1
1	+INFINITE	30000	-	1000	:	:	:	SELOT0	1	2
2	STOP	30000	-	1000	:	:	:	IT0	1	3
3	I+200000	30000	-	1000	:	:	:	SEL1T0	1	0

• Operating Procedure

- ① Turn ON the /MODE 0/1 signal to change to mode 0.
- ② Set the /SEL0 to /SEL4 signals to 0 to specify program step 0.
- ③ Turn ON the /START-STOP signal to start program table operation.
The /COIN signal turns OFF.
- ④ After 2 seconds elapse, step 1 is executed.
- ⑤ When the /SEL0 signal turns ON, step 2 is executed.
- ⑥ After the motor decelerates to a stop, the /COIN signal turns ON and step 3 is executed.
At the start of execution, the /COIN signal turns OFF.
- ⑦ When positioning is completed to the target position, the /COIN signal turns ON.
- ⑧ When the /SEL1 signal turns ON, program step 3 is ended and program step 0 is executed.

• Operation Pattern and Related Signal Timing

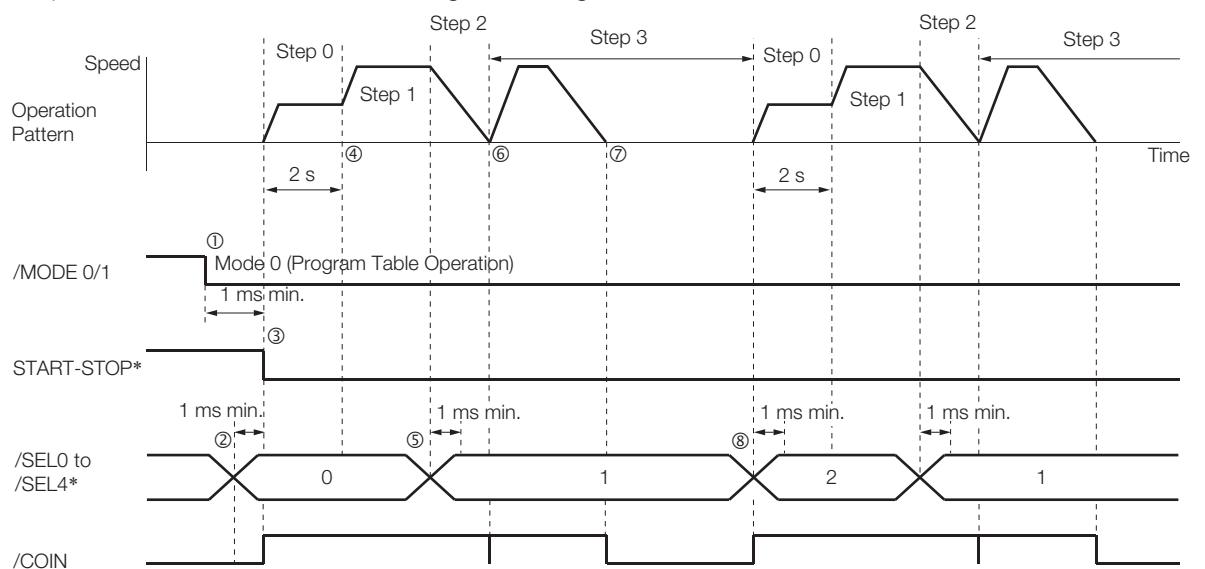

* Do not change /SEL0 to /SEL7 for 4 ms after turning ON the /START-STOP signal.

Performing Registration

This example shows how to use the /RGRT signal during execution of a program step to change to the specified speed and perform positioning for the specified distance.

Step 0 performs positioning for a travel distance (RDST) of 100,000 reference units when the /RGRT signal turns ON.

The speed changes to 15,000,000 reference units/min (RSPD).

Step 1 performs positioning for a travel distance (RDST) of 100,000 reference units when the /RGRT signal turns ON.

The speed changes to 15,000,000 reference units/min (RSPD).

The program table for this positioning is shown below.

PGM-STEP	POS	SPD	RDST	RSPD	ACC	DEC	POUT	EVENT	LOOP	NEXT
0	I+200000	30000	100000	15000	400000	200000	NNNNNNNN	ITO	1	1
1	I-200000	30000	100000	15000	:	:	:::~::~:	ITO	1	0

• Operating Procedure

- ① Turn ON the /MODE 0/1 signal to change to mode 0.
- ② Set the /SEL0 to /SEL4 signals to 0 to specify program step 0.
- ③ Turn ON the /START-STOP signal to start program table operation.
The /COIN signal turns OFF.
- ④ The /RGRT signal turns ON to perform registration operation.
The speed changes to the registration speed.
- ⑤ The /COIN turns ON when positioning is completed for the registration distance.
- ⑥ When execution of program step 1 starts, the /COIN signal turns OFF.

• Operation Pattern and Related Signal Timing

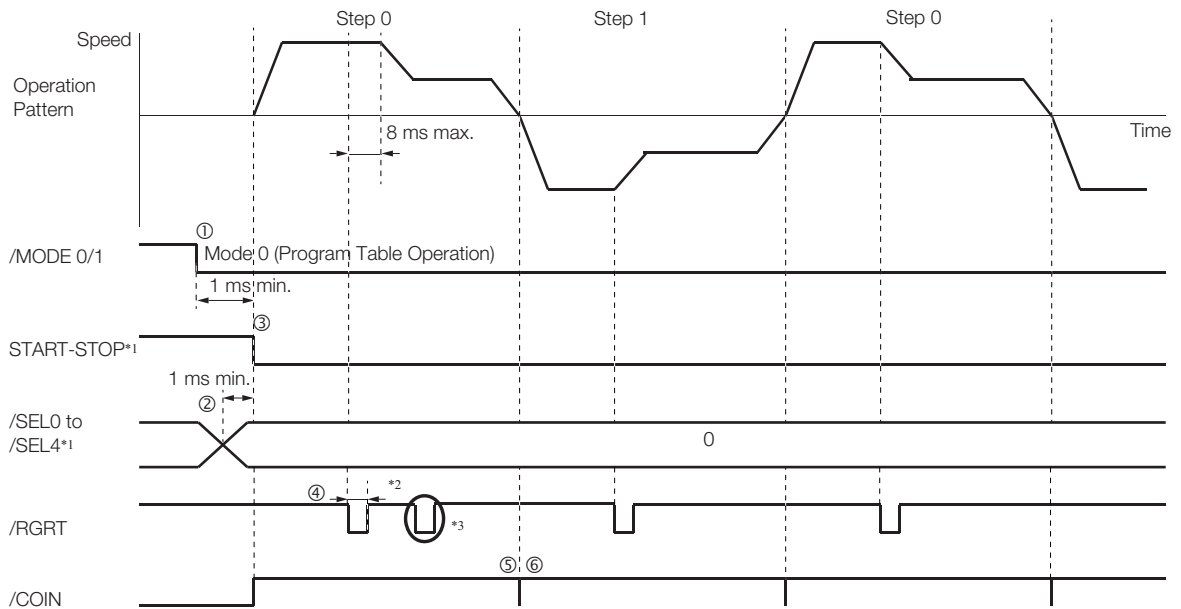

*1. Do not change /SEL0 to /SEL7 for 4 ms after turning ON the /START-STOP signal.

*2. Pn635 = n.□□□0 (Registration is started by changing the input signal from OFF (open) to ON (closed)): 20 μs min.
 Pn635 = n.□□□1 (Registration is started by changing the input signal from ON (closed) to OFF (open)): 200 μs min.

*3. The /RGRT signal is ignored during registration operation.

Pausing Registration

This example shows how to turn OFF the /START-STOP signal to temporarily stop registration operation and then turn ON the /START-STOP signal to restart registration operation.

The program table for this positioning is shown below.

PGM-STEP	POS	SPD	RDST	RSPD	ACC	DEC	POUT	EVENT	LOOP	NEXT
0	I+200000	30000	100000	15000	400000	200000	NNNNNNNN	ITO	1	1
1	I-200000	30000	100000	15000	:	:	:::~::~:	ITO	1	END

• Operating Procedure

- ① Turn ON the /MODE 0/1 signal to change to mode 0.
- ② Set the /SEL0 to /SEL4 signals to 0 to specify program step 0.
- ③ Turn ON the /START-STOP signal to start program table operation.
The /COIN signal turns OFF.
- ④ The /RGRT signal turns ON to perform registration operation.
The speed changes to the registration speed.
- ⑤ Turn OFF the /START-STOP signal to stop operation.
- ⑥ Turn ON the /START-STOP signal to restart program table operation.
- ⑦ The /COIN turns ON when positioning is completed for the remaining registration distance.
- ⑧ When execution of program step 1 starts, the /COIN signal turns OFF.
- ⑨ The /RGRT signal turns ON to perform registration operation.
The speed changes to the registration speed.
- ⑩ The /COIN turns ON when positioning is completed for the registration distance.

• Operation Pattern and Related Signal Timing

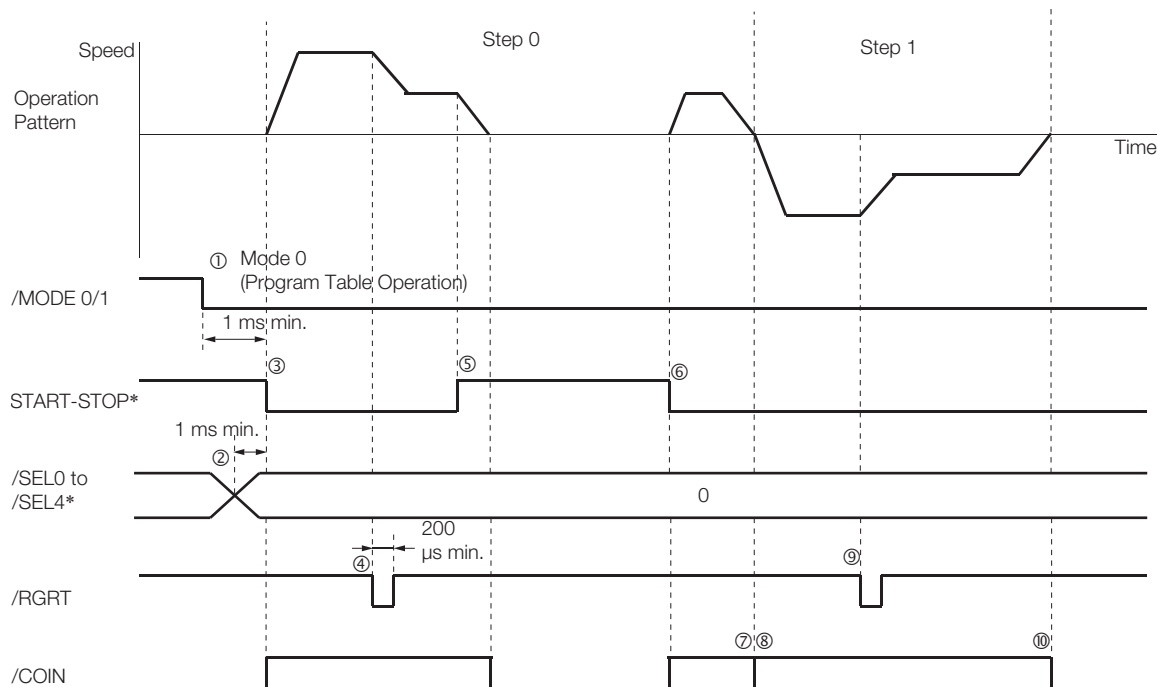

* Do not change /SEL0 to /SEL7 for 4 ms after turning ON the /START-STOP signal.

Turning ON the /RGRT Signal While Program Table Operation Is Stopped

This example shows what happens when the /RGRT signal is turned ON while program table operation is stopped after turning OFF the /START-STOP signal. In this case, registration operation is performed when the /START-STOP signal is turned ON.

The program table for this positioning is shown below.

PGM-STEP	POS	SPD	RDST	RSPD	ACC	DEC	POUT	EVENT	LOOP	NEXT
0	I+200000	30000	100000	15000	400000	200000	NNNNNNNN	IT0	1	1
1	I-200000	30000	100000	15000	:	:	:::~::~:	IT0	1	END

• Operating Procedure

- ① Turn ON the /MODE 0/1 signal to change to mode 0.
- ② Set the /SEL0 to /SEL4 signals to 0 to specify program step 0.
- ③ Turn ON the /START-STOP signal to start program table operation.
The /COIN signal turns OFF.
- ④ Turn OFF the /START-STOP signal to stop operation.
- ⑤ The /RGRT signal turns ON to specify registration operation.
- ⑥ Turn ON the /START-STOP signal to restart program table operation.
In this case, registration operation is performed.
- ⑦ The /COIN turns ON when positioning is completed for the registration distance.
- ⑧ When execution of program step 1 starts, the /COIN signal turns OFF.
- ⑨ The /RGRT signal turns ON to perform registration operation.
The speed changes to the registration speed.
- ⑩ The /COIN turns ON when positioning is completed for the registration distance.

• Operation Pattern and Related Signal Timing

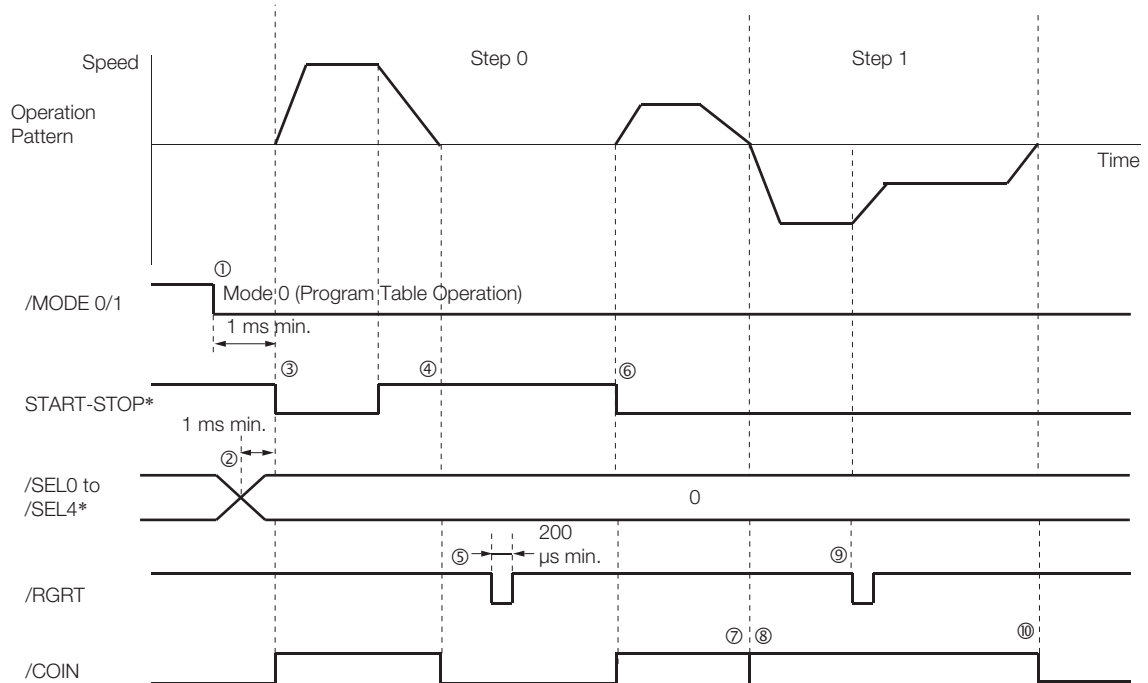

* Do not change /SEL0 to /SEL7 for 4 ms after turning ON the /START-STOP signal.

Using Consecutive Stops



Term

You can use consecutive stops to set the target position to infinite (+/-INFINITE) and then perform positioning from constant-speed operation to a specified absolute position within the rotational coordinates without stopping.

During positioning, the positioning speed (SPD) that is set for the previous program step is continued until the point where deceleration is started to position to the target position within the rotational coordinates without rotating in the reverse direction.

Note: Conditions for Using a Consecutive Stop

All of the following conditions must be met to use a consecutive stop.

If execution is attempted when any of the conditions is not met, an E53E (Movement Reference Duplication) or E63E (Consecutive Stop Execution Failure) error will occur.

Conditions:

- Rotational coordinates must be used (Pn637 ≠ n.□□□0).
- The target position (POS) in the previous program step must be infinite (±INFINITE).
- Registration cannot be used in the previous program step.

A consecutive stop is used with a program step that is set for an infinite length and constant-speed operation.

In the following example, step 0 operates the motor for 2 seconds at a speed of 1,080,000,000 reference units/min and then execution moves to step 1. If the reference unit is set to 0.001 deg, then the speed would be 1,080 deg/min.

Step 1 continues operation at the positioning speed (SPD) specified for step 0 and performs positioning to a target position of 45,000 reference units (45 deg). The rotation direction is not reversed.

The program table for this positioning is shown below.

PGMSTEP	POS	SPD	RDST	RSPD	ACC	DEC	POUT	EVENT	LOOP	NEXT
0	+INFINITE	1080000	-	1000	1080	1080	NNNNNNNA	T2000	1	1
1	S+45000	1000	-	1000	1080	1080	NNNNNNAN	IT0	1	END

Note: 1. If INFINITE is specified for the target position (POS), always set the number of loops setting (LOOP) to 1.

2. If a consecutive stop is specified for the target position (POS), the settings of the positioning speed (SPD) and acceleration rate (ACC) are ignored. The values that were specified in the previous program step are used.

• Operating Procedure

- ① Turn ON the /MODE 0/1 signal to change to mode 0.
- ② Set the /SEL0 to /SEL4 signals to 0 to specify program step 0.
- ③ Turn ON the /START-STOP signal to start program table operation.
The /COIN signal turns OFF and the /POUT0 signal turns ON.
- ④ After 2 seconds elapse, step 1 is executed.
The /POUT0 signal turns OFF and the /POUT1 signal turns ON.
- ⑤ When positioning is completed to the target position (45 deg = 45,000 reference units), the /COIN signal turns ON.

7.3 Program Table Operation

7.3.7 Program Table Operation Examples

- Operation Pattern and Related Signal Timing

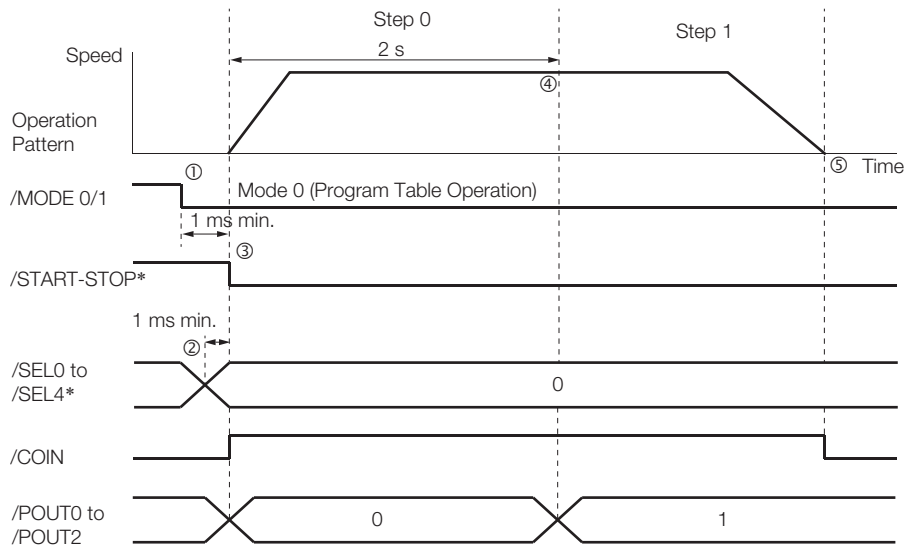

* Do not change /SEL0 to /SEL7 for 4 ms after turning ON the /START-STOP signal.

Resetting Program Table Operation

In this example, program operation is reset during repeated operation of program steps 0 and 1 and then the program step is specified and operation is restarted from the canceled state.

Note: "Canceled" is the state in which the mode is mode 0, execution is not in a stopped state, and no program step has been executed.

Step 0 performs relative positioning for 100,000 reference units at a speed of 15,000,000 reference units/min. The acceleration rate is 400,000,000 reference units/min/ms and the deceleration rate is 200,000,000 reference units/min/ms.

Step 1 performs relative positioning for 100,000 reference units at a speed of 30,000,000 reference units/min. The acceleration rate is 400,000,000 reference units/min/ms and the deceleration rate is 200,000,000 reference units/min/ms.

The program table for this positioning is shown below.

PGM-STEP	POS	SPD	RDST	RSPD	ACC	DEC	POUT	EVENT	LOOP	NEXT
0	I+100000	15000	-	1000	400000	200000	NNNNN- NNN	IT1000	1	1
1	I-100000	30000	-	1000	400000	200000	NNNNN- NNN	IT1000	1	0

• Operating Procedure

- ① Turn ON the /MODE 0/1 signal to change to mode 0.
- ② Set the /SEL0 to /SEL4 signals to 0 to specify program step 0.
- ③ Turn ON the /START-STOP signal to start program table operation.
- ④ Turn OFF the /START-STOP signal to stop program table operation.
- ⑤ Turn ON the /PGMRES signal to cancel program table operation.
- ⑥ Set the /SEL0 to /SEL4 signals to 1 (i.e., turn ON /SEL0) to specify program step 1.
- ⑦ Turn ON the /START-STOP signal to start program table operation.
- ⑧ When positioning is completed to the target position, the /COIN signal turns ON.

• Operation Pattern and Related Signal Timing

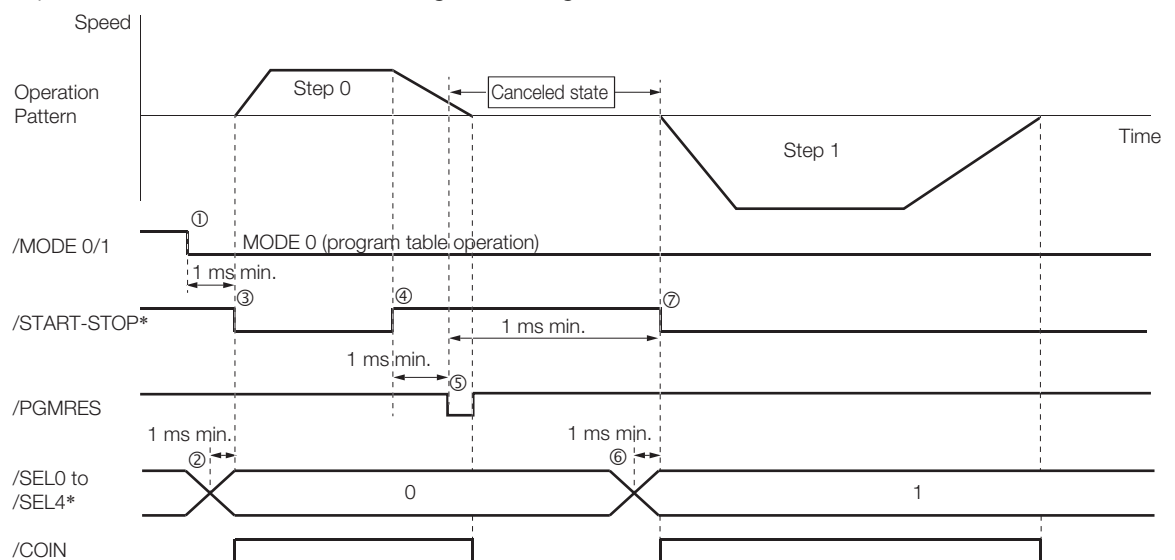

* Do not change /SEL0 to /SEL7 for 4 ms after turning ON the /START-STOP signal.

7.3.8 EVENT Examples

This section provides examples of the settings and operations for the EVENT end conditions for program steps.

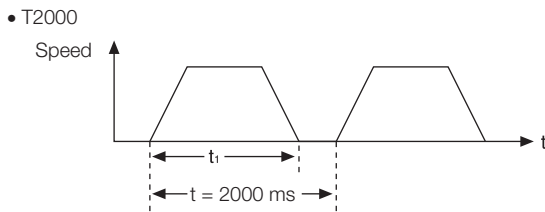
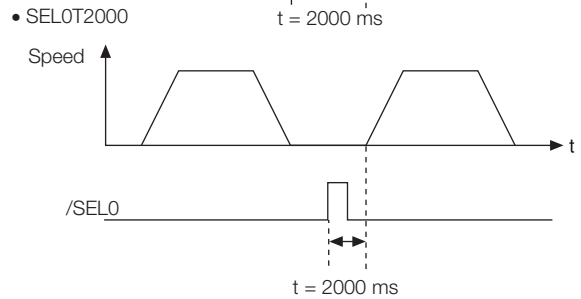
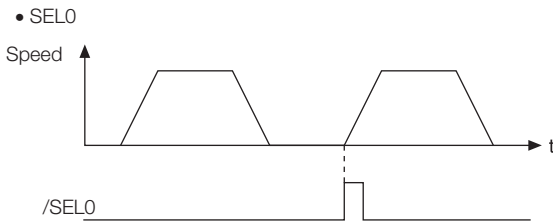
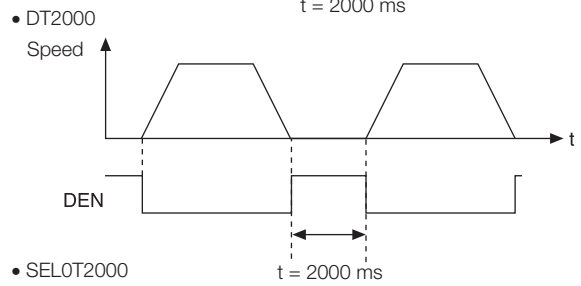
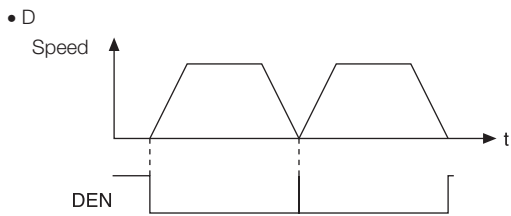
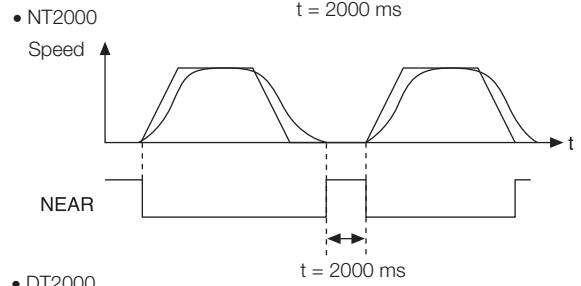
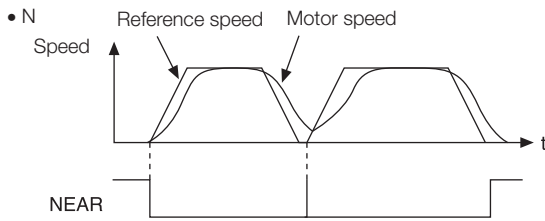
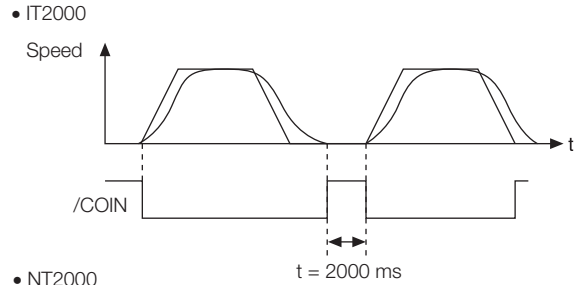
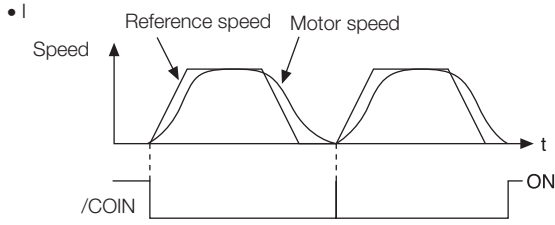

Note: If $t < t_1$, an error (E53E) will occur and program table operation will be stopped.

7.3.9 Output Response Times after /START-STOP Turns ON

The response times for starting the motor, the /COIN signal, and the /POUT0 to /POUT4 signals when the /START-STOP signal is turned ON to start program table operation are shown below.

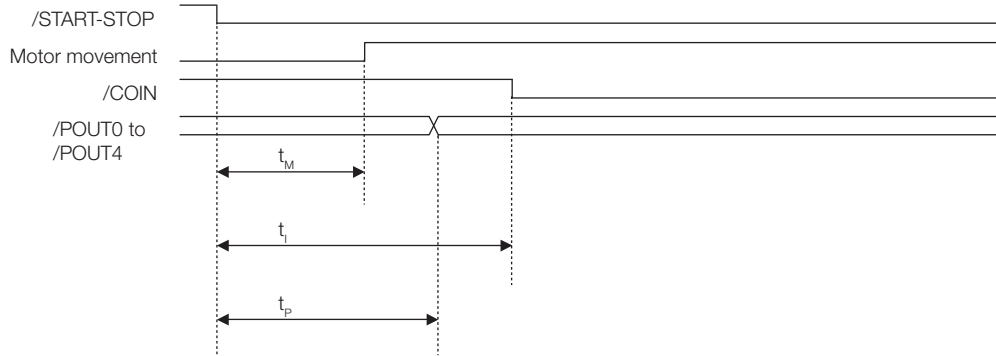

Response Times	
t_M	1 ms max.
t_I	1 ms max.
t_P	1 ms max.

7.4 Jog Speed Table Operation

You can perform jog operation from the SigmaWin+, or you can use the /JOGP and /JOGN input signals to perform jog operation. Jog operation is performed at the specified jog speed.

7.4.1 Input Signals Related to Jog Operation

The following signals are used for jog operation: /MODE 0/1, /JOGP, /JOGN, and /JOG0 to /JOG2.

Turn OFF the /MODE 0/1 signal to change to mode 1. Use the /JOGP signal as the command for forward jog operation and the /JOGN signal as the command for reverse jog operation.

Input Signal	Description	Reference
/MODE 0/1	ON: Mode 0 (program table operation) OFF: Mode 1 (jog speed table operation or homing)	page 6-3
/JOGP	Turn this signal ON to jog forward at the jog speed registered in the jog speed table. The motor is accelerated according to Pn63E (Acceleration Rate). When this signal turns OFF, the motor is decelerated to a stop according to Pn640 (Deceleration Rate).	page 6-3
/JOGN	Turn this signal ON to jog in reverse at the jog speed registered in the jog speed table. The motor is accelerated according to Pn63E (Acceleration Rate). When this signal turns OFF, the motor is decelerated to a stop according to Pn640 (Deceleration Rate).	page 6-3
/JOG0 to /JOG2	Use these signals to specify a jog speed that is registered in the jog speed table.	page 6-3



Turn ON only one of the following signals at the same time: /HOME, /JOGP, and /JOGN. Otherwise, the command will be disabled and no operation will be performed. To jog the motor, turn ON either the /JOGP or /JOGN signal.

Note

7.4.2 Jog Speeds

You set the jog speeds in the Jog Speed Table Editing Dialog Box on the SigmaWin+. You can register up to eight jog speeds in JSPD0 to JSPD7 in the jog speed table.

The specifications for the jog speeds are given in the following table.

Jog Speed	Setting Range	Setting Unit	Default Setting	When Enabled
	1 to 199,999,999	1,000 reference units/min	1,000	Immediately

Note: Edit the jog speed table only when the Servomotor is stopped.

7.4.3 Jog Speed Table and Speed Selection Signals

You can register up to eight jog speeds in the jog speed table.

The /JOG0 to /JOG2 (Jog Speed Selection) signals are used to specify the jog speeds that are registered in the jog speed table.

Jog Speed Table		Jog Speed Selection Signals		
JSPD	Jog Speed (1,000 reference units/min)	/JSPD2	/JSPD1	/JSPD0
0	±nnnnnnnnn	0	0	0
1	±nnnnnnnnn	0	0	1
2	±nnnnnnnnn	0	1	0
3	±nnnnnnnnn	0	1	1
4	±nnnnnnnnn	1	0	0
5	±nnnnnnnnn	1	0	1
6	±nnnnnnnnn	1	1	0
7	±nnnnnnnnn	1	1	1

Note: 1: Signal is ON (active), 0: Signal is OFF (inactive).

7.4.4 SigmaWin+ Procedures

You use the SigmaWin+ to edit, write, and save the jog speed table.

Use the following flow.

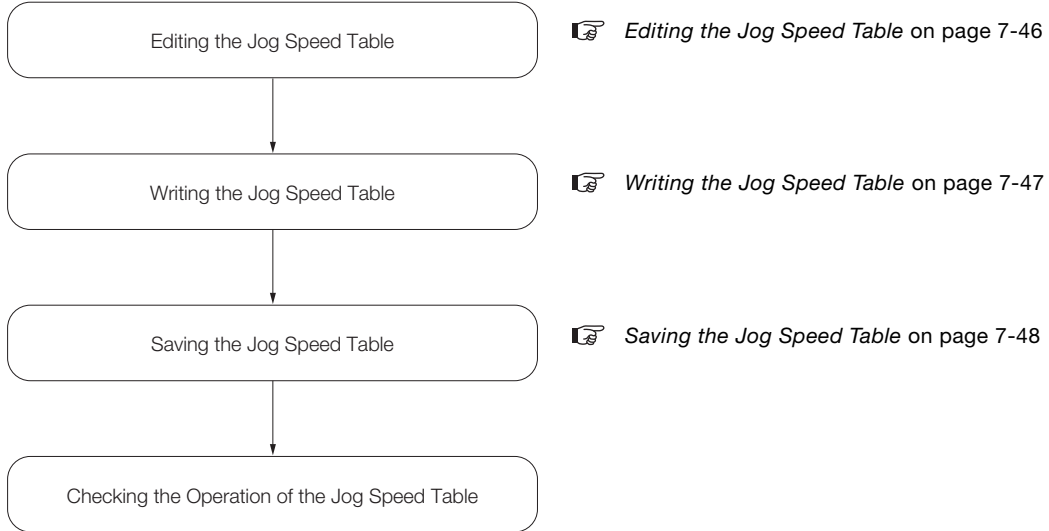

Editing the Jog Speed Table

◆ Displaying the Jog Speed Table Editing Dialog Box

Select **Edit Jog Speed Table** from the menu bar of the Main Window of the SigmaWin+.

◆ Details on the Jog Speed Table Editing Dialog Box

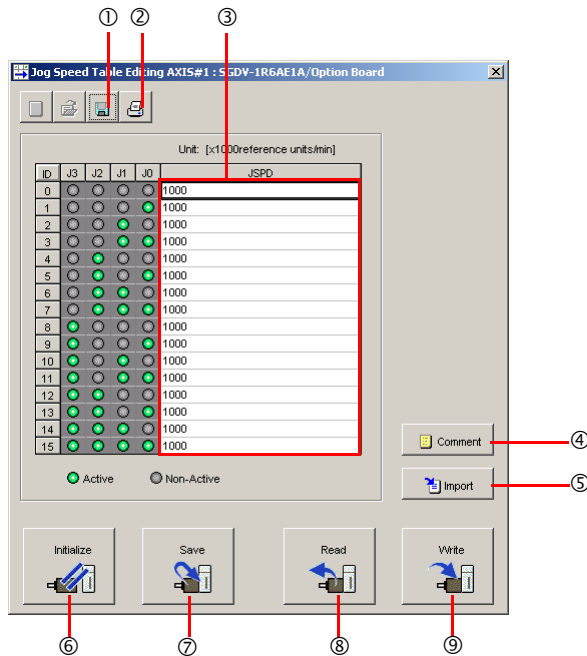

No.	Item	Description
①	Save Button	Saves the currently displayed settings to a computer file.
②	Print Button	Prints the currently displayed settings.
③	Setting Area	Set the jog speeds. Select the cell and enter the value directly.

Continued on next page.

Continued from previous page.

No.	Item	Description
④	Comment Button	Lets you add a comment.
⑤	Import Button	Imports a jog speed table from a file saved on the computer to the SigmaWin+.
⑥	Initialize Button	Initializes the flash memory in the SERVOPACK.
⑦	Save Button	Saves the settings in the SERVOPACK to flash memory.
⑧	Read Button	Reads the settings in the SERVOPACK to the SigmaWin+.
⑨	Write Button	Writes the currently displayed settings to the SERVOPACK.

Writing the Jog Speed Table

You can write the edited jog speed table to SERVOPACK RAM to operate the SERVOPACK according to the program.



Note

1. Make sure that the system is in SERVO OFF state when you write the jog speed table.
2. The jog speed table that is written will be deleted when the power supply to the SERVOPACK is turned OFF. Before you turn OFF the power supply to the SERVOPACK, save the jog speed table from RAM to flash memory. Refer to the following section for the operating procedure.

Saving the Jog Speed Table on page 7-48

1. Click the Write Button on the Jog Speed Table Editing Dialog Box.

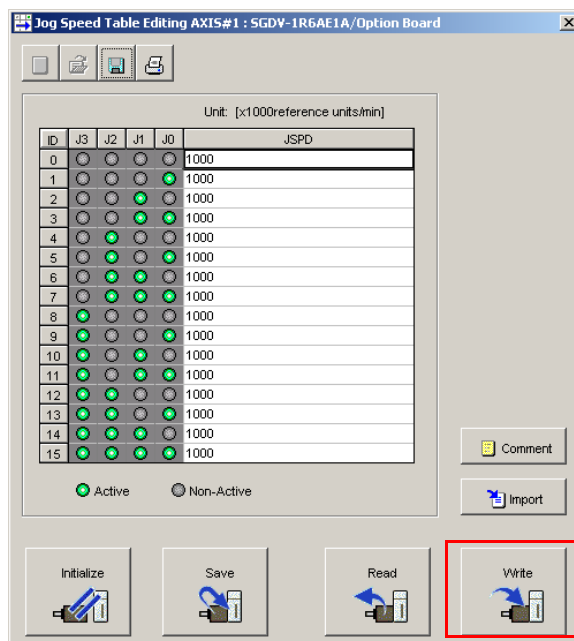

The Write Dialog Box will be displayed.

2. Click the OK Button.



The jog speed table edited on the SigmaWin+ will be written to the SERVOPACK and the edited cells will change to white.

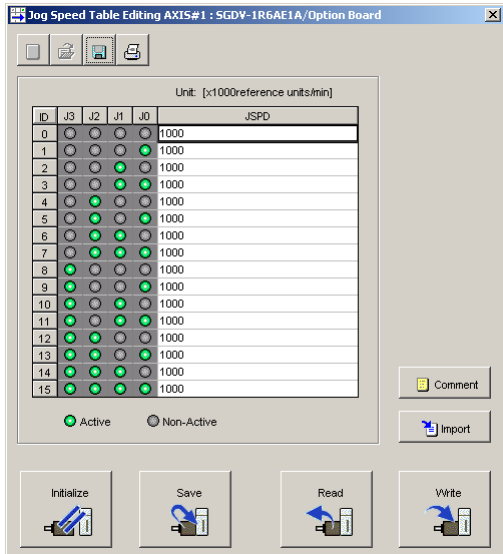

This concludes the writing procedure.

Saving the Jog Speed Table

◆ Saving the Jog Speed Table to Flash Memory in the SERVOPACK

To prevent the jog speed table from being deleted when the power supply to the SERVOPACK is turned OFF, you must save it to flash memory in the SERVOPACK. The jog speed table that is saved in the flash memory is automatically loaded each time the power supply is turned ON.

There are the following two ways to save the jog speed table to flash memory in the SERVOPACK.

- Save it from the Jog Speed Table Editing Dialog Box.
- Save it with Fn060 (Edit/Save Jog Speed Table) on a Digital Operator.

Use the following procedure to save the jog speed table from the Jog Speed Editing Dialog Box.

1. Click the **Save** Button on the Jog Speed Table Editing Dialog Box.

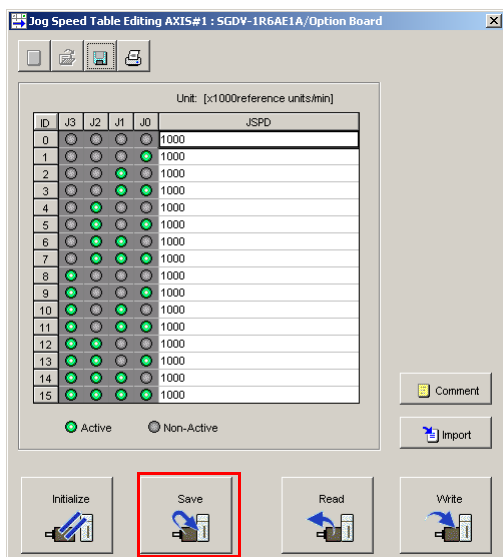

The Save Table Dialog Box will be displayed.

2. Click the OK Button.

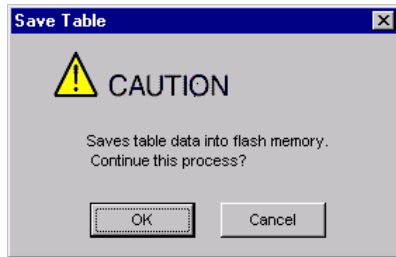

This concludes the saving procedure.

◆ Saving the Jog Speed Table to a Computer File

You can save the jog speed table to a file on the computer. Use computer files to back up jog speed tables.

1. Click the Save Button.

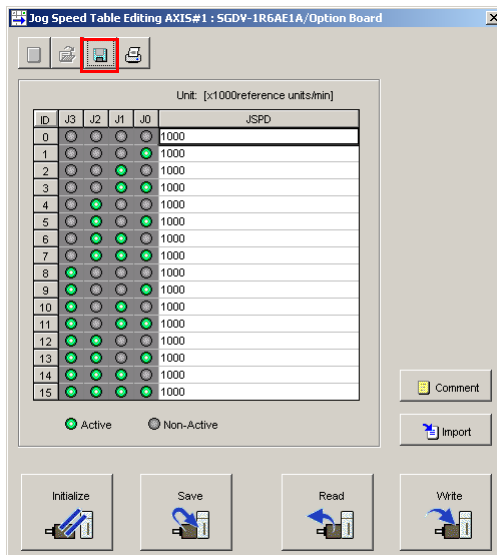

The Save As Dialog Box will be displayed.

2. Specify the save location and file name.

You can set any file name. However, you cannot change the file name extension.

Information You can also set a comment.

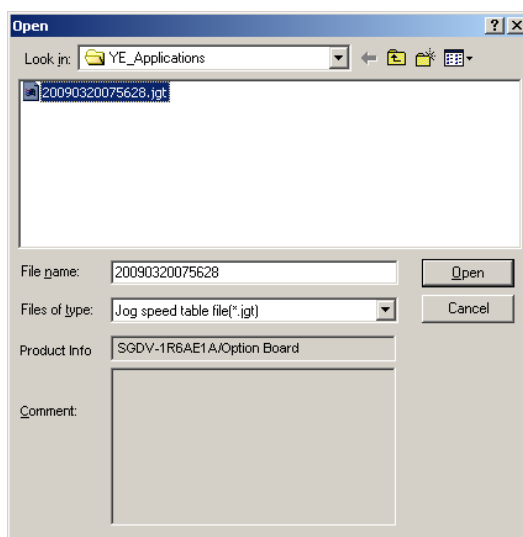

7.4 Jog Speed Table Operation

7.4.4 SigmaWin+ Procedures

Information You can use the **Import** Button to load the jog speed table saved in a file to the SERVO-PACK.

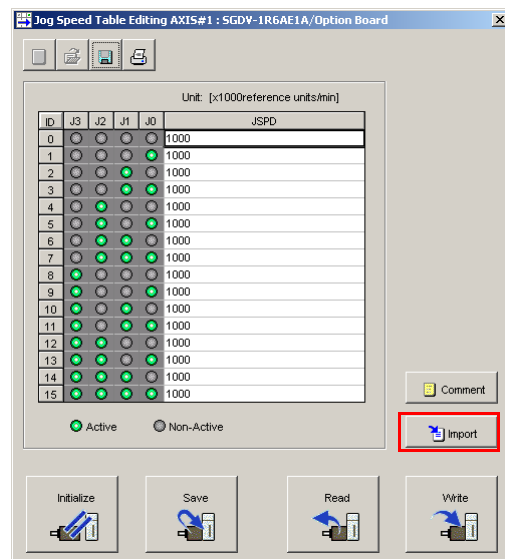

This concludes the saving procedure.

7.4.5 Jog Speed Table Operation Example

This example shows how to perform operation by using the /JOG0 to /JOG2 (Jog Speed Selection) signals to specify the jog speeds that are registered in the jog speed table.

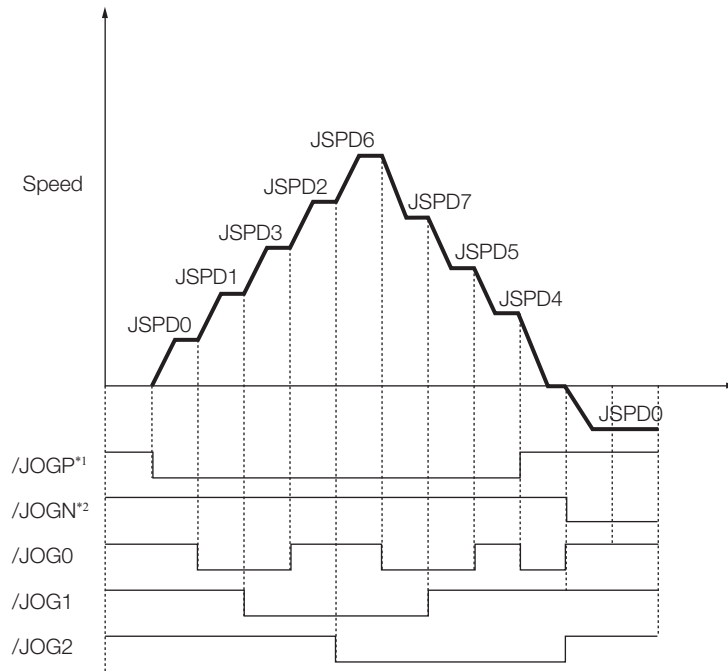

*1. Forward operation at the jog speed is performed while the /JOGP signal is ON.

*2. Reverse operation at the jog speed is performed while the /JOGN signal is ON.

7.4.6 Timing of Signal Changes

The timing of the /MODE 0/1 and /JOGP signals, the /MODE 0/1 and /JOGN signals, and the /HOME, /JOGP, and /JOGN signals is shown below.

To start jog operation, turn OFF the /MODE 0/1 signal, wait for at least 1 ms, and then turn ON the /JOGP or /JOGN signal.

To change to mode 0, turn OFF the /JOGP or /JOGN signal and then turn OFF the /MODE 0/1 signal. The timing is shown below.

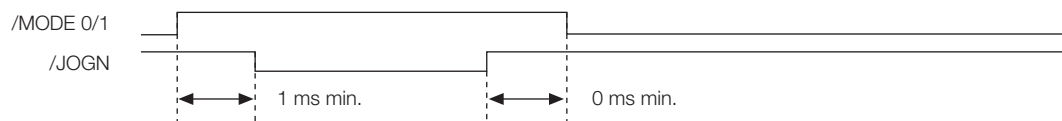
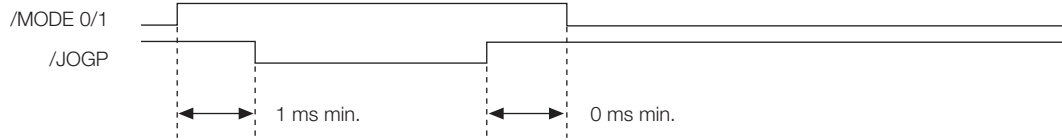

If you have performed homing, turn OFF the /HOME signal, wait for at least 1 ms, and then turn ON the /JOGP or /JOGN signal. When performing jog operation in both directions, allow at least 1 ms between the /JOGP and /JOGN signals. The timing is shown below.

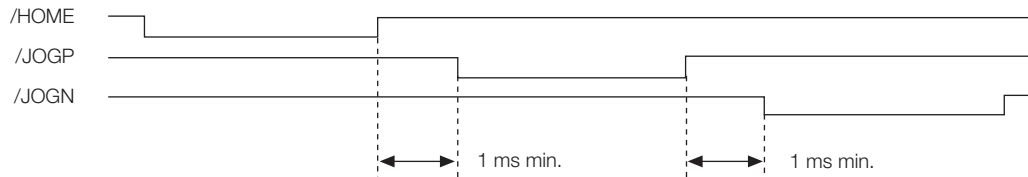

7.5 ZONE Outputs

You can use ZONE signals to output a ZONE number to indicate when the current value is within a registered zone.

The ZONE signals (/Z0 to /Z2) are assigned to output signals /POUT0 to /POUT2 on CN1.

7.5.1 ZONE Table and ZONE Signals

You can register the desired zones in the ZONE table. The ZONE table consists of settings for the ZONE numbers (ZONE), ZONE N values (ZONE N), and ZONE P values (ZONE P). You can register up to eight zones.

The ZONE numbers identify the registered zones.

ZONE N is the lower limit of the ZONE and ZONE P is the upper limit of the ZONE. The setting conditions for ZONE N and ZONE P are given in the following table.

Setting Range	Setting Unit	Default Setting	When Enabled
-1073741823 to +1073741823	Reference units	0	Immediately

The ZONE signals indicate the ZONE number. If the current value is within a zone registered in the ZONE table, the corresponding ZONE number is output on the ZONE signals.

You can use the ZONE numbers as required, e.g., to trigger operations related to positioning.

ZONE Table			ZONE Signals		
ZONE Number (ID)	ZONE N [Reference Units]	ZONE P [Reference Units]	/Z2 (/POUT2)	/Z1 (/POUT1)	/Z0 (/POUT0)
0	±nnnnnnnnnn	±nnnnnnnnnn	0	0	0
1	±nnnnnnnnnn	±nnnnnnnnnn	0	0	1
2	±nnnnnnnnnn	±nnnnnnnnnn	0	1	0
3	±nnnnnnnnnn	±nnnnnnnnnn	0	1	1
4	±nnnnnnnnnn	±nnnnnnnnnn	1	0	0
5	±nnnnnnnnnn	±nnnnnnnnnn	1	0	1
6	±nnnnnnnnnn	±nnnnnnnnnn	1	1	0
7	±nnnnnnnnnn	±nnnnnnnnnn	1	1	1

Note: 1: Signal is ON (active), 0: Signal is OFF (inactive).



Note

Always save the ZONE table to flash memory after you edit it. Refer to the following section for the procedure.

 **◆ Saving the Program Table to Flash Memory in the SERVOPACK on page 7-24**

If you turn OFF the power supply before you save changes to flash memory, the changes to the ZONE table will be lost.

ZONE Table Settings and ZONE Numbers

The relationship between the ZONE table settings and the ZONE numbers is shown below.

- **ZONE N ≤ ZONE P**

The ZONE signals for the corresponding ZONE number is output if the current value is between ZONE N and ZONE P, inclusive (the shaded part in the following figure).



- **ZONE P ≤ ZONE N**

The ZONE signals for the corresponding ZONE number is output if the current value is less than or equal to ZONE P or greater than or equal to ZONE N (the shaded parts in the following figure).



- **Duplicated Settings in the ZONE Table**
The smaller ZONE number is output.
- **ZONE N and ZONE P = 0**
The ZONE number is disabled.
- **When the Current Value Is Not In Any ZONE**
All of the ZONE signals will be OFF (0).

7.5.2 Parameters Related to ZONE Signals

With the following parameter, the initial status* of the programmable output signals (/POUT0 to /POUT2) can be set to ZONE signals.

* The initial status is the status that exists after the control power supply is turned ON or after resetting the SERVOPACK.

Parameter	Meaning	When Enabled	Classification
Pn64C = n.□□□X	0 (default setting)	After restart	Setup
	1		

7.5.3 SigmaWin+ Procedures

You use the SigmaWin+ to edit, write, and save the ZONE table.
Use the following flow.

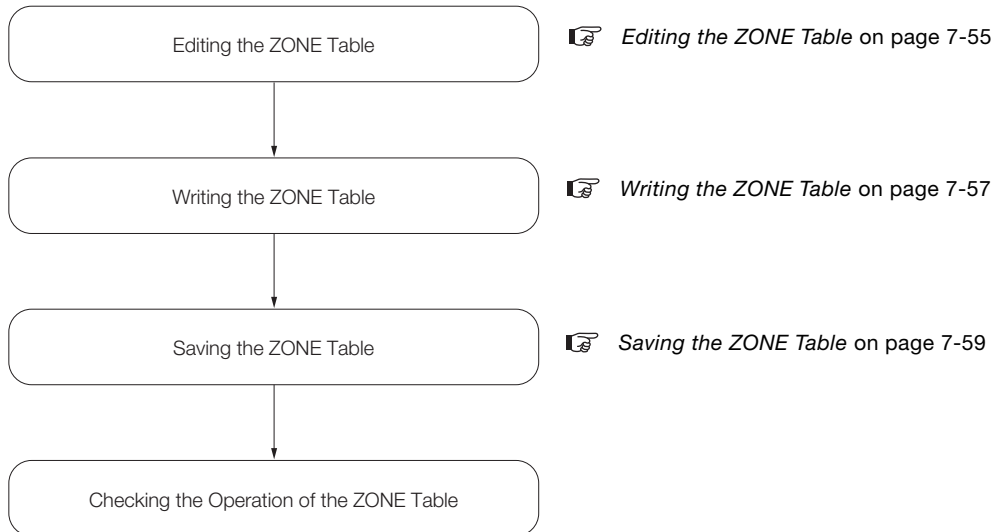

Editing the ZONE Table

- ◆ **Displaying the ZONE Table Editing Dialog Box.**
Select **Edit ZONE Table** from the menu bar of the Main Window of the SigmaWin+.
- ◆ **Details on the ZONE Table Editing Dialog Box**

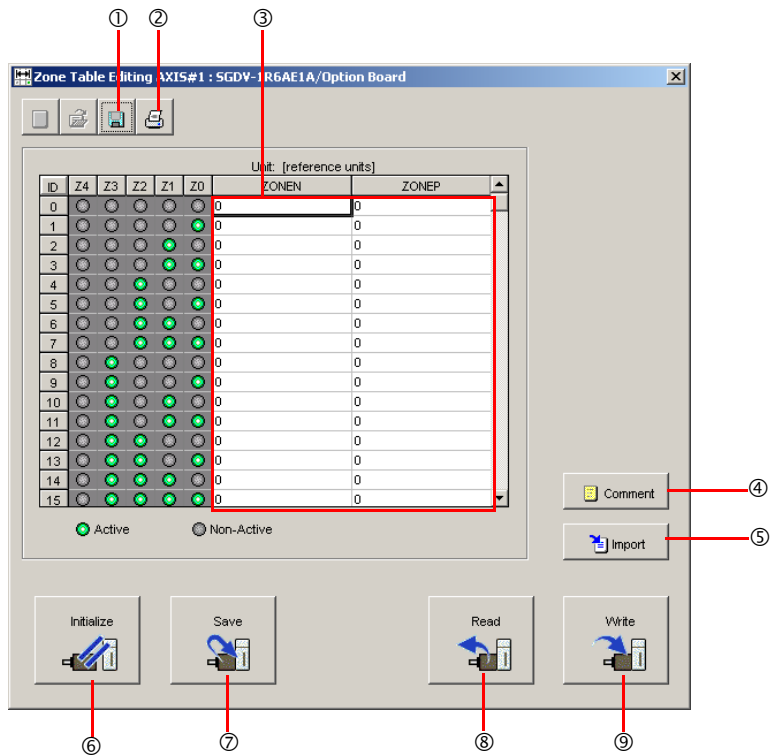

7.5 ZONE Outputs

7.5.3 SigmaWin+ Procedures

No.	Name	Description
①	Save Button	Saves the currently displayed settings to a computer file.
②	Print Button	Prints the currently displayed settings.
③	Setting Area	Sets the ranges for ZONE outputs. Select the cell and enter the value directly.
④	Comment Button	Lets you add a comment.
⑤	Import Button	Imports a ZONE table from a file saved on the computer to the SigmaWin+.
⑥	Initialize Button	Initializes the flash memory in the SERVOPACK.
⑦	Save Button	Saves the settings in the SERVOPACK to flash memory.
⑧	Read Button	Reads the settings in the SERVOPACK to the SigmaWin+.
⑨	Write Button	Writes the currently displayed settings to the SERVOPACK.

Writing the ZONE Table

You can write the edited ZONE table to SERVOPACK RAM to operate the SERVOPACK according to the program.



Note

1. Make sure that the system is in SERVO OFF state when you write the ZONE table.
2. The ZONE table that is written will be deleted when the power supply to the SERVOPACK is turned OFF. Before you turn OFF the power supply to the SERVOPACK, save the ZONE table from RAM to flash memory. Refer to the following section for the operating procedure.
Saving the ZONE Table on page 7-59

1. Click the **Write Button** on the ZONE Table Editing Dialog Box.

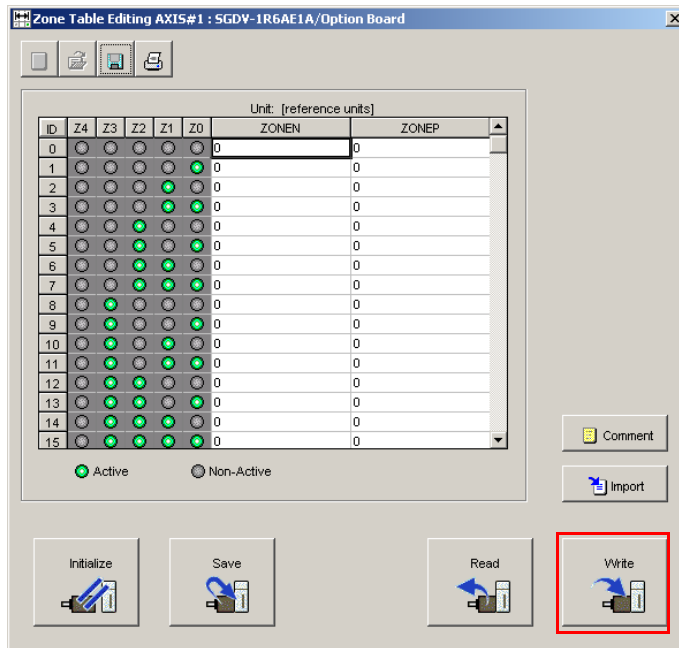

The Write Dialog Box will be displayed.

2. Click the **OK Button**.



The ZONE table edited on the SigmaWin+ will be written to the SERVOPACK and all edited rows will change to white.

7.5 ZONE Outputs

7.5.3 SigmaWin+ Procedures

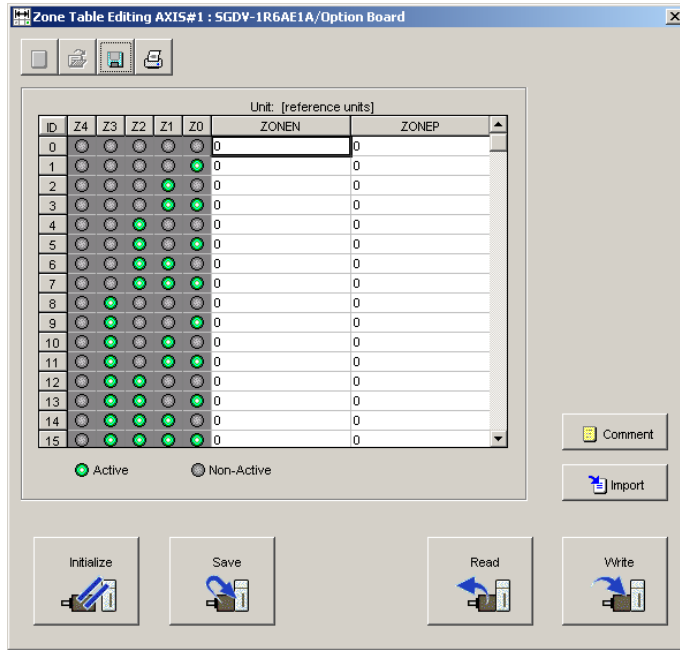

This concludes the writing procedure.

Saving the ZONE Table

◆ Saving the ZONE Table to Flash Memory in the SERVOPACK

To prevent the ZONE table from being deleted when the power supply to the SERVOPACK is turned OFF, you must save it to flash memory in the SERVOPACK. The ZONE table that is saved in the flash memory is automatically loaded each time the power supply is turned ON.

There are the following two ways to save the ZONE table to flash memory in the SERVOPACK.

- Save it on the ZONE Table Editing Dialog Box.
- Save it with Fn061 (Edit/Save ZONE Table) on a Digital Operator.

Use the following procedure to save the ZONE table from the ZONE Editing Dialog Box.

1. Click the **Save** Button on the ZONE Table Editing Dialog Box.

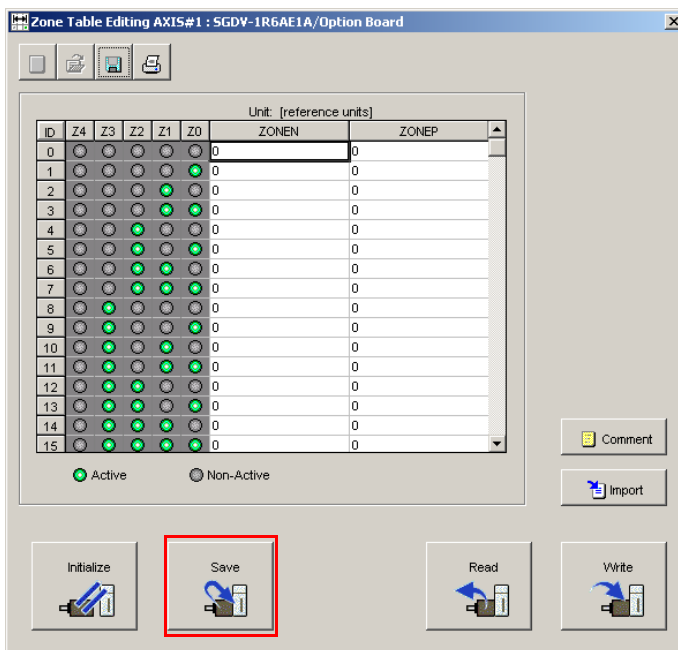

The Save Table Dialog Box will be displayed.

2. Click the **OK** Button.

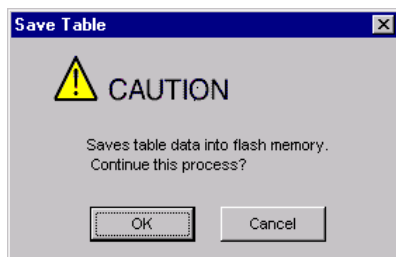

This concludes the saving procedure.

Maintenance



This chapter provides information on the meaning of, causes of, and corrections for alarms and warnings.

8.1	Alarm Displays	8-2
8.1.1	List of Alarms	8-2
8.1.2	Troubleshooting Alarms	8-8
8.1.3	INDEXER Alarm Displays and Troubleshooting	8-36
8.2	Warning Displays	8-38
8.2.1	List of Warnings	8-38
8.2.2	Troubleshooting Warnings	8-40
8.2.3	INDEXER Warning Displays and Troubleshooting	8-45
8.3	Troubleshooting Based on the Operation and Conditions of the Servomotor	8-49

8.1 Alarm Displays

If an error occurs in the SERVOPACK, the status is displayed as described below.

◆ Status Display

SERVOPACK Panel Display	The alarm number will be displayed. Refer to the following manual for details.  Σ -7-Series Σ -7S SERVOPACK with Analog Voltage/Pulse Train References Product Manual (Manual No.: SIEP S800001 26)
Digital Operator	The alarm code is displayed at the top left of the screen.
ALM Signal	The alarm signal turns ON. (The photocoupler turns OFF.)
/WARN Signal	No change

A list of the alarms that may occur and the causes of and corrections for those alarms are given below.

8.1.1 List of Alarms

This section gives the alarm names, alarm meanings, alarm stopping methods, alarm reset possibilities, and alarm code outputs in order of the alarm numbers.

Servomotor Stopping Method for Alarms

Refer to the following manual for information on the stopping method for alarms.

 Σ -7-Series Σ -7S SERVOPACK with Analog Voltage/Pulse Train References Product Manual (Manual No.: SIEP S800001 26)

Alarm Reset Possibility

Yes: You can use an alarm reset to clear the alarm. However, this assumes that the cause of the alarm has been removed.

No: You cannot clear the alarm.

List of Alarms

Alarm Number	Alarm Name	Alarm Meaning	Servo-motor Stopping Method	Alarm Reset Possible?	Alarm Code Output		
					/ALO1	/ALO2	/ALO3
A.020	Parameter Checksum Error	There is an error in the parameter data in the SERVOPACK.	Gr.1	No			
A.021	Parameter Format Error	There is an error in the parameter data format in the SERVOPACK.	Gr.1	No			
A.022	System Checksum Error	There is an error in the parameter data in the SERVOPACK.	Gr.1	No			
A.024	System Alarm	An internal program error occurred in the SERVOPACK.	Gr.1	No			
A.025	System Alarm	An internal program error occurred in the SERVOPACK.	Gr.1	No			
A.030	Main Circuit Detector Error	There is an error in the detection data for the main circuit.	Gr.1	Yes			
A.040	Parameter Setting Error	A parameter setting is outside of the setting range.	Gr.1	No			
A.041	Encoder Output Pulse Setting Error	The setting of Pn212 (Encoder Output Pulses) or Pn281 (Encoder Output Resolution) is outside of the setting range or does not satisfy the setting conditions.	Gr.1	No			
A.042	Parameter Combination Error	The combination of some parameters exceeds the setting range.	Gr.1	No	H	H	H
A.044	Semi-Closed/Fully-Closed Loop Control Parameter Setting Error	The settings of the Option Module and Pn002 = n.X□□□ (External Encoder Usage) do not match.	Gr.1	No			
A.04A	Parameter Setting Error 2	There is an error in setting of parameters reserved by the system.	Gr.1	No			
A.050	Combination Error	The capacities of the SERVOPACK and Servomotor do not match.	Gr.1	Yes			
A.051	Unsupported Device Alarm	An unsupported device was connected.	Gr.1	No			
A.070	Motor Type Change Detected	The connected motor is a different type of motor from the previously connected motor.	Gr.1	No			
A.080	Linear Encoder Pitch Setting Error	The setting of Pn282 (Linear Encoder Pitch) has not been changed from the default setting.	Gr.1	No			
A.0b0	Invalid Servo ON Command Alarm	The /S-ON (Servo ON) signal was input from the host controller after a utility function that turns ON the Servomotor was executed.	Gr.1	Yes			
A.100	Overcurrent Detected	An overcurrent flowed through the power transformer or the heat sink overheated.	Gr.1	No	L	H	H
A.101	Motor Overcurrent Detected	The current to the motor exceeded the allowable current.	Gr.1	No			
A.300	Regeneration Error	There is an error related to regeneration.	Gr.1	Yes			
A.320	Regenerative Overload	A regenerative overload occurred.	Gr.2	Yes			
A.330	Main Circuit Power Supply Wiring Error	<ul style="list-style-type: none"> The AC power supply input setting or DC power supply input setting is not correct. The power supply wiring is not correct. 	Gr.1	Yes	L	L	H

Continued on next page.

8.1 Alarm Displays

8.1.1 List of Alarms

Continued from previous page.

Alarm Number	Alarm Name	Alarm Meaning	Servo-motor Stopping Method	Alarm Reset Possible?	Alarm Code Output		
					/ALO1	/ALO2	/ALO3
A.400	Overvoltage	The main circuit DC voltage is too high.	Gr.1	Yes	H	H	L
A.410	Undervoltage	The main circuit DC voltage is too low.	Gr.2	Yes			
A.510	Overspeed	The motor exceeded the maximum speed.	Gr.1	Yes	L	H	L
A.511	Encoder Output Pulse Overspeed	<ul style="list-style-type: none"> Rotary Servomotor: The pulse output speed for the setting of Pn212 (Encoder Output Pulses) was exceeded. Linear Servomotor: The motor speed upper limit for the setting of Pn281 (Encoder Output Resolution) was exceeded. 	Gr.1	Yes			
A.520	Vibration Alarm	Abnormal oscillation was detected in the motor speed.	Gr.1	Yes			
A.521	Autotuning Alarm	Vibration was detected during autotuning for the tuning-less function.	Gr.1	Yes			
A.550	Maximum Speed Setting Error	The setting of Pn385 (Maximum Motor Speed) is greater than the maximum motor speed.	Gr.1	Yes			
A.710	Instantaneous Overload	The Servomotor was operating for several seconds to several tens of seconds under a torque that largely exceeded the rating.	Gr.2	Yes	L	L	L
A.720	Continuous Overload	The Servomotor was operating continuously under a torque that exceeded the rating.	Gr.1	Yes			
A.730	Dynamic Brake Overload	When the dynamic brake was applied, the rotational or linear kinetic energy exceeded the capacity of the dynamic brake resistor.	Gr.1	Yes			
A.731							
A.740	Inrush Current Limiting Resistor Overload	The main circuit power supply was frequently turned ON and OFF.	Gr.1	Yes			
A.7A1	Internal Temperature Error 1 (Control Board Temperature Error)	The surrounding temperature of the control PCB is abnormal.	Gr.2	Yes			
A.7A2	Internal Temperature Error 2 (Power Board Temperature Error)	The surrounding temperature of the power PCB is abnormal.	Gr.2	Yes			
A.7A3	Internal Temperature Sensor Error	An error occurred in the temperature sensor circuit.	Gr.2	No			
A.7Ab	SERVOPACK Built-in Fan Stopped	The fan inside the SERVOPACK stopped.	Gr.1	Yes			

Continued on next page.

Continued from previous page.

Alarm Number	Alarm Name	Alarm Meaning	Servo-motor Stopping Method	Alarm Reset Possible?	Alarm Code Output		
					/ALO1	/ALO2	/ALO3
A.810	Encoder Backup Alarm	The power supplies to the encoder all failed and the position data was lost.	Gr.1	No			
A.820	Encoder Checksum Alarm	There is an error in the checksum results for encoder memory.	Gr.1	No			
A.830	Encoder Battery Alarm	The battery voltage was lower than the specified level after the control power supply was turned ON.	Gr.1	Yes			
A.840	Encoder Data Alarm	There is an internal data error in the encoder.	Gr.1	No			
A.850	Encoder Overspeed	The encoder was operating at high speed when the power was turned ON.	Gr.1	No			
A.860	Encoder Overheated	The internal temperature of encoder is too high.	Gr.1	No			
A.861	Motor Overheated	The internal temperature of motor is too high.	Gr.1	No			
A.890	Encoder Scale Error	A failure occurred in the linear encoder.	Gr.1	No			
A.891	Encoder Module Error	An error occurred in the linear encoder.	Gr.1	No			
A.8A0	External Encoder Error	An error occurred in the external encoder.	Gr.1	Yes			
A.8A1	External Encoder Module Error	An error occurred in the Serial Converter Unit.	Gr.1	Yes			
A.8A2	External Incremental Encoder Sensor Error	An error occurred in the external encoder.	Gr.1	Yes			
A.8A3	External Absolute Encoder Position Error	An error occurred in the position data of the external encoder.	Gr.1	Yes	H	H	H
A.8A5	External Encoder Overspeed	An overspeed error occurred in the external encoder.	Gr.1	Yes			
A.8A6	External Encoder Overheated	An overheating error occurred in the external encoder.	Gr.1	Yes			
A.b33	Current Detection Error 3	An error occurred in the current detection circuit.	Gr.1	No			
A.bF0	System Alarm 0	Internal program error 0 occurred in the SERVOPACK.	Gr.1	No			
A.bF1	System Alarm 1	Internal program error 1 occurred in the SERVOPACK.	Gr.1	No			
A.bF2	System Alarm 2	Internal program error 2 occurred in the SERVOPACK.	Gr.1	No			
A.bF3	System Alarm 3	Internal program error 3 occurred in the SERVOPACK.	Gr.1	No			
A.bF4	System Alarm 4	Internal program error 4 occurred in the SERVOPACK.	Gr.1	No			
A.bF5	System Alarm 5	Internal program error 5 occurred in the SERVOPACK.	Gr.1	No			
A.bF6	System Alarm 6	Internal program error 6 occurred in the SERVOPACK.	Gr.1	No			
A.bF7	System Alarm 7	Internal program error 7 occurred in the SERVOPACK.	Gr.1	No			
A.bF8	System Alarm 8	Internal program error 8 occurred in the SERVOPACK.	Gr.1	No			

Continued on next page.

8.1 Alarm Displays

8.1.1 List of Alarms

Continued from previous page.

Alarm Number	Alarm Name	Alarm Meaning	Servo-motor Stopping Method	Alarm Reset Possible?	Alarm Code Output		
					/ALO1	/ALO2	/ALO3
A.C10	Servomotor Out of Control	The Servomotor ran out of control.	Gr.1	Yes	L	H	L
A.C20	Phase Detection Error	The detection of the phase is not correct.	Gr.1	No			
A.C21	Polarity Sensor Error	An error occurred in the polarity sensor.	Gr.1	No			
A.C22	Phase Information Disagreement	The phase information does not match.	Gr.1	No			
A.C50	Polarity Detection Failure	The polarity detection failed.	Gr.1	No			
A.C51	Overtravel Detected during Polarity Detection	The overtravel signal was detected during polarity detection.	Gr.1	Yes			
A.C52	Polarity Detection Not Completed	The servo was turned ON before the polarity was detected.	Gr.1	Yes			
A.C53	Out of Range of Motion for Polarity Detection	The travel distance exceeded the setting of Pn48E (Polarity Detection Range).	Gr.1	No			
A.C54	Polarity Detection Failure 2	The polarity detection failed.	Gr.1	No			
A.C80	Encoder Clear Error or Multiturn Limit Setting Error	The multiturn data for the absolute encoder was not correctly cleared or set.	Gr.1	No			
A.C90	Encoder Communications Error	Communications between the encoder and SERVOPACK is not possible.	Gr.1	No			
A.C91	Encoder Communications Position Data Acceleration Rate Error	An error occurred in calculating the position data of the encoder.	Gr.1	No			
A.C92	Encoder Communications Timer Error	An error occurred in the communications timer between the encoder and SERVOPACK.	Gr.1	No			
A.CA0	Encoder Parameter Error	The parameters in the encoder are corrupted.	Gr.1	No			
A.Cb0	Encoder Echoback Error	The contents of communications with the encoder are incorrect.	Gr.1	No			
A.CC0	Multiturn Limit Disagreement	Different multiturn limits have been set in the encoder and the SERVOPACK.	Gr.1	No			
A.CF1	Reception Failed Error in Feedback Option Module Communications	Receiving data from the Feedback Option Module failed.	Gr.1	No			
A.CF2	Timer Stopped Error in Feedback Option Module Communications	An error occurred in the timer for communications with the Feedback Option Module.	Gr.1	No			

Continued on next page.

Continued from previous page.

Alarm Number	Alarm Name	Alarm Meaning	Servo-motor Stopping Method	Alarm Reset Possible?	Alarm Code Output		
					/ALO1	/ALO2	/ALO3
A.d00	Position Deviation Overflow	The setting of Pn520 (Excessive Position Deviation Alarm Level) was exceeded by the position deviation while the servo was ON.	Gr.1	Yes			
A.d01	Position Deviation Overflow Alarm at Servo ON	The servo was turned ON after the position deviation exceeded the setting of Pn526 (Excessive Position Deviation Alarm Level at Servo ON) while the servo was OFF.	Gr.1	Yes			
A.d02	Position Deviation Overflow Alarm for Speed Limit at Servo ON	If position deviation remains in the deviation counter, the setting of Pn529 or Pn584 (Speed Limit Level at Servo ON) limits the speed when the servo is turned ON. This alarm occurs if a position reference is input and the setting of Pn520 (Excessive Position Deviation Alarm Level) is exceeded before the limit is cleared.	Gr.2	Yes	L	L	H
A.d10	Motor-Load Position Deviation Overflow	There was too much position deviation between the motor and load during fully-closed loop control.	Gr.2	Yes			
A.d30	Position Data Overflow	The position feedback data exceeded $\pm 1,879,048,192$.	Gr.1	No			
A.E71	Safety Option Module Detection Failure	Detection of the safety option module failed.	Gr.1	No			
A.E72	Feedback Option Module Detection Failure	Detection of the Feedback Option Module failed.	Gr.1	No			
A.E74	Unsupported Safety Option Module	An unsupported safety option module was connected.	Gr.1	No	H	L	L
A.E75	Unsupported Feedback Option Module	An unsupported feedback option module was connected.	Gr.1	No			
A.Eb1	Safety Function Signal Input Timing Error	An error occurred in the input timing of the safety function signal.	Gr.1	No			
A.EC8	Gate Drive Error 1	An error occurred in the gate drive circuit.	Gr.1	No			
A.EC9	Gate Drive Error 2	An error occurred in the gate drive circuit.	Gr.1	No			
A.EF9	INDEXER Alarm	An alarm occurred in the INDEXER.	Gr.1	Yes			
A.F10	Power Supply Line Open Phase	The voltage was low for more than one second for phase R, S, or T when the main power supply was ON.	Gr.2	Yes	H	L	H
A.F50	Servomotor Main Circuit Cable Disconnection	The Servomotor did not operate or power was not supplied to the Servomotor even though the /S-ON signal was input when the Servomotor was ready to receive it.	Gr.1	Yes			
FL-1*	System Alarm	An internal program error occurred in the SERVOPACK.	-	No			Invalid
FL-2*							
FL-3*							
FL-4*							
FL-5*							
FL-6*							
CPF00	Digital Operator Communications Error 1	Communications were not possible between the Digital Operator (model: JUSP-OP05A-1-E) and the SERVOPACK (e.g., a CPU error occurred).	-	No			
CPF01	Digital Operator Communications Error 2						

* These alarms are not stored in the alarm history. They are only displayed on the panel display.

8.1.2 Troubleshooting Alarms

The causes of and corrections for the alarms are given in the following table. Contact your Yaskawa representative if you cannot solve a problem with the correction given in the table.

Alarm Number: Alarm Name	Possible Cause	Confirmation	Correction	Reference
A.020: Parameter Checksum Error (There is an error in the parameter data in the SER- VOPACK.)	The power supply voltage suddenly dropped.	Measure the power supply voltage.	Set the power supply voltage within the specified range, and initialize the parameter settings.	*1
	The power supply was shut OFF while writing parameter settings.	Check the timing of shutting OFF the power supply.	Initialize the parameter settings and then set the parameters again.	
	The number of times that parameters were written exceeded the limit.	Check to see if the parameters were frequently changed from the host controller.	The SERVOPACK may be faulty. Replace the SERVOPACK. Reconsider the method for writing the parameters.	*1
	A malfunction was caused by noise from the AC power supply, ground, static electricity, or other source.	Turn the power supply to the SERVOPACK OFF and ON again. If the alarm still occurs, noise may be the cause.	Implement countermeasures against noise.	-
	Gas, water drops, or cutting oil entered the SERVOPACK and caused failure of the internal components.	Check the installation conditions.	The SERVOPACK may be faulty. Replace the SERVOPACK.	-
	A failure occurred in the SERVOPACK.	Turn the power supply to the SERVOPACK OFF and ON again. If the alarm still occurs, the SERVOPACK may have failed.	The SERVOPACK may be faulty. Replace the SERVOPACK.	-
A.021: Parameter Format Error (There is an error in the parameter data format in the SERVOPACK.)	The software version of the SERVOPACK that caused the alarm is older than the software version of the parameters specified to write.	Read the product information to see if the software versions are the same. If they are different, it could be the cause of the alarm.	Write the parameters from another SERVOPACK with the same model and the same software version, and then turn the power OFF and ON again.	*1
	A failure occurred in the SERVOPACK.	-	The SERVOPACK may be faulty. Replace the SERVOPACK.	-
A.022: System Checksum Error (There is an error in the parameter data in the SERVOPACK.)	The power supply voltage suddenly dropped.	Measure the power supply voltage.	The SERVOPACK may be faulty. Replace the SERVOPACK.	-
	The power supply was shut OFF while setting a utility function.	Check the timing of shutting OFF the power supply.	The SERVOPACK may be faulty. Replace the SERVOPACK.	-
	A failure occurred in the SERVOPACK.	Turn the power supply to the SERVOPACK OFF and ON again. If the alarm still occurs, the SERVOPACK may have failed.	The SERVOPACK may be faulty. Replace the SERVOPACK.	-

Continued from previous page.

Alarm Number: Alarm Name	Possible Cause	Confirmation	Correction	Reference
A.024: System Alarm (An internal program error occurred in the SERVOPACK.)	A failure occurred in the SERVOPACK.	–	The SERVOPACK may be faulty. Replace the SERVOPACK.	–
A.025: System Alarm (An internal program error occurred in the SERVOPACK.)	A failure occurred in the SERVOPACK.	–	The SERVOPACK may be faulty. Replace the SERVOPACK.	–
A.030: Main Circuit Detector Error	A failure occurred in the SERVOPACK.	–	The SERVOPACK may be faulty. Replace the SERVOPACK.	–
A.040: Parameter Setting Error (A parameter setting is outside of the setting range.)	The SERVOPACK and Servomotor capacities do not match each other.	Check the combination of the SERVOPACK and Servomotor capacities.	Select a proper combination of SERVOPACK and Servomotor capacities.	page 1-4
	A failure occurred in the SERVOPACK.	–	The SERVOPACK may be faulty. Replace the SERVOPACK.	–
	A parameter setting is outside of the setting range.	Check the setting ranges of the parameters that have been changed.	Set the parameters to values within the setting ranges.	–
	The electronic gear ratio is outside of the setting range.	Check the electronic gear ratio. The ratio must be within the following range: $0.001 < (Pn20E/Pn210) < 64,000$.	Set the electronic gear ratio in the following range: $0.001 < (Pn20E/Pn210) < 64,000$.	*1
	The origin setting is out of range.	Check to see if the origin is between the settings of Pn638 and Pn63A.	Set the origin between Pn638 and Pn63A.	–
A.041: Encoder Output Pulse Setting Error	The setting of Pn212 (Encoder Output Pulses) or Pn281 (Encoder Output Resolution) is outside of the setting range or does not satisfy the setting conditions.	Check the setting of Pn212 or Pn281.	Set Pn212 or Pn281 to an appropriate value.	*1

8.1 Alarm Displays

8.1.2 Troubleshooting Alarms

Continued from previous page.

Alarm Number: Alarm Name	Possible Cause	Confirmation	Correction	Reference
A.042: Parameter Combination Error	The speed of program jog operation went below the setting range when the electronic gear ratio (Pn20E/Pn210) or the Servomotor was changed.	Check to see if the detection conditions*2 are satisfied.	Decrease the setting of the electronic gear ratio (Pn20E/Pn210).	*1
	The speed of program jog operation went below the setting range when Pn533 or Pn585 (Program Jog Operation Speed) was changed.	Check to see if the detection conditions*2 are satisfied.	Increase the setting of Pn533 or Pn585.	*1
	The movement speed of advanced autotuning went below the setting range when the electronic gear ratio (Pn20E/ Pn210) or the Servomotor was changed.	Check to see if the detection conditions*3 are satisfied.	Decrease the setting of the electronic gear ratio (Pn20E/Pn210).	*1
A.044: Semi-Closed/ Fully-Closed Loop Control Parameter Setting Error	The setting of the Fully-Closed Module does not match the setting of Pn002 = n.X□□□ (External Encoder Usage).	Check the setting of Pn002 = n.X□□□.	Make sure that the setting of the Fully-closed Module agrees with the setting of Pn002 = n.X□□□.	*1
A.04A: Parameter Setting Error 2	A parameter reserved by the system was changed.	–	Set the following reserved parameters to the default settings. Pn200.2 Pn207.1 Pn50A.0 Pn50A.1 Pn50A.2 Pn50C Pn50D	–
A.050: Combination Error (The capacities of the SERVOPACK and Servomotor do not match.)	The SERVOPACK and Servomotor capacities do not match each other.	Check the capacities to see if they satisfy the following condition: $\frac{1}{4} \leq \frac{\text{Servomotor capacity}}{\text{SERVOPACK capacity}} \leq 4$	Select a proper combination of the SERVOPACK and Servomotor capacities.	page 1-4
	A failure occurred in the encoder.	Replace the encoder and check to see if the alarm still occurs.	Replace the Servomotor or encoder.	–
	A failure occurred in the SERVOPACK.	–	The SERVOPACK may be faulty. Replace the SERVOPACK.	–
A.051: Unsupported Device Alarm	The motor parameter file was not written to the linear encoder. (This applies only when not using a Serial Converter Unit.)	Check to see if the motor parameter file was written to the linear encoder.	Write the motor parameter file to the linear encoder.	*1
	An unsupported Serial Converter Unit or encoder (e.g., an external encoder) is connected to the SERVOPACK.	Check the product combination specifications.	Change to a correct combination of models.	–

Continued from previous page.

Alarm Number: Alarm Name	Possible Cause	Confirmation	Correction	Reference
A.070: Motor Type Change Detected (The connected motor is a differ- ent type of motor from the previ- ously connected motor.)	A Rotary Servomotor was removed and a Linear Servomotor was connected.	–	Set the parameters for a Linear Servomotor and reset the motor type alarm. Then, turn the power supply to the SER- VOPACK OFF and ON again.	*1
	A Linear Servomotor was removed and a Rotary Servomotor was connected.	–	Set the parameters for a Rotary Servomotor and reset the motor type alarm. Then, turn the power supply to the SER- VOPACK OFF and ON again.	*1
A.080: Linear Encoder Pitch Setting Error	The setting of Pn282 (Linear Encoder Pitch) has not been changed from the default set- ting.	Check the setting of Pn282.	Correct the setting of Pn282.	*1
A.0b0: Invalid Servo ON Command Alarm	The /S-ON (Servo ON) signal was input from the host controller after a utility function that turns ON the Ser- vomotor was exe- cuted.	–	Turn the power supply to the SERVOPACK OFF and ON again. Or, execute a software reset.	–

8.1 Alarm Displays

8.1.2 Troubleshooting Alarms

Continued from previous page.

Alarm Number: Alarm Name	Possible Cause	Confirmation	Correction	Reference
A.100: Overcurrent Detected (An overcurrent flowed through the power trans- former or the heat sink overheated.)	The Main Circuit Cable is not wired correctly or there is faulty contact.	Check the wiring.	Correct the wiring.	
	There is a short-circuit or ground fault in a Main Circuit Cable.	Check for short-circuits across cable phases U, V, and W, or between the ground and cable phases U, V, and W.	The cable may be short-circuited. Replace the cable.	
	There is a short-circuit or ground fault inside the Servomotor.	Check for short-circuits across Servomotor phases U, V, and W, or between the ground and Servomotor phases U, V, or W.	The Servomotor may be faulty. Replace the Servomotor.	*1
	There is a short-circuit or ground fault inside the SERVOPACK.	Check for short-circuits across the Servomotor connection terminals U, V, and W on the SERVOPACK, or between the ground and terminals U, V, or W.	The SERVOPACK may be faulty. Replace the SERVOPACK.	
	The regenerative resistor is not wired correctly or there is faulty contact.	Check the wiring.	Correct the wiring.	*1
	The dynamic brake (DB, emergency stop executed from the SERVOPACK) was frequently activated, or a DB overload alarm occurred.	Check the power consumed by the DB resistor to see how frequently the DB is being used. Or, check the alarm display to see if a DB overload alarm (A.730 or A.731) has occurred.	Change the SERVOPACK model, operating methods, or the mechanisms so that the dynamic brake does not need to be used so frequently.	-
	The regenerative resistor value exceeded the SERVOPACK regenerative processing capacity.	Check the regenerative load ratio in the SigmaWin+ Motion Monitor Tab Page to see how frequently the regenerative resistor is being used.	Select a regenerative resistance value that is appropriate for the operating conditions and load.	*4
	The SERVOPACK regenerative resistance is too small.	Check the regenerative load ratio in the SigmaWin+ Motion Monitor Tab Page to see how frequently the regenerative resistor is being used.	Change the regenerative resistance to a value larger than the SERVOPACK minimum allowable resistance.	

Continued from previous page.

Alarm Number: Alarm Name	Possible Cause	Confirmation	Correction	Reference
A.100: Overcurrent Detected (An overcurrent flowed through the power trans- former or the heat sink overheated.)	A heavy load was applied while the Servomotor was stopped or running at a low speed.	Check to see if the operating conditions exceed Servo Drive specifications.	Reduce the load applied to the Servomotor. Or, increase the operating speed.	–
	A malfunction was caused by noise.	Improve the noise environment, e.g. by improving the wiring or installation conditions, and check to see if the alarm still occurs.	Implement countermeasures against noise, such as correct wiring of the FG. Use an FG wire size equivalent to the SERVOPACK's main circuit wire size.	–
	A failure occurred in the SERVOPACK.	–	Turn the power supply to the SERVOPACK OFF and ON again. If an alarm still occurs, the SERVOPACK may be faulty. Replace the SERVOPACK.	–
A.101: Motor Overcurrent Detected (The current to the motor exceeded the allowable current.)	The Main Circuit Cable is not wired correctly or there is faulty contact.	Check the wiring.	Correct the wiring.	
	There is a short-circuit or ground fault in a Main Circuit Cable.	Check for short-circuits across cable phases U, V, and W, or between the ground and cable phases U, V, and W.	The cable may be short-circuited. Replace the cable.	
	There is a short-circuit or ground fault inside the Servomotor.	Check for short-circuits across Servomotor phases U, V, and W, or between the ground and Servomotor phases U, V, or W.	The Servomotor may be faulty. Replace the Servomotor.	*1
	There is a short-circuit or ground fault inside the SERVOPACK.	Check for short-circuits across the Servomotor connection terminals U, V, and W on the SERVOPACK, or between the ground and terminals U, V, or W.	The SERVOPACK may be faulty. Replace the SERVOPACK.	
	A heavy load was applied while the Servomotor was stopped or running at a low speed.	Check to see if the operating conditions exceed Servo Drive specifications.	Reduce the load applied to the Servomotor. Or, increase the operating speed.	–
	A malfunction was caused by noise.	Improve the noise environment, e.g. by improving the wiring or installation conditions, and check to see if the alarm still occurs.	Implement countermeasures against noise, such as correct wiring of the FG. Use an FG wire size equivalent to the SERVOPACK's main circuit wire size.	–
	A failure occurred in the SERVOPACK.	–	Turn the power supply to the SERVOPACK OFF and ON again. If an alarm still occurs, the SERVOPACK may be faulty. Replace the SERVOPACK.	–

8.1 Alarm Displays

8.1.2 Troubleshooting Alarms

Continued from previous page.

Alarm Number: Alarm Name	Possible Cause	Confirmation	Correction	Reference
A.300: Regeneration Error	Pn600 (Regenerative Resistor Capacity) is not set to 0 and an External Regenerative Resistor is not connected to one of the following SERVO-PACKs: SGD7S-R70A, -R90A, -1R6A, or -2R8A.	Check to see if an External Regenerative Resistor is connected and check the setting of Pn600.	Connect an External Regenerative Resistor, or set Pn600 (Regenerative Resistor Capacity) to 0 (setting unit: $\times 10\text{ W}$) if no Regenerative Resistor is required.	*1
	An External Regenerative Resistor is not connected to one of the following SERVO-PACKs: SGD7S-470A, -550A, -590A, or -780A.	Check to see if an External Regenerative Resistor or a Regenerative Resistor Unit is connected and check the setting of Pn600.	Connect an External Regenerative Resistor and set Pn600 to an appropriate value, or connect a Regenerative Resistor Unit and set Pn600 to 0.	
	The jumper between the regenerative resistor terminals (B2 and B3) was removed from one of the following SERVO-PACKs: SGD7S-3R8A, -5R5A, -7R6A, -120A, -180A, -200A or -330A.	Check to see if the jumper is connected between power supply terminals.	Correctly connect a jumper.	*1
	The External Regenerative Resistor is not wired correctly, or was removed or disconnected.	Check the wiring of the External Regenerative Resistor.	Correct the wiring of the External Regenerative Resistor.	
	A failure occurred in the SERVOPACK.	-	While the main circuit power supply is OFF, turn the control power supply to the SERVOPACK OFF and ON again. If an alarm still occurs, the SERVOPACK may be faulty. Replace the SERVOPACK.	-

Continued from previous page.

Alarm Number: Alarm Name	Possible Cause	Confirmation	Correction	Reference
A.320: Regenerative Overload	The power supply voltage exceeded the specified range.	Measure the power supply voltage.	Set the power supply voltage within the specified range.	–
	The external regenerative resistance value or regenerative resistor capacity is too small, or there has been a continuous regeneration state.	Check the operating conditions or the capacity using the SigmaJunmaSize+ Capacity Selection Software or other means.	Change the regenerative resistance value or capacity. Reconsider the operating conditions using the SigmaJunmaSize+ Capacity Selection Software or other means.	*4
	There was a continuous regeneration state because a negative load was continuously applied.	Check the load applied to the Servomotor during operation.	Reconsider the system including the servo, machine, and operating conditions.	–
	The setting of Pn600 (Regenerative Resistor Capacity) is smaller than the capacity of the External Regenerative Resistor.	Check to see if a Regenerative Resistor is connected and check the setting of Pn600.	Correct the setting of Pn600.	*1
	The setting of Pn603 (Regenerative Resistor Capacity) is smaller than the capacity of the External Regenerative Resistor.	Check to see if a Regenerative Resistor is connected and check the setting of Pn603.	Correct the setting of Pn603.	*1
	The external regenerative resistance is too high.	Check the regenerative resistance.	Change the regenerative resistance to a correct value or use an External Regenerative Resistor of an appropriate capacity.	*1
	A failure occurred in the SERVOPACK.	–	The SERVOPACK may be faulty. Replace the SERVOPACK.	–

8.1 Alarm Displays

8.1.2 Troubleshooting Alarms

Continued from previous page.

Alarm Number: Alarm Name	Possible Cause	Confirmation	Correction	Reference
A.330: Main Circuit Power Supply Wiring Error (Detected when the main circuit power supply is turned ON.)	The regenerative resistor was disconnected when the SERVOPACK power supply voltage was high.	Measure the resistance of the regenerative resistor using a measuring instrument.	If you are using the regenerative resistor built into the SERVOPACK, replace the SERVOPACK. If you are using an External Regenerative Resistor, replace the External Regenerative Resistor.	–
	DC power was supplied when an AC power supply input was specified in the settings.	Check the power supply to see if it is a DC power supply.	Correct the power supply setting to match the actual power supply.	*1
	AC power was supplied when a DC power supply input was specified in the settings.	Check the power supply to see if it is an AC power supply.	Correct the power supply setting to match the actual power supply.	–
	Pn600 (Regenerative Resistor Capacity) is not set to 0 and an External Regenerative Resistor is not connected to one of the following SERVOPACKs: SGD7S-R70A, -R90A, -1R6A, or -2R8A.	Check to see if an External Regenerative Resistor is connected and check the setting of Pn600.	Connect an External Regenerative Resistor, or if an External Regenerative Resistor is not required, set Pn600 to 0.	*1
	A failure occurred in the SERVOPACK.	–	The SERVOPACK may be faulty. Replace the SERVOPACK.	–
A.400: Overvoltage (Detected in the main circuit power supply section of the SERVOPACK.)	The power supply voltage exceeded the specified range.	Measure the power supply voltage.	Set the AC/DC power supply voltage within the specified range.	–
	The power supply is not stable or was influenced by a lightning surge.	Measure the power supply voltage.	Improve the power supply conditions, install a surge absorber, and then turn the power supply OFF and ON again. If an alarm still occurs, the SERVOPACK may be faulty. Replace the SERVOPACK.	–
	The voltage for AC power supply was too high during acceleration or deceleration.	Check the power supply voltage and the speed and torque during operation.	Set the AC power supply voltage within the specified range.	–
	The external regenerative resistance is too high for the operating conditions.	Check the operating conditions and the regenerative resistance.	Select a regenerative resistance value that is appropriate for the operating conditions and load.	*4
	The moment of inertia ratio or mass ratio exceeded the allowable value.	Check to see if the moment of inertia ratio or mass ratio is within the allowable range.	Increase the deceleration time, or reduce the load.	–
	A failure occurred in the SERVOPACK.	–	While the main circuit power supply is OFF, turn the control power supply to the SERVOPACK OFF and ON again. If an alarm still occurs, the SERVOPACK may be faulty. Replace the SERVOPACK.	–

Continued from previous page.

Alarm Number: Alarm Name	Possible Cause	Confirmation	Correction	Reference
A.410: Undervoltage (Detected in the main circuit power supply section of the SERVOPACK.)	The power supply voltage went below the specified range.	Measure the power supply voltage.	Set the power supply voltage within the specified range.	–
	The power supply voltage dropped during operation.	Measure the power supply voltage.	Increase the power supply capacity.	–
	A momentary power interruption occurred.	Measure the power supply voltage.	If you have changed the setting of Pn509 (Momentary Power Interruption Hold Time), decrease the setting.	*1
	The SERVOPACK fuse is blown out.	–	Replace the SERVOPACK and connect a reactor to the DC reactor terminals (⊖1 and ⊖2) on the SERVOPACK.	–
	A failure occurred in the SERVOPACK.	–	The SERVOPACK may be faulty. Replace the SERVOPACK.	–
A.510: Overspeed (The motor exceeded the maximum speed.)	The order of phases U, V, and W in the motor wiring is not correct.	Check the wiring of the Servomotor.	Make sure that the Servomotor is correctly wired.	–
	A reference value that exceeded the overspeed detection level was input.	Check the input reference.	Reduce the reference value. Or, adjust the gain.	*1
	The motor exceeded the maximum speed.	Check the waveform of the motor speed.	Reduce the speed reference input gain and adjust the servo gain. Or, reconsider the operating conditions.	
	A failure occurred in the SERVOPACK.	–	The SERVOPACK may be faulty. Replace the SERVOPACK.	–
A.511: Encoder Output Pulse Overspeed	The encoder output pulse frequency exceeded the limit.	Check the encoder output pulse setting.	Decrease the setting of Pn212 (Encoder Output Pulses) or Pn281 (Encoder Output Resolution).	*1
	The encoder output pulse frequency exceeded the limit because the motor speed was too high.	Check the encoder output pulse setting and the motor speed.	Reduce the motor speed.	–
A.520: Vibration Alarm	Abnormal oscillation was detected in the motor speed.	Check for abnormal motor noise, and check the speed and torque waveforms during operation.	Reduce the motor speed. Or, reduce the setting of Pn100 (Speed Loop Gain).	*1
	The setting of Pn103 (Moment of Inertia Ratio) is greater than the actual moment of inertia or was greatly changed.	Check the moment of inertia ratio or mass ratio.	Set Pn103 (Moment of Inertia Ratio) to an appropriate value.	*1
	The vibration detection level (Pn312 or Pn384) is not suitable.	Check that the vibration detection level (Pn312 or Pn384) is suitable.	Set a suitable vibration detection level (Pn312 or Pn384).	*1

8.1 Alarm Displays

8.1.2 Troubleshooting Alarms

Continued from previous page.

Alarm Number: Alarm Name	Possible Cause	Confirmation	Correction	Reference
A.521: Autotuning Alarm (Vibration was detected while executing the custom tuning, EasyFFT, or the tuning-less function.)	The Servomotor vibrated considerably while performing the tuning-less function.	Check the waveform of the motor speed.	Reduce the load so that the moment of inertia ratio is within the allowable value. Or increase the load level or reduce the rigidity level in the tuning-less level settings.	*1
	The Servomotor vibrated considerably while performing custom tuning or EasyFFT.	Check the waveform of the motor speed.	Check the operating procedure of corresponding function and implement corrections.	*1
A.550: Maximum Speed Setting Error	The setting of Pn385 (Maximum Motor Speed) is greater than the maximum speed.	Check the setting of Pn385, and the upper limits of the maximum motor speed setting and the encoder output resolution setting.	Set Pn385 to a value that does not exceed the maximum motor speed.	*1
A.710: Instantaneous Overload A.720: Continuous Overload	The wiring is not correct or there is a faulty contact in the motor or encoder wiring.	Check the wiring.	Make sure that the Servomotor and encoder are correctly wired.	*1
	Operation was performed that exceeded the overload protection characteristics.	Check the motor overload characteristics and operation reference.	Reconsider the load and operating conditions. Or, increase the motor capacity.	–
	An excessive load was applied during operation because the Servomotor was not driven due to mechanical problems.	Check the operation reference and motor speed.	Correct the mechanical problem.	–
	There is an error in the setting of Pn282 (Linear Encoder Pitch).	Check the setting of Pn282.	Correct the setting of Pn282.	*1
	There is an error in the setting of Pn080 = n.□□X□ (Motor Phase Selection).	Check the setting of Pn080 = n.□□X□.	Set Pn080 = n.□□X□ to an appropriate value.	*1
	A failure occurred in the SERVOPACK.	–	The SERVOPACK may be faulty. Replace the SERVOPACK.	–
	A.730 and A.731: Dynamic Brake Overload (An excessive power consumption by the dynamic brake was detected.)	The Servomotor was rotated by an external force.	Check the operation status.	Implement measures to ensure that the motor will not be rotated by an external force.
	When the Servomotor was stopped with the dynamic brake, the rotational or linear kinetic energy exceeded the capacity of the dynamic brake resistor.	Check the power consumed by the DB resistor to see how frequently the DB is being used.	Reconsider the following: <ul style="list-style-type: none"> • Reduce the Servomotor command speed. • Decrease the moment of inertia ratio or mass ratio. • Reduce the frequency of stopping with the dynamic brake. 	–
	A failure occurred in the SERVOPACK.	–	The SERVOPACK may be faulty. Replace the SERVOPACK.	–

Continued from previous page.

Alarm Number: Alarm Name	Possible Cause	Confirmation	Correction	Reference
A.740: Inrush Current Limiting Resistor Overload (The main circuit power supply was frequently turned ON and OFF.)	The allowable frequency of the inrush current limiting resistor was exceeded when the main circuit power supply was turned ON and OFF.	–	Reduce the frequency of turning the main circuit power supply ON and OFF.	–
	A failure occurred in the SERVOPACK.	–	The SERVOPACK may be faulty. Replace the SERVOPACK.	–
A.7A1: Internal Temperature Error 1 (Control Board Temperature Error)	The surrounding temperature is too high.	Check the surrounding temperature using a thermostat. Or, check the operating status with the SERVOPACK installation environment monitor.	Decrease the surrounding temperature by improving the SERVOPACK installation conditions.	*1
	An overload alarm was reset by turning OFF the power supply too many times.	Check the alarm display to see if there is an overload alarm.	Change the method for resetting the alarm.	–
	There was an excessive load or operation was performed that exceeded the regenerative processing capacity.	Use the accumulated load ratio to check the load during operation, and use the regenerative load ratio to check the regenerative processing capacity.	Reconsider the load and operating conditions.	–
	The SERVOPACK installation orientation is not correct or there is insufficient space around the SERVOPACK.	Check the SERVOPACK installation conditions.	Install the SERVOPACK according to specifications.	*1
	A failure occurred in the SERVOPACK.	–	The SERVOPACK may be faulty. Replace the SERVOPACK.	–

8.1 Alarm Displays

8.1.2 Troubleshooting Alarms

Continued from previous page.

Alarm Number: Alarm Name	Possible Cause	Confirmation	Correction	Reference
A.7A2: Internal Temperature Error 2 (Power Board Temperature Error)	The surrounding temperature is too high.	Check the surrounding temperature using a thermostat. Or, check the operating status with the SERVOPACK installation environment monitor.	Decrease the surrounding temperature by improving the SERVOPACK installation conditions.	*1
	An overload alarm was reset by turning OFF the power supply too many times.	Check the alarm display to see if there is an overload alarm.	Change the method for resetting the alarm.	–
	There was an excessive load or operation was performed that exceeded the regenerative processing capacity.	Use the accumulated load ratio to check the load during operation, and use the regenerative load ratio to check the regenerative processing capacity.	Reconsider the load and operating conditions.	–
	The SERVOPACK installation orientation is not correct or there is insufficient space around the SERVOPACK.	Check the SERVOPACK installation conditions.	Install the SERVOPACK according to specifications.	*1
	A failure occurred in the SERVOPACK.	–	The SERVOPACK may be faulty. Replace the SERVOPACK.	–
A.7A3: Internal Temperature Sensor Error (An error occurred in the temperature sensor circuit.)	A failure occurred in the SERVOPACK.	–	The SERVOPACK may be faulty. Replace the SERVOPACK.	–
A.7Ab: SERVOPACK Built-in Fan Stopped	The fan inside the SERVOPACK stopped.	Check for foreign matter inside the SERVOPACK.	Remove foreign matter from the SERVOPACK. If an alarm still occurs, the SERVOPACK may be faulty. Replace the SERVOPACK.	–
A.810: Encoder Backup Alarm (Detected at the encoder, but only when an absolute encoder is used.)	The power to the absolute encoder was turned ON for the first time.	Check to see if the power supply was turned ON for the first time.	Set up the encoder.	
	The Encoder Cable was disconnected and then connected again.	Check to see if the power supply was turned ON for the first time.	Check the encoder connection and set up the encoder.	*1
	Power is not being supplied both from the control power supply (+5 V) from the SERVOPACK and from the battery power supply.	Check the encoder connector battery and the connector status.	Replace the battery or implement similar measures to supply power to the encoder, and set up the encoder.	
	A failure occurred in the absolute encoder.	–	If the alarm still occurs after setting up the encoder again, replace the Servomotor.	–
	A failure occurred in the SERVOPACK.	–	The SERVOPACK may be faulty. Replace the SERVOPACK.	–

Continued from previous page.

Alarm Number: Alarm Name	Possible Cause	Confirmation	Correction	Reference
A.820: Encoder Checksum Alarm (Detected at the encoder.)	A failure occurred in the encoder.	–	<ul style="list-style-type: none"> ■ When Using an Absolute Encoder Set up the encoder again. If the alarm still occurs, the Servomotor may be faulty. Replace the Servomotor. ■ When Using a Single-turn Absolute Encoder or Incremental Encoder <ul style="list-style-type: none"> • The Servomotor may be faulty. Replace the Servomotor. • The linear encoder may be faulty. Replace the linear encoder. 	*1
	A failure occurred in the SERVOPACK.	–	The SERVOPACK may be faulty. Replace the SERVOPACK.	–
A.830: Encoder Battery Alarm (The absolute encoder battery voltage was lower than the specified level.)	The battery connection is faulty or a battery is not connected.	Check the battery connection.	Correct the battery connection.	*1
	The battery voltage is lower than the specified value (2.7 V).	Measure the battery voltage.	Replace the battery.	*1
	A failure occurred in the SERVOPACK.	–	The SERVOPACK may be faulty. Replace the SERVOPACK.	–
A.840: Encoder Data Alarm (Detected at the encoder.)	The encoder malfunctioned.	–	Turn the power supply to the SERVOPACK OFF and ON again. If an alarm still occurs, the Servomotor or linear encoder may be faulty. Replace the Servomotor or linear encoder.	–
	An error occurred in reading data from the linear encoder.	–	The linear encoder is not mounted within an appropriate tolerance. Correct the mounting of the linear encoder.	–
	Excessive speed occurred in the linear encoder.	–	Control the motor speed within the range specified by the linear encoder manufacturer and then turn ON the control power supply.	–
	The encoder malfunctioned due to noise.	–	Correct the wiring around the encoder by separating the Encoder Cable from the Servomotor Main Circuit Cable or by grounding the encoder.	–
	The polarity sensor is not wired correctly.	Check the wiring of the polarity sensor.	Correct the wiring of the polarity sensor.	–
	The polarity sensor failed.	–	Replace the polarity sensor.	–

8.1 Alarm Displays

8.1.2 Troubleshooting Alarms

Continued from previous page.

Alarm Number: Alarm Name	Possible Cause	Confirmation	Correction	Reference
A.850: Encoder Overspeed (Detected at the encoder when the control power supply is turned ON.)	Rotary Servomotor: The Servomotor speed was 200 min ⁻¹ or higher when the control power supply was turned ON.	Check the motor speed when the power supply is turned ON.	Reduce the Servomotor speed to a value less than 200 min ⁻¹ , and turn ON the control power supply.	–
	Linear Servomotor: The Servomotor exceeded the speci- fied speed when the control power supply was turned ON.	Check the motor speed when the power supply is turned ON.	Control the motor speed within the range specified by the linear encoder manufacturer and then turn ON the control power supply.	–
	A failure occurred in the encoder.	–	Turn the power supply to the SERVOPACK OFF and ON again. If an alarm still occurs, the Servomotor or linear encoder may be faulty. Replace the Servo- motor or linear encoder.	–
	A failure occurred in the SERVOPACK.	–	Turn the power supply to the SERVOPACK OFF and ON again. If an alarm still occurs, the SERVOPACK may be faulty. Replace the SERVOPACK.	–
A.860: Encoder Overheated (Detected at the encoder, but only when an abso- lute encoder is used.)	The surrounding air temperature around the Servomotor is too high.	Measure the surround- ing air temperature around the Servomotor.	Reduce the surrounding air temperature of the Servomotor to 40°C or less.	–
	The Servomotor load is greater than the rated load.	Use the accumulated load ratio to check the load.	Operate the Servo Drive so that the motor load remains within the speci- fied range.	*1
	A failure occurred in the encoder.	–	Turn the power supply to the SERVOPACK OFF and ON again. If an alarm still occurs, the Servomotor or absolute linear encoder may be faulty. Replace the Servomotor or absolute linear encoder.	–
	A failure occurred in the SERVOPACK.	–	Turn the power supply to the SERVOPACK OFF and ON again. If an alarm still occurs, the SERVOPACK may be faulty. Replace the SERVOPACK.	–

Continued from previous page.

Alarm Number: Alarm Name	Possible Cause	Confirmation	Correction	Reference
A.861: Motor Overheated	The surrounding temperature around the Servomotor is too high.	Measure the surrounding temperature around the Servomotor.	Reduce the surrounding air temperature of the Servomotor to 40° or less.	–
	The motor load is greater than the rated load.	Check the load with the accumulated load ratio on the Motion Monitor Tab Page on the SigmaWin+.	Operate the Servo Drive so that the motor load remains within the specified range.	*1
	A failure occurred in the Serial Converter Unit.	–	Turn the power supply to the SERVOPACK OFF and ON again. If an alarm still occurs, the Serial Converter Unit may be faulty. Replace the Serial Converter Unit.	–
	A failure occurred in the SERVOPACK.	–	Turn the power supply to the SERVOPACK OFF and ON again. If an alarm still occurs, the SERVOPACK may be faulty. Replace the SERVOPACK.	–
A.890: Encoder Scale Error	A failure occurred in the linear encoder.	–	The linear encoder may be faulty. Replace the linear encoder.	–
A.891: Encoder Module Error	A failure occurred in the linear encoder.	–	Turn the power supply to the SERVOPACK OFF and ON again. If an alarm still occurs, the linear encoder may be faulty. Replace the linear encoder.	–
A.8A0: External Encoder Error	Setting the origin of the absolute linear encoder failed because the motor moved.	Before you set the origin, use the fully-closed feedback pulse counter to confirm that the motor is not moving.	The motor must be stopped while setting the origin position.	*1
	A failure occurred in the external encoder.	–	Replace the external encoder.	–
A.8A1: External Encoder Module Error	A failure occurred in the external encoder.	–	Replace the external encoder.	–
	A failure occurred in the Serial Converter Unit.	–	Replace the Serial Converter Unit.	–
A.8A2: External Incremental Encoder Sensor Error	A failure occurred in the external encoder.	–	Replace the external encoder.	–
A.8A3: External Absolute Encoder Position Error	A failure occurred in the external absolute encoder.	–	The external absolute encoder may be faulty. Refer to the encoder manufacturer's instruction manual for corrections.	–
A.8A5: External Encoder Overspeed	An overspeed error was detected in the external encoder.	Check the maximum speed of the external encoder.	Keep the external encoder below its maximum speed.	–
A.8A6: External Encoder Overheated	An overheating error was detected in the external encoder.	–	Replace the external encoder.	–

8.1 Alarm Displays

8.1.2 Troubleshooting Alarms

Continued from previous page.

Alarm Number: Alarm Name	Possible Cause	Confirmation	Correction	Reference
A.b33: Current Detection Error 3	A failure occurred in the current detection circuit.	–	Turn the power supply to the SERVOPACK OFF and ON again. If an alarm still occurs, the SERVOPACK may be faulty. Replace the SERVOPACK.	–
A.bF0: System Alarm 0	A failure occurred in the SERVOPACK.	–	Turn the power supply to the SERVOPACK OFF and ON again. If an alarm still occurs, the SERVOPACK may be faulty. Replace the SERVOPACK.	–
A.bF1: System Alarm 1	A failure occurred in the SERVOPACK.	–	Turn the power supply to the SERVOPACK OFF and ON again. If an alarm still occurs, the SERVOPACK may be faulty. Replace the SERVOPACK.	–
A.bF2: System Alarm 2	A failure occurred in the SERVOPACK.	–	Turn the power supply to the SERVOPACK OFF and ON again. If an alarm still occurs, the SERVOPACK may be faulty. Replace the SERVOPACK.	–
A.bF3: System Alarm 3	A failure occurred in the SERVOPACK.	–	Turn the power supply to the SERVOPACK OFF and ON again. If an alarm still occurs, the SERVOPACK may be faulty. Replace the SERVOPACK.	–
A.bF4: System Alarm 4	A failure occurred in the SERVOPACK.	–	Turn the power supply to the SERVOPACK OFF and ON again. If an alarm still occurs, the SERVOPACK may be faulty. Replace the SERVOPACK.	–
A.bF5: System Alarm 5	A failure occurred in the SERVOPACK.	–	Turn the power supply to the SERVOPACK OFF and ON again. If an alarm still occurs, the SERVOPACK may be faulty. Replace the SERVOPACK.	–
A.bF6: System Alarm 6	A failure occurred in the SERVOPACK.	–	Turn the power supply to the SERVOPACK OFF and ON again. If an alarm still occurs, the SERVOPACK may be faulty. Replace the SERVOPACK.	–
A.bF7: System Alarm 7	A failure occurred in the SERVOPACK.	–	Turn the power supply to the SERVOPACK OFF and ON again. If an alarm still occurs, the SERVOPACK may be faulty. Replace the SERVOPACK.	–
A.bF8: System Alarm 8	A failure occurred in the SERVOPACK.	–	Turn the power supply to the SERVOPACK OFF and ON again. If an alarm still occurs, the SERVOPACK may be faulty. Replace the SERVOPACK.	–

Continued from previous page.

Alarm Number: Alarm Name	Possible Cause	Confirmation	Correction	Reference
A.C10: Servomotor Out of Control (Detected when the servo is turned ON.)	The order of phases U, V, and W in the motor wiring is not correct.	Check the Servomotor wiring.	Make sure that the Servomotor is correctly wired.	–
	There is an error in the setting of Pn080 = n.□□X□ (Motor Phase Selection).	Check the setting of Pn080 = n.□□X□.	Set Pn080 = n.□□X□ to an appropriate value.	*1
	A failure occurred in the encoder.	–	If the motor wiring is correct and an alarm still occurs after turning the power supply OFF and ON again, the Servomotor or linear encoder may be faulty. Replace the Servomotor or linear encoder.	–
	A failure occurred in the SERVOPACK.	–	Turn the power supply to the SERVOPACK OFF and ON again. If an alarm still occurs, the SERVOPACK may be faulty. Replace the SERVOPACK.	–
A.C20: Phase Detection Error	The linear encoder signal level is too low.	Check the voltage of the linear encoder signal.	Fine-tune the mounting of the scale head. Or, replace the linear encoder.	–
	The count-up direction of the linear encoder does not match the forward direction of the Moving Coil in the motor.	Check the setting of Pn080 = n.□□X□ (Motor Phase Selection). Check the installation orientation for the linear encoder and Moving Coil.	Change the setting of Pn080 = n.□□X□. Correctly reinstall the linear encoder or Moving Coil.	*1
	The polarity sensor signal is being affected by noise.	–	Correct the FG wiring. Implement countermeasures against noise for the polarity sensor wiring.	–
A.C21: Polarity Sensor Error	The polarity sensor is protruding from the Magnetic Way of the motor.	Check the polarity sensor.	Correctly reinstall the Moving Coil or Magnetic Way of the motor.	–
	The setting of Pn282 (Linear Encoder Pitch) is not correct.	Check the setting of Pn282 (Linear Encoder Pitch).	Check the specifications of the linear encoder and set a correct value.	*1
	The polarity sensor is not wired correctly.	Check the wiring of the polarity sensor.	Correct the wiring of the polarity sensor.	–
	The polarity sensor failed.	–	Replace the polarity sensor.	–
A.C22: Phase Information Disagreement	The SERVOPACK phase information is different from the linear encoder phase information.	–	Perform polarity detection.	*1

8.1 Alarm Displays

8.1.2 Troubleshooting Alarms

Continued from previous page.

Alarm Number: Alarm Name	Possible Cause	Confirmation	Correction	Reference
A.C50: Polarity Detection Failure	The parameter settings are not correct.	Check the linear encoder specifications and feedback signal status.	The settings of Pn282 (Linear Encoder Pitch) and Pn080 = n.□□X□ (Motor Phase Selection) may not match the installation. Set the parameters to correct values.	*1
	There is noise on the scale signal.	Check to make sure that the frame grounds of the Serial Converter Unit and Servomotor are connected to the FG terminal on the SERVOPACK and that the FG terminal on the SERVOPACK is connected to the frame ground on the power supply. And, confirm that the shield is properly processed on the Linear Encoder Cable. Check to see if the detection reference is repeatedly output in one direction.	Implement appropriate countermeasures against noise for the Linear Encoder Cable.	-
	An external force was applied to the Moving Coil of the motor.	-	The polarity cannot be properly detected if the detection reference is 0 and the speed feedback is not 0 because of an external force, such as cable tension, applied to the Moving Coil. Implement measures to reduce the external force so that the speed feedback goes to 0. If the external force cannot be reduced, increase the setting of Pn481 (Polarity Detection Speed Loop Gain).	-
	The linear encoder resolution is too low.	Check the linear encoder scale pitch to see if it is within 100 μm.	If the linear encoder scale pitch is 100 μm or higher, the SERVOPACK cannot detect the correct speed feedback. Use a linear encoder scale pitch with higher resolution. (We recommend a pitch of 40 μm or less.) Or, increase the setting of Pn485 (Polarity Detection Reference Speed). However, increasing the setting of Pn485 will increase the Servomotor movement range that is required for polarity detection.	-
A.C51: Overtravel Detected during Polarity Detection	The overtravel signal was detected during polarity detection.	Check the overtravel position.	Wire the overtravel signals. Execute polarity detection at a position where an overtravel signal would not be detected.	*1

Continued from previous page.

Alarm Number: Alarm Name	Possible Cause	Confirmation	Correction	Reference
A.C52: Polarity Detection Not Completed	The servo was turned ON under the following circumstances. <ul style="list-style-type: none"> When an absolute scale was in use When polarity detection was not completed 	–	Execute polarity detection (with the SigmaWin+ or Digital Operator, Fn080).	*1
A.C53: Out of Range of Motion for Polar- ity Detection	The travel distance exceeded the setting of Pn48E (Polarity Detection Range) in the middle of detection.	–	Increase the setting of Pn48E (Polarity Detection Range). Or, increase the setting of Pn481 (Polarity Detection Speed Loop Gain).	–
A.C54: Polarity Detection Failure 2	An external force was applied to the Servomotor.	–	Increase the setting of Pn495 (Polarity Detection Confirmation Force Reference). Increase the setting of Pn498 (Polarity Detection Allowable Error Range). Increasing the allowable error will also increase the motor temperature.	–
A.C80: Encoder Clear Error or Multiturn Limit Setting Error	A failure occurred in the encoder.	–	Turn the power supply to the SERVOPACK OFF and ON again. If an alarm still occurs, the Servomotor or linear encoder may be faulty. Replace the Servomotor or linear encoder.	–
	A failure occurred in the SERVOPACK.	–	Turn the power supply to the SERVOPACK OFF and ON again. If an alarm still occurs, the SERVOPACK may be faulty. Replace the SERVOPACK.	–

8.1 Alarm Displays

8.1.2 Troubleshooting Alarms

Continued from previous page.

Alarm Number: Alarm Name	Possible Cause	Confirmation	Correction	Reference
A.C90: Encoder Commu- nications Error	There is a faulty contact in the connector or the connector is not wired correctly for the encoder.	Check the condition of the encoder connector.	Reconnect the encoder connector and check the encoder wiring.	*1
	There is a cable disconnection or short-circuit in the encoder. Or, the cable impedance is outside the specified values.	Check the condition of the Encoder Cable.	Use the Encoder Cable within the specified specifications.	-
	One of the following has occurred: corrosion caused by improper temperature, humidity, or gas, a short-circuit caused by entry of water drops or cutting oil, or faulty contact in connector caused by vibration.	Check the operating environment.	Improve the operating environmental, and replace the cable. If the alarm still occurs, replace the SERVOPACK.	*1
	A malfunction was caused by noise.	-	Correct the wiring around the encoder by separating the Encoder Cable from the Servomotor Main Circuit Cable or by grounding the encoder.	*1
	A failure occurred in the SERVOPACK.	-	Connect the Servomotor to another SERVOPACK, and turn ON the control power supply. If no alarm occurs, the SERVOPACK may be faulty. Replace the SERVOPACK.	-
A.C91: Encoder Commu- nications Posi- tion Data Acceleration Rate Error	Noise entered on the signal lines because the Encoder Cable is bent or the sheath is damaged.	Check the condition of the Encoder Cable and connectors.	Check the Encoder Cable to see if it is installed correctly.	*1
	The Encoder Cable is bundled with a high-current line or installed near a high-current line.	Check the installation condition of the Encoder Cable.	Confirm that there is no surge voltage on the Encoder Cable.	-
	There is variation in the FG potential because of the influence of machines on the Servomotor side, such as a welder.	Check the installation condition of the Encoder Cable.	Properly ground the machine to separate it from the FG of the encoder.	-

Continued from previous page.

Alarm Number: Alarm Name	Possible Cause	Confirmation	Correction	Reference
A.C92: Encoder Commu- nications Timer Error	Noise entered on the signal line from the encoder.	–	Implement countermeasures against noise for the encoder wiring.	*1
	Excessive vibration or shock was applied to the encoder.	Check the operating conditions.	Reduce machine vibration. Correctly install the Servomotor or linear encoder.	–
	A failure occurred in the encoder.	–	Turn the power supply to the SERVOPACK OFF and ON again. If an alarm still occurs, the Servomotor or linear encoder may be faulty. Replace the Servomotor or linear encoder.	–
	A failure occurred in the SERVOPACK.	–	Turn the power supply to the SERVOPACK OFF and ON again. If an alarm still occurs, the SERVOPACK may be faulty. Replace the SERVOPACK.	–
A.CA0: Encoder Parameter Error	A failure occurred in the encoder.	–	Turn the power supply to the SERVOPACK OFF and ON again. If an alarm still occurs, the Servomotor or linear encoder may be faulty. Replace the Servomotor or linear encoder.	–
	A failure occurred in the SERVOPACK.	–	Turn the power supply to the SERVOPACK OFF and ON again. If an alarm still occurs, the SERVOPACK may be faulty. Replace the SERVOPACK.	–

8.1 Alarm Displays

8.1.2 Troubleshooting Alarms

Continued from previous page.

Alarm Number: Alarm Name	Possible Cause	Confirmation	Correction	Reference
A.Cb0: Encoder Echoback Error	The encoder is wired incorrectly or there is faulty contact.	Check the wiring of the encoder.	Make sure that the encoder is correctly wired.	*1
	The specifications of the Encoder Cable are not correct and noise entered on it.	–	Use a shielded twisted-pair wire cable or a screened twisted-pair cable with conductors of at least 0.12 mm ² .	–
	The Encoder Cable is too long and noise entered on it.	–	<ul style="list-style-type: none"> Rotary Servomotors: The Encoder Cable wiring distance must be 50 m max. Linear Servomotors: The Encoder Cable wiring distance must be 20 m max. 	–
	There is variation in the FG potential because of the influence of machines on the Servomotor side, such as a welder.	Check the condition of the Encoder Cable and connectors.	Properly ground the machine to separate it from the FG of the encoder.	–
	Excessive vibration or shock was applied to the encoder.	Check the operating conditions.	Reduce machine vibration. Correctly install the Servomotor or linear encoder.	–
	A failure occurred in the encoder.	–	Turn the power supply to the SERVOPACK OFF and ON again. If an alarm still occurs, the Servomotor or linear encoder may be faulty. Replace the Servomotor or linear encoder.	–
	A failure occurred in the SERVOPACK.	–	Turn the power supply to the SERVOPACK OFF and ON again. If an alarm still occurs, the SERVOPACK may be faulty. Replace the SERVOPACK.	–
A.CC0: Multiturn Limit Disagreement	When using a Direct Drive Servomotor, the setting of Pn205 (Multiturn Limit Setting) does not agree with the encoder.	Check the setting of Pn205.	Correct the setting of Pn205 (0 to 65,535).	*1
	The multiturn limit of the encoder is different from that of the SERVOPACK. Or, the multiturn limit of the SERVOPACK has been changed.	Check the setting of Pn205 in the SERVOPACK.	Change the setting if the alarm occurs.	*1
	A failure occurred in the SERVOPACK.	–	Turn the power supply to the SERVOPACK OFF and ON again. If an alarm still occurs, the SERVOPACK may be faulty. Replace the SERVOPACK.	–

Continued from previous page.

Alarm Number: Alarm Name	Possible Cause	Confirmation	Correction	Reference
A.CF1: Reception Failed Error in Feed- back Option Module Commu- nications	The cable between the Serial Converter Unit and SERVOPACK is not wired correctly or there is a faulty contact.	Check the wiring of the external encoder.	Correctly wire the cable between the Serial Converter Unit and SERVOPACK.	*1
	A specified cable is not being used between Serial Converter Unit and SERVOPACK.	Check the wiring specifications of the external encoder.	Use a specified cable.	-
	The cable between the Serial Converter Unit and SERVOPACK is too long.	Measure the length of the cable that connects the Serial Converter Unit.	The length of the cable between the Serial Converter Unit and SERVOPACK must be 20 m or less.	-
	The sheath on cable between the Serial Converter Unit and SERVOPACK is broken.	Check the cable that connects the Serial Converter Unit.	Replace the cable between the Serial Converter Unit and SERVOPACK.	-
A.CF2: Timer Stopped Error in Feed- back Option Module Commu- nications	Noise entered the cable between the Serial Converter Unit and SERVOPACK.	-	Correct the wiring around the Serial Converter Unit, e.g., separate I/O signal lines from the Main Circuit Cables or ground.	-
	A failure occurred in the Serial Converter Unit.	-	Replace the Serial Converter Unit.	-
	A failure occurred in the SERVOPACK.	-	Replace the SERVOPACK.	-
A.d00: Position Deviation Overflow (The setting of Pn520 (Excessive Position Deviation Alarm Level) was exceeded by the position deviation while the servo was ON.)	The Servomotor U, V, and W wiring is not correct.	Check the wiring of the Servomotor's Main Circuit Cables.	Make sure that there are no faulty contacts in the wiring for the Servomotor and encoder.	-
	The position command speed is too fast.	Reduce the position command speed and try operating the SERVOPACK.	Reduce the position reference speed or the reference acceleration rate, or reconsider the electronic gear ratio.	*1
	The acceleration of the position reference is too high.	Reduce the reference acceleration and try operating the SERVOPACK.	Reduce the acceleration of the position reference with one of the following methods. • Reduce the acceleration rate (ACC) and deceleration rate (DEC) in the program table. • Reduce the settings of Pn63E (Acceleration Rate) and Pn640 (Deceleration Rate).	*1
	The setting of Pn520 (Excessive Position Deviation Alarm Level) is too low for the operating conditions.	Check Pn520 (Excessive Position Deviation Alarm Level) to see if it is set to an appropriate value.	Optimize the setting of Pn520.	*1
	A failure occurred in the SERVOPACK.	-	Turn the power supply to the SERVOPACK OFF and ON again. If an alarm still occurs, the SERVOPACK may be faulty. Replace the SERVOPACK.	-

8.1 Alarm Displays

8.1.2 Troubleshooting Alarms

Continued from previous page.

Alarm Number: Alarm Name	Possible Cause	Confirmation	Correction	Reference
A.d01: Position Deviation Overflow Alarm at Servo ON	The servo was turned ON after the position deviation exceeded the setting of Pn526 (Excessive Position Deviation Alarm Level at Servo ON) while the servo was OFF.	Check the position deviation while the servo is OFF.	Optimize the setting of Pn526 (Excessive Position Deviation Alarm Level at Servo ON).	
A.d02: Position Deviation Overflow Alarm for Speed Limit at Servo ON	If position deviation remains in the deviation counter, the setting of Pn529 or Pn584 (Speed Limit Level at Servo ON) limits the speed when the servo is turned ON. This alarm occurs if a position reference is input and the setting of Pn520 (Excessive Position Deviation Alarm Level) is exceeded.	–	Optimize the setting of Pn520 (Excessive Position Deviation Alarm Level). Or, adjust the setting of Pn529 or Pn584 (Speed Limit Level at Servo ON).	*1
A.d10: Motor-Load Position Deviation Overflow	The motor direction and external encoder installation orientation are backward.	Check the motor direction and the external encoder installation orientation.	Install the external encoder in the opposite direction, or change the setting of Pn002 = n.X□□□ (External Encoder Usage) to reverse the direction.	*1
	There is an error in the connection between the load (e.g., stage) and external encoder coupling.	Check the coupling of the external encoder.	Check the mechanical coupling.	–
A.d30: Position Data Overflow	The position data exceeded $\pm 1,879,048,192$.	Check the input reference pulse counter.	Reconsider the operating specifications.	–
A.E71: Safety Option Module Detection Failure	The connection between the SERVO-PACK and the safety option module is faulty.	Check the connection between the SERVO-PACK and the safety option module.	Correctly connect the safety option module.	–
	The safety option module was disconnected.	–	Execute Fn014 (Resetting configuration error of option module) using the digital operator or SigmaWin+ and turn the power supply OFF and then ON again.	*1
	A safety option module fault occurred.	–	Replace the safety option module.	–
	A failure occurred in the SERVOPACK.	–	Replace the SERVOPACK.	–

Continued from previous page.

Alarm Number: Alarm Name	Possible Cause	Confirmation	Correction	Reference
A.E72: Feedback Option Module Detection Failure	There is a faulty connection between the SERVOPACK and the Feedback Option Module.	Check the connection between the SERVOPACK and the Feedback Option Module.	Correctly connect the Feedback Option Module.	–
	The Feedback Option Module was disconnected.	–	Reset the Option Module configuration error and turn the power supply to the SERVOPACK OFF and ON again.	*1
	A failure occurred in the Feedback Option Module.	–	Replace the Feedback Option Module.	–
	A failure occurred in the SERVOPACK.	–	Replace the SERVOPACK.	–
A.E74: Unsupported Safety Option Module	A safety option module fault occurred.	–	Replace the safety option module.	–
	A unsupported safety option module was connected.	–	Connect a compatible safety option module.	–
A.E75*3: Unsupported Feedback Option Module	A feedback option module fault occurred.	–	Replace the feedback option module.	–
	A unsupported feedback option module was connected.	Refer to the catalog of the connected feedback option module or the manual of the SERVOPACK.	Connect a compatible feedback option module.	–
A.Eb1: Safety Function Signal Input Timing Error	The delay between activation of the /HWBB1 and /HWBB2 input signals for the HWBB was ten second or longer.	Measure the time delay between the /HWBB1 and /HWBB2 signals.	The output signal circuits or devices for /HWBB1 and /HWBB2 or the SERVOPACK input signal circuits may be faulty. Alternatively, the input signal cables may be disconnected. Check to see if any of these items are faulty or have been disconnected.	–
	A failure occurred in the SERVOPACK.	–	Replace the SERVOPACK.	–
A.EC8: Gate Drive Error 1 (An error occurred in the gate drive circuit.)	A failure occurred in the SERVOPACK.	–	Turn the power supply to the SERVOPACK OFF and ON again. If an alarm still occurs, the SERVOPACK may be faulty. Replace the SERVOPACK.	–
A.EC9: Gate Drive Error 2 (An error occurred in the gate drive circuit.)				
A.EF9: INDEXER Alarm	An alarm occurred in the INDEXER.	Use the SigmaWin+ to identify the INDEXER alarm.	Use the correction for the INDEXER alarm.	page 8-36

8.1 Alarm Displays

8.1.2 Troubleshooting Alarms

Continued from previous page.

Alarm Number: Alarm Name	Possible Cause	Confirmation	Correction	Reference
A.F10: Power Supply Line Open Phase (The voltage was low for more than one second for phase R, S, or T when the main power supply was ON.)	The three-phase power supply wiring is not correct.	Check the power supply wiring.	Make sure that the power supply is correctly wired.	*1
	The three-phase power supply is unbalanced.	Measure the voltage for each phase of the three-phase power supply.	Balance the power supply by changing phases.	-
	A single-phase power supply was input without specifying a signal-phase AC power supply input (Pn00B = n.□1□□).	Check the power supply and the parameter setting.	Match the parameter setting to the power supply.	*1
	A failure occurred in the SERVOPACK.	-	Turn the power supply to the SERVOPACK OFF and ON again. If an alarm still occurs, the SERVOPACK may be faulty. Replace the SERVOPACK.	-
A.F50: Servomotor Main Circuit Cable Disconnection (The Servomotor did not operate or power was not supplied to the Servomotor even though the /S-ON signal was input when the Servomotor was ready to receive it.)	A failure occurred in the SERVOPACK.	-	The SERVOPACK may be faulty. Replace the SERVOPACK.	-
	The wiring is not correct or there is a faulty contact in the motor wiring.	Check the wiring.	Make sure that the Servomotor is correctly wired.	*1
FL-1*5: System Alarm FL-2*5: System Alarm FL-3*5: System Alarm FL-4*5: System Alarm FL-5*5: System Alarm FL-6*5: System Alarm	A failure occurred in the SERVOPACK.	-	Turn the power supply to the SERVOPACK OFF and ON again. If an alarm still occurs, the SERVOPACK may be faulty. Replace the SERVOPACK.	-
CPF00: Digital Operator Communications Error 1	There is a faulty contact between the Digital Operator and the SERVOPACK.	Check the connector contact.	Disconnect the connector and insert it again. Or, replace the cable.	-
	A malfunction was caused by noise.	-	Keep the Digital Operator or the cable away from sources of noise.	-

Continued from previous page.

Alarm Number: Alarm Name	Possible Cause	Confirmation	Correction	Reference
CPF01: Digital Operator Communications Error 2	A failure occurred in the Digital Operator.	—	Disconnect the Digital Operator and then connect it again. If an alarm still occurs, the Digital Operator may be faulty. Replace the Digital Operator.	—
	A failure occurred in the SERVOPACK.	—	Turn the power supply to the SERVOPACK OFF and ON again. If an alarm still occurs, the SERVOPACK may be faulty. Replace the SERVOPACK.	—

*1. Refer to the following manual for details.

 Σ -7-Series Σ -7S SERVOPACK with Analog Voltage/Pulse Train References Product Manual (Manual No.: SIEP S800001 26)

*2. Detection Conditions

• Rotary Servomotor

If either of the following conditions is detected, an alarm will occur.

$$\bullet \text{ Pn533 [min}^{-1}\text{]} \times \frac{\text{Encoder resolution}}{6 \times 10^5} \leq \frac{\text{Pn20E}}{\text{Pn210}}$$

$$\bullet \text{ Maximum motor speed [min}^{-1}\text{]} \times \frac{\text{Encoder resolution}}{\text{Approx. } 3.66 \times 10^{12}} \geq \frac{\text{Pn20E}}{\text{Pn210}}$$

• Linear Servomotor

If either of the following conditions is detected, an alarm will occur.

$$\bullet \frac{\text{Pn585 [mm/s]}}{\text{Linear encoder pitch [\mu m]}} \times \frac{\text{Resolution of Serial Converter Unit}}{10} \leq \frac{\text{Pn20E}}{\text{Pn210}}$$

$$\bullet \frac{\text{Pn385 [100 mm/s]}}{\text{Linear encoder pitch [\mu m]}} \times \frac{\text{Resolution of Serial Converter Unit}}{\text{Approx. } 6.10 \times 10^5} \geq \frac{\text{Pn20E}}{\text{Pn210}}$$

*3. Detection Conditions

• Rotary Servomotor

If either of the following conditions is detected, an alarm will occur.

$$\bullet \text{ Rated motor speed [min}^{-1}\text{]} \times 1/3 \times \frac{\text{Encoder resolution}}{6 \times 10^5} \leq \frac{\text{Pn20E}}{\text{Pn210}}$$

$$\bullet \text{ Maximum motor speed [min}^{-1}\text{]} \times \frac{\text{Encoder resolution}}{\text{Approx. } 3.66 \times 10^{12}} \geq \frac{\text{Pn20E}}{\text{Pn210}}$$

• Linear Servomotor

If either of the following conditions is detected, an alarm will occur.

$$\bullet \frac{\text{Rated motor speed [mm/s]} \times 1/3}{\text{Linear encoder pitch [\mu m]}} \times \frac{\text{Resolution of Serial Converter Unit}}{10} \leq \frac{\text{Pn20E}}{\text{Pn210}}$$

$$\bullet \frac{\text{Pn385 [100 mm/s]}}{\text{Linear encoder pitch [\mu m]}} \times \frac{\text{Resolution of Serial Converter Unit}}{\text{Approx. } 6.10 \times 10^5} \geq \frac{\text{Pn20E}}{\text{Pn210}}$$

*4. Refer to the following manual for details.

 Σ -7-Series AC Servo Drive Peripheral Device Selection Manual (Manual No.: SIEP S800001 32)

*5. These alarms are not stored in the alarm history. They are only displayed on the panel display.

8.1.3 INDEXER Alarm Displays and Troubleshooting

INDEXER alarms and corrections for them are given in the following table.

Error Number	Alarm Number	Alarm Name	Meaning	Corrective Action	Servo-motor Stop Method	Alarm Reset
E19A	A.EF9	Program Table Checksum Alarm (Detected only when control power supply is turned ON.)	The program table stored in flash memory was not recorded properly. (This alarm can occur if the control power supply is turned OFF while the program table is being saved or initialized.)	<ul style="list-style-type: none"> Initialize the program table. (Fn063) If the problem is not solved, correct the program table. 	Gr. 1	Available* ¹
E1AA	A.EF9	Program Table Version Unmatched (Detected only when control power supply is ON.)	The combination of the firmware version and the program table version is wrong.	<ul style="list-style-type: none"> Change the firmware version. Change the program table version to match the firmware version. 	Gr. 1	Available* ¹
E1BA	A.EF9	Program Out-of-range Alarm (Detected only when control power supply is turned ON.)	A value set in the program table is not within the allowed setting range.	<ul style="list-style-type: none"> Change the firmware version. Change the program table version to match the firmware version. 	Gr. 1	Available* ¹
E1CA	A.EF9	ZONE Table Checksum Alarm (Detected only when control power supply is turned ON.)	The ZONE table stored in flash memory was not recorded properly. (This alarm can occur if the control power supply is turned OFF while the ZONE table is being saved or initialized.)	<ul style="list-style-type: none"> Initialize the ZONE table. (Fn064) If the problem is not solved, correct the ZONE table. 	Gr. 1	Available* ²
E1DA	A.EF9	ZONE Table Version Unmatched (Detected only when control power supply is turned ON.)	The combination of the firmware version and the ZONE table version is wrong.	<ul style="list-style-type: none"> Change the firmware version. Change the ZONE table version to match the firmware version. 	Gr. 1	Available* ²
E1EA	A.EF9	ZONE Table Out-of-range Alarm (Detected only when control power supply is turned ON.)	A value set in the ZONE table is not within the allowed setting range.	<ul style="list-style-type: none"> Change the firmware version. Change the ZONE table version to match the firmware version. 	Gr. 1	Available* ²

Continued on next page.

Continued from previous page.

Error Number	Alarm Number	Alarm Name	Meaning	Corrective Action	Servo-motor Stop Method	Alarm Reset
E1FA	A.EF9	JOG Speed Table Check-sum Alarm (Detected only when control power supply is turned ON.)	The JOG speed table stored in flash memory was not recorded properly. (This alarm can occur if the control power supply is turned OFF while the JOG speed table is being saved or initialized.)	<ul style="list-style-type: none"> Initialize the JOG speed table. (Fn065) If the problem is not solved, correct the JOG speed table. 	Gr. 1	Available* ³
E21A	A.EF9	JOG Speed Table Version Unmatched (Detected only when control power supply is turned ON.)	The combination of the firmware version and the JOG speed table version is wrong.	<ul style="list-style-type: none"> Change the firm-ware version. Change the JOG speed table version to match the firm-ware version. 	Gr. 1	Available* ³
E22A	A.EF9	JOG Speed Table Out-of-range Alarm (Detected only when control power supply is turned ON.)	A value set in the JOG speed table is not within the allowed setting range.	<ul style="list-style-type: none"> Change the firm-ware version. Change the JOG speed table version to match the firm-ware version. 	Gr. 1	Available* ³
E23A	A.EF9	Insufficient Registration Distance Alarm	The registration distance was shorter than the deceleration distance when the /RGRT signal went ON to start registration operation. (The current position will exceed the position specified by registration.)	Either increase the registration distance or reduce the deceleration distance (increase the deceleration rate). Registration distance: RDST in the program table Deceleration Rate: Pn640	Gr. 1	Available

*1. These alarms can be reset, but a Canceled Program Table Error (E44E) will occur the next time you attempt to start program table operation, so program table operation will not be possible.

*2. These alarms can be reset, but it is possible that the ZONE signals (POUT0 to POUT4) will be output incorrectly. When using the ZONE table, correct the ZONE table without resetting.

*3. These alarms can be reset, but a Canceled JOG Speed Table Error (E46E) will occur the next time you attempt to start JOG speed table operation, so JOG speed table operation will not be possible.

8.2 Warning Displays

Warnings are displayed to warn you before an alarm occurs. If a warning occurs in the SERVOPACK, the status is displayed as described below.

◆ Status Display

SERVOPACK Panel Display	The alarm number will be displayed. Refer to the following manual for details.  Σ -7-Series Σ -7S SERVOPACK with Analog Voltage/Pulse Train References Product Manual (Manual No.: SIEP S800001 26)
Digital Operator	When a warning occurs, the warning code is displayed at the top left of the screen.
ALM Signal	No change
/WARN Signal	Turns ON.

A list of warnings and the causes of and corrections for warnings are given below.

8.2.1 List of Warnings

This section gives the warning names, warning meanings, and warning code outputs in order of the warning numbers.

List of Warnings

Warning Number	Warning Name	Meaning	Warning Code Output		
			/ALO1	/ALO2	/ALO3
A.900	Position Deviation Overflow	The position deviation exceeded the parameter settings (Pn520 × Pn51E/100).	H	H	H
A.901	Position Deviation Overflow Alarm at Servo ON	The position deviation exceeded the parameter settings (Pn526 × Pn528/100) when the servo was turned ON.			
A.910	Overload	This warning occurs before an overload alarm (A.710 or A.720) occurs. If the warning is ignored and operation is continued, an alarm may occur.	L	H	H
A.911	Vibration	Abnormal vibration was detected during motor operation. The detection level is the same as A.520. Set whether to output an alarm or a warning by setting Pn310 (Vibration Detection Switch).			

Continued on next page.

Continued from previous page.

Warning Number	Warning Name	Meaning	Warning Code Output		
			/ALO1	/ALO2	/ALO3
A.912	Internal Temperature Warning 1 (Control Board Temperature Error)	The surrounding temperature of the control PCB is abnormal.			
A.913	Internal Temperature Warning 2 (Power Board Temperature Error)	The surrounding temperature of the power PCB is abnormal.			
A.920	Regenerative Overload	This warning occurs before an A.320 alarm (Regenerative Overload) occurs. If the warning is ignored and operation is continued, an alarm may occur.	H	L	H
A.921	Dynamic Brake Overload	This warning occurs before an A.731 alarm (Dynamic Brake Overload) occurs. If the warning is ignored and operation is continued, an alarm may occur.			
A.923	SERVOPACK Built-in Fan Stopped	The fan inside the SERVOPACK stopped.			
A.930	Absolute Encoder Battery Error	This warning occurs when the voltage of absolute encoder's battery is low.	L	L	H
A.942	Speed Ripple Compensation Information Disagreement	The speed ripple compensation information stored in the encoder does not agree with the speed ripple compensation information stored in the SERVOPACK.	H	H	L
A.971	Undervoltage	This warning occurs before an A.410 alarm (Undervoltage) occurs. If the warning is ignored and operation is continued, an alarm may occur.	L	L	L
A.9A0	Overtravel	Overtravel was detected while the servo was ON.	H	L	L
A.9b0	Preventative Maintenance Warning	One of the consumable parts has reached the end of its service life.	H	L	H
A.9F9	INDEXER Warning	A warning occurred in the INDEXER.	L	H	H

Note: 1. A warning code is not output unless you set Pn001 to n.1□□□ (Output both alarm codes and warning codes).

2. Use Pn008 = n.□X□□ (Warning Detection Selection) to control warning detection. However, the following warnings are not affected by the setting of Pn008 = n.□X□□ and other parameter settings are required in addition to Pn008 = n.□X□□.

Warning	Parameters That Must Be Set to Select Warning Detection	Reference
A.911	Pn310 = n.□□□X (Vibration Detection Setting)	–
A.930	Pn008 = n.□□□X (Low Battery Voltage Alarm/Warning Selection)	–
A.942	Pn423 = n.□□□X (Speed Ripple Compensation Information Disagreement Warning Detection Selection)	–
A.971	Pn008 = n.□□□X (Low Battery Voltage Alarm/Warning Selection) (Not affected by the setting of Pn008 = n.□X□□.)	–
A.9A0	Pn00D = n.X□□□ (Overtravel Warning Detection Selection) (Not affected by the setting of Pn008 = n.□X□□.)	–
A.9b0	Pn00F = n.□□□X (Preventative Maintenance Selection)	–

8.2.2 Troubleshooting Warnings

The causes of and corrections for the warnings are given in the following table. Contact your Yaskawa representative if you cannot solve a problem with the correction given in the table.

Warning Number: Warning Name	Possible Cause	Confirmation	Correction	Reference
A.900: Position Deviation Overflow	The Servomotor U, V, and W wiring is not correct.	Check the wiring of the Servomotor's Main Circuit Cables.	Make sure that there are no faulty connections in the wiring for the Servomotor and encoder.	-
	A SERVOPACK gain is too low.	Check the SERVO-PACK gains.	Increase the servo gain, e.g., by using autotuning without a host reference.	-
	The acceleration of the position reference is too high.	Reduce the reference acceleration and try operating the SERVO-PACK.	Reduce the acceleration of the position reference with one of the following methods. <ul style="list-style-type: none"> • Reduce the acceleration rate (ACC) and deceleration rate (DEC) in the program table. • Reduce the settings of Pn63F (Acceleration Rate) and Pn640 (Deceleration Rate). 	-
	The excessive position deviation alarm level (Pn520 × Pn51E/100) is too low for the operating conditions.	Check excessive position deviation alarm level (Pn520 × Pn51E/100) to see if it is set to an appropriate value.	Optimize the settings of Pn520 and Pn51E.	-
	A failure occurred in the SERVO-PACK.	-	Turn the power supply to the SERVOPACK OFF and ON again. If an alarm still occurs, the SERVOPACK may be faulty. Replace the SERVOPACK.	-
A.901: Position Deviation Overflow Alarm at Servo ON	The position deviation exceeded the parameter settings (Pn526 × Pn528/100) when the servo was turned ON.	-	Optimize the setting of Pn528 (Excessive Position Error Warning Level at Servo ON).	-

Continued from previous page.

Warning Number: Warning Name	Possible Cause	Confirmation	Correction	Reference
A.910: Overload (warning before an A.710 or A.720 alarm occurs)	The wiring is not correct or there is a faulty contact in the motor or encoder wiring.	Check the wiring.	Make sure that the Servomotor and encoder are correctly wired.	-
	Operation was performed that exceeded the overload protection characteristics.	Check the motor overload characteristics and operation reference.	Reconsider the load and operating conditions. Or, increase the motor capacity.	-
	An excessive load was applied during operation because the Servomotor was not driven because of mechanical problems.	Check the operation reference and motor speed.	Remove the mechanical problem.	-
	The overload warning level (Pn52B) is not suitable.	Check that the overload warning level (Pn52B) is suitable.	Set a suitable overload warning level (Pn52B).	-
	A failure occurred in the SERVOPACK.	-	The SERVOPACK may be faulty. Replace the SERVOPACK.	-
A.911: Vibration	Abnormal vibration was detected during motor operation.	Check for abnormal motor noise, and check the speed and torque waveforms during operation.	Reduce the motor speed. Or, reduce the servo gain with custom tuning.	-
	The setting of Pn103 (Moment of Inertia Ratio) is greater than the actual moment of inertia or was greatly changed.	Check the moment of inertia ratio or mass ratio.	Set Pn103 (Moment of Inertia Ratio) to an appropriate value.	-
	The vibration detection level (Pn312 or Pn384) is not suitable.	Check that the vibration detection level (Pn312 or Pn384) is suitable.	Set a suitable vibration detection level (Pn312 or Pn384).	-

8.2 Warning Displays

8.2.2 Troubleshooting Warnings

Continued from previous page.

Warning Number: Warning Name	Possible Cause	Confirmation	Correction	Reference
A.912: Internal Temperature Warning 1 (Control Board Temperature Error)	The surrounding temperature is too high.	Check the surrounding temperature using a thermostat. Or, check the operating status with the SERVOPACK installation environment monitor.	Decrease the surrounding temperature by improving the SERVOPACK installation conditions.	–
	An overload alarm was reset by turning OFF the power supply too many times.	Check the alarm display to see if there is an overload alarm.	Change the method for resetting the alarm.	–
	There was an excessive load or operation was performed that exceeded the regenerative processing capacity.	Use the accumulated load ratio to check the load during operation, and use the regenerative load ratio to check the regenerative processing capacity.	Reconsider the load and operating conditions.	–
	The SERVOPACK installation orientation is not correct or there is insufficient space around the SERVOPACK.	Check the SERVOPACK installation conditions.	Install the SERVOPACK according to specifications.	–
	A failure occurred in the SERVOPACK.	–	The SERVOPACK may be faulty. Replace the SERVOPACK.	–
A.913: Internal Temperature Warning 2 (Power Board Temperature Error)	The surrounding temperature is too high.	Check the surrounding temperature using a thermostat. Or, check the operating status with the SERVOPACK installation environment monitor.	Decrease the surrounding temperature by improving the SERVOPACK installation conditions.	–
	An overload alarm was reset by turning OFF the power supply too many times.	Check the alarm display to see if there is an overload alarm.	Change the method for resetting the alarm.	–
	There was an excessive load or operation was performed that exceeded the regenerative processing capacity.	Use the accumulated load ratio to check the load during operation, and use the regenerative load ratio to check the regenerative processing capacity.	Reconsider the load and operating conditions.	–
	The SERVOPACK installation orientation is not correct or there is insufficient space around the SERVOPACK.	Check the SERVOPACK installation conditions.	Install the SERVOPACK according to specifications.	–
	A failure occurred in the SERVOPACK.	–	The SERVOPACK may be faulty. Replace the SERVOPACK.	–

Continued from previous page.

Warning Number: Warning Name	Possible Cause	Confirmation	Correction	Reference
A.920: Regenerative Overload (warning before an A.320 alarm occurs)	The power supply voltage exceeded the specified range.	Measure the power supply voltage.	Set the power supply voltage within the specified range.	-
	There is insufficient external regenerative resistance, regenerative resistor capacity, or SERVOPACK capacity, or there has been a continuous regeneration state.	Check the operating conditions or the capacity using the SigmaJunmaSize+ Capacity Selection Software or another means.	Change the regenerative resistance value, regenerative resistance capacity, or SERVOPACK capacity. Reconsider the operating conditions using the SigmaJunmaSize+ Capacity Selection Software or other means.	-
	There was a continuous regeneration state because a negative load was continuously applied.	Check the load applied to the Servomotor during operation.	Reconsider the system including the servo, machine, and operating conditions.	-
A.921: Dynamic Brake Overload (warning before an A.731 alarm occurs)	The Servomotor was rotated by an external force.	Check the operation status.	Implement measures to ensure that the motor will not be rotated by an external force.	-
	When the Servomotor was stopped with the dynamic brake, the rotational or linear kinetic energy exceeded the capacity of the dynamic brake resistor.	Check the power consumed by the DB resistor to see how frequently the DB is being used.	Reconsider the following: <ul style="list-style-type: none"> • Reduce the Servomotor command speed. • Decrease the moment of inertia or mass. • Reduce the frequency of stopping with the dynamic brake. 	-
	A failure occurred in the SERVOPACK.	-	The SERVOPACK may be faulty. Replace the SERVOPACK.	-
A.923: SERVOPACK Built-in Fan Stopped	The fan inside the SERVOPACK stopped.	Check for foreign matter inside the SERVOPACK.	Remove foreign matter from the SERVOPACK. If an alarm still occurs, the SERVOPACK may be faulty. Replace the SERVOPACK.	-
A.930: Absolute Encoder Battery Error (The absolute encoder battery voltage was lower than the specified level.) (Detected only when an absolute encoder is con- nected.)	The battery connection is faulty or a battery is not connected.	Check the battery connection.	Correct the battery connection.	-
	The battery voltage is lower than the specified value (2.7 V).	Measure the battery voltage.	Replace the battery.	-
	A failure occurred in the SERVOPACK.	-	The SERVOPACK may be faulty. Replace the SERVOPACK.	-

8.2 Warning Displays

8.2.2 Troubleshooting Warnings

Continued from previous page.

Warning Number: Warning Name	Possible Cause	Confirmation	Correction	Reference
A.942: Speed Ripple Compensation Information Disagreement	The speed ripple compensation information stored in the encoder does not agree with the speed ripple compensation information stored in the SERVOPACK.	–	Reset the speed ripple compensation value on the SigmaWin+.	–
		–	Set Pn423 to n.□□1□ (Do not detect A.942 alarms). However, changing the setting may increase the speed ripple.	–
		–	Set Pn423 to n.□□□0 (Disable torque ripple compensation). However, changing the setting may increase the speed ripple.	–
A.971: Undervoltage	For a 200-V SERVOPACK, the AC power supply voltage dropped below 140 V.	Measure the power supply voltage.	Set the power supply voltage within the specified range.	–
	The power supply voltage dropped during operation.	Measure the power supply voltage.	Increase the power supply capacity.	–
	A momentary power interruption occurred.	Measure the power supply voltage.	If you have changed the setting of Pn509 (Momentary Power Interruption Hold Time), decrease the setting.	–
	The SERVOPACK fuse is blown out.	–	Replace the SERVOPACK and connect a reactor.	–
	A failure occurred in the SERVOPACK.	–	The SERVOPACK may be faulty. Replace the SERVOPACK.	–
A.9A0: Overtravel (Overtravel status was detected.)	Overtravel was detected while the servo was ON.	Check the status of the overtravel signals on the input signal monitor.	Even if an overtravel signal is not shown by the input signal monitor, momentary overtravel may have been detected. Take the following precautions. <ul style="list-style-type: none"> • Do not specify movements that would cause overtravel from the host controller. • Check the wiring of the overtravel signals. • Implement countermeasures against noise. 	–
A.9b0: Preventative Maintenance Warning	One of the consumable parts has reached the end of its service life.	–	Replace the part. Contact your Yaskawa representative for replacement.	–
A.9F9: INDEXER Warning	A warning occurred in the INDEXER.	Use the SigmaWin+ to identify the INDEXER warning.	Use the correction for the INDEXER warning.	page 8-45

8.2.3 INDEXER Warning Displays and Troubleshooting

INDEXER warning displays and corrections for them are given in the following table.

Error No.	Alarm Number	Error Name	Meaning	Corrective Action
E41E	A.9F9	Program Table Save Failure Error	While writing data to the flash memory, a failure occurred during one of the following operation. <ul style="list-style-type: none"> • While saving a program table by using Fn060 • While initializing a program table by using Fn063 	Repair the hardware.
E42E	A.9F9	ZONE Table Save Failure Error	While writing data to the flash memory, a failure occurred during one of the following operation. <ul style="list-style-type: none"> • While saving a ZONE table by using Fn061 • While initializing a ZONE table by using Fn064 	Repair the hardware.
E43E	A.9F9	JOG Speed Table Save Failure Error	While writing data to the flash memory, a failure occurred during one of the following operation. <ul style="list-style-type: none"> • While saving a JOG speed table by using Fn061 • While initializing a JOG speed table by using Fn065 	Repair the hardware.
E44E	A.9F9	Canceled Program Table Error	There was a request to start program table operation even though an E19A or E1BA alarm occurred when the control power supply was turned ON.	Remove the cause of the alarm.
E46E	A.9F9	Canceled JOG Speed Table Error	There was a request to start JOG speed table operation even though an E1FA or E22A alarm occurred when the control power supply was turned ON.	Remove the cause of the alarm.
E4BE	A.9F9	Moving Disabled Error due to P-OT	Travel in the forward direction was requested when P-OT was in effect. (Forward movement is disabled when P-OT (forward overtravel) is in effect.)	<ul style="list-style-type: none"> • When P-OT is being used, move to a position where the P-OT is not in effect. • When P-OT is not being used, disable P-OT in the parameter.
E4CE	A.9F9	Moving Disabled Error due to N-OT	Travel in the reverse direction was requested when N-OT was in effect. (Reverse movement is disabled when N-OT (reverse overtravel) is in effect.)	<ul style="list-style-type: none"> • When N-OT is being used, move to a position where the N-OT is not in effect. • When N-OT is not being used, disable N-OT in the parameter.

Continued from previous page.

Error No.	Alarm Number	Error Name	Meaning	Corrective Action
E4DE	A.9F9	Moving Disabled Error due to P-LS	The specified target position exceeds the position reference of forward software limit set in Pn638.	<ul style="list-style-type: none"> • Check the target position specification. • Check the forward software limit in Pn638. • Check the Moving Mode (rotational/linear coordinates) (Pn637= n.□□□X) • If the software limits are not being used, select rotational coordinates with Pn637= n.□□□X (Moving Mode) or disable the software limits by setting Pn638 = Pn63A = 0.
E4EE	A.9F9	Moving Disabled Error due to N-LS	The specified target position exceeds the position reference of reverse software limit set in Pn63A.	<ul style="list-style-type: none"> • Check the target position specification. • Check the reverse software limit in Pn63A. • Check the setting of the Moving Mode (rotational/linear coordinates) (Pn637= n.□□□X). • If the software limits are not being used, select rotational coordinates with Pn637 = n.□□□X (Moving Mode) or disable the software limits by setting Pn638 = Pn63A = 0.

Continued from previous page.

Error No.	Alarm Number	Error Name	Meaning	Corrective Action
E4FE	A.9F9	Position Reference Out-of-range Error	The Moving Mode is set to rotational coordinates (i.e., Pn637 is not set to n.□□□0) and the target position designation exceeded the position range setting (Pn638 and Pn63A).	<ul style="list-style-type: none"> • Check the target position specification. • Check the positioning range set with Pn638 and Pn63A. • Check the setting of the Moving Mode (rotational/linear coordinates) (Pn637= n.□□□X).
E53E	A.9F9	Move Reference Duplication Error	There was a new move reference requested even though the system was already moving in a positioning or other traveling operation.	<ul style="list-style-type: none"> • Send the next move reference request only after the current movement is completed. • Specify STOP in the target position specification (POS) with the program table.
E54E	A.9F9	Servo ON Incomplete Error	<p>The servo is not ON. There was a positioning request or other move reference request in servo OFF status. The servo went OFF during program table operation. (Program table operation will be interrupted while just the step that was being executed is canceled. (If LOOP ≠ 1, the first LOOP is canceled.))</p>	Request positioning and other operations after turning ON the servo by turning ON the /S-ON signal or setting the /S-ON signal to always be ON. Either just cancel the operation with the /PGM-RES signal or turn ON the servo and restart with the /START-STOP signal.
			<p>An E23A alarm (Insufficient Registration Distance Alarm) occurred.</p>	Increase the registration distance or shorten the deceleration distance (i.e., increase the deceleration rate). Registration distance: RDST in the program table Deceleration rate: Pn640

Continued from previous page.

Error No.	Alarm Number	Error Name	Meaning	Corrective Action
E55E	A.9F9	Servo ON Failure Error	<ul style="list-style-type: none"> The motor is rotating during servo ON execution. The main power supply went OFF during servo ON execution. Hard wire base block status (HWBB status) 	<ul style="list-style-type: none"> Turn the servo ON when the motor is stopped. Turn ON the /HWBB1 and /HWBB2 signals. Then turn OFF the /S-ON signal to first turn OFF the servo and then turn ON the servo again.
E58E	A.9F9	Data Out-of-range Error	The specified setting was incorrect in a parameter or program table write command.	Check the setting.
E5DE	A.9F9	Homing Method Unspecified Error	The homing method is not specified. Starting homing was requested by turning ON the /HOME signal without setting the homing method.	Specify the homing method with Pn642 = n.□□□X.
E5EE	A.9F9	Execution Disabled during Program Table Operation Error	<ul style="list-style-type: none"> There was a request to execute a process that is not allowed during program table operation while program table operation was in progress or on hold. There was an attempt to change the program table while program table operation was in progress or on hold. 	Request execution of the process again after canceling program table operation by turning the /PGMRES signal ON.
E5FE	A.9F9	Session Conflict Error	There was a request that could not be executed at the same time as the function that was being executed. Example: There was a request to start program table operation while the program table was being initialized.	Execute the operation again after the execution of the current function is completed.
E61E	A.9F9	Encoder Mismatch Error	Homing start was requested (i.e., the /HOME signal was turned ON) when an absolute encoder is connected.	<ul style="list-style-type: none"> Check the Encoder. Set Pn002 to n.□1□□ (Use the absolute encoder as an incremental encoder).
E63E	A.9F9	Continuous Stop Execution Disabled Error	<p>An attempt was made to execute a continuous stop under conditions where it could not be executed.</p> <p>Examples:</p> <ul style="list-style-type: none"> The coordinates have been set to linear moving method. The immediately-preceding table target position is not ±INFINITE. The immediately-preceding table target position is ±INFINITE, but the registration distance is set. A value other than 1 has been set for the execution count. 	Execute a continuous stop under conditions where it can be executed.

8.3

Troubleshooting Based on the Operation and Conditions of the Servomotor

This section provides troubleshooting based on the operation and conditions of the Servomotor, including causes and corrections.

Turn OFF the Servo System before troubleshooting the items shown in bold lines in the table.

Problem	Possible Cause	Confirmation	Correction	Reference
Servomotor Does Not Start	The control power supply is not turned ON.	Measure the voltage between control power supply terminals.	Correct the wiring so that the control power supply is turned ON.	-
	The main circuit power supply is not turned ON.	Measure the voltage across the main circuit power input terminals.	Correct the wiring so that the main circuit power supply is turned ON.	-
	The I/O signal connector (CN1) pins are not wired correctly or are disconnected.	Check the wiring condition of the I/O signal connector (CN1) pins.	Correct the wiring of the I/O signal connector (CN1) pins.	-
	The wiring for the Servomotor Main Circuit Cables or Encoder Cable is disconnected.	Check the wiring conditions.	Wire the cable correctly.	-
	There is an overload on the Servomotor.	Operate the Servomotor with no load and check the load status.	Reduce the load or replace the Servomotor with a larger capacity.	-
	The type of encoder that is being used does not agree with the setting of Pn002 = n.X□□ (Encoder Usage).	Check the type of the encoder that is being used and the setting of Pn002 = n.X□□.	Set Pn002 = n.X□□ according to the type of the encoder that is being used.	-
	Settings for input signals Pn630 to Pn64D are incorrect.	Check settings of input signals Pn630 to Pn64D.	Correct the settings of input signals Pn630 to Pn64D.	-
	The /S-ON (Servo ON) signal was not received.	Check the commands sent from the host controller.	Turn ON the /S-ON signal from the host controller.	-
	The P-OT (Forward Drive Prohibit) or N-OT (Reverse Drive Prohibit) signal is still OFF.	Check the P-OT and N-OT signals.	Turn ON the P-OT or N-OT signal.	-
	The current position of the servomotor is outside the software limit setting range.	Check for INDEXER errors.	Check the motor position and software limit setting (Pn638 and Pn63A), then move the servomotor into the software limit setting range.	-
	There is no position reference, or it is incorrect.	Check for INDEXER errors.	Set the program table correctly.	-
	The safety input signals (/HWBB1 or /HWBB2) were not turned ON.	Check the /HWBB1 and /HWBB2 input signals.	Turn ON the /HWBB1 and /HWBB2 input signals. If you are not using the safety function, connect the Safety Jumper Connector (provided as an accessory) to CN8.	-
A failure occurred in the SERVOPACK.	-	Replace the SERVOPACK.	-	

Continued from previous page.

Problem	Possible Cause	Confirmation	Correction	Reference
Servomotor Does Not Start	The polarity detection was not executed.	Check the setting of Pn080 = n.□□□X (Polarity Sensor Selection).	Correct the parameter setting.	-
		Check the /S-ON (Servo ON) signal.	<ul style="list-style-type: none"> If you are using an incremental linear encoder, input the /S-ON signal from the host controller. If you are using an absolute linear encoder, execute polarity detection. 	-
Servomotor Moves Instantaneously, and Then Stops	There is a mistake in the Servomotor wiring.	Check the wiring.	Wire the Servomotor correctly.	-
	There is a mistake in the wiring of the encoder or Serial Converter Unit.	Check the wiring.	Wire the Serial Converter Unit correctly.	-
	There is a mistake in the linear encoder wiring.	Check the wiring.	Wire the cable correctly.	-
	The setting of Pn282 (Linear Encoder Pitch) is not correct.	Check the setting of Pn282.	Correct the setting of Pn282.	-
	The count-up direction of the linear encoder does not match the forward direction of the Moving Coil in the motor.	Check the directions.	Change the setting of Pn080 = n.□□X□ (Motor Phase Selection). Place the linear encoder and motor in the same direction.	-
	Polarity detection was not performed correctly.	Check to see if electrical angle 2 (electrical angle from polarity origin) at any position is between $\pm 10^\circ$.	Correct the settings for the polarity detection-related parameters.	-
Servomotor Operation Is Unstable	There is a faulty connection in the Servomotor wiring.	The connector connections for the power line (U, V, and W phases) and the encoder or Serial Converter Unit may be unstable. Check the wiring.	Tighten any loose terminals or connectors and correct the wiring.	-
Servomotor Moves without a Reference Input	A failure occurred in the SERVOPACK.	-	Replace the SERVOPACK.	-
	The count-up direction of the linear encoder does not match the forward direction of the Moving Coil in the motor.	Check the directions.	Change the setting of Pn080 = n.□□X□ (Motor Phase Selection). Match the linear encoder direction and Servomotor direction.	-
	Polarity detection was not performed correctly.	Check to see if electrical angle 2 (electrical angle from polarity origin) at any position is between $\pm 10^\circ$.	Correct the settings for the polarity detection-related parameters.	-

Continued from previous page.

Problem	Possible Cause	Confirmation	Correction	Reference
Dynamic Brake Does Not Operate	The setting of Pn001 = n.□□□X (Servo OFF or Alarm Group 1 Stopping Method) is not suitable.	Check the setting of Pn001 = n.□□□X.	Set Pn001 = n.□□□X correctly.	-
	The dynamic brake resistor is disconnected.	Check the moment of inertia, motor speed, and dynamic brake frequency of use. If the moment of inertia, motor speed, or dynamic brake frequency of use is excessive, the dynamic brake resistance may be disconnected.	Replace the SERVO-PACK. To prevent disconnection, reduce the load.	-
	There was a failure in the dynamic brake drive circuit.	-	There is a defective component in the dynamic brake circuit. Replace the SERVO-PACK.	-
Abnormal Noise from Servomotor	The Servomotor vibrated considerably while performing the tuning-less function with the default settings.	Check the waveform of the motor speed.	Reduce the load so that the moment of inertia ratio or mass ratio is within the allowable value, or increase the load level or reduce the rigidity level in the tuning-less level settings.	-
	The machine mounting is not secure.	Check to see if there are any loose mounting screws.	Tighten the mounting screws.	-
		Check to see if there is misalignment in the coupling.	Align the coupling.	-
		Check to see if the coupling is balanced.	Balance the coupling.	-
	The bearings are defective.	Check for noise and vibration around the bearings.	Replace the Servomotor.	-
	There is a vibration source at the driven machine.	Check for any foreign matter, damage, or deformation in the machine's moving parts.	Consult with the machine manufacturer.	-
	Noise interference occurred because of incorrect I/O signal cable specifications.	Check the I/O signal cables to see if they satisfy specifications. Use shielded twisted-pair wire cables or screened twisted-pair cables with conductors of at least 0.12 mm ² .	Use cables that satisfy the specifications.	-
	Noise interference occurred because an I/O signal cable is too long.	Check the lengths of the I/O signal cables.	The I/O signal cables must be no longer than 3 m.	-
Noise interference occurred because of incorrect Encoder Cable specifications.	Make sure that the rotary or Linear Encoder Cable satisfies the specifications. Use a shielded twisted-pair wire cable or a screened twisted-pair cable with a conductors of at least 0.12 mm ² .	Use cables that satisfy the specifications.	-	

Continued from previous page.

Problem	Possible Cause	Confirmation	Correction	Reference
Abnormal Noise from Servomotor	Noise interference occurred because the Encoder Cable is too long.	Check the length of the Encoder Cable.	<ul style="list-style-type: none"> Rotary Servomotors: The Encoder Cable length must be 50 m max. Linear Servomotors: Make sure that the Serial Converter Unit cable is no longer than 20 m and that the Linear Encoder Cable and the Sensor Cable are no longer than 15 m each. 	-
	Noise interference occurred because the Encoder Cable is damaged.	Check the Encoder Cable to see if it is pinched or the sheath is damaged.	Replace the Encoder Cable and correct the cable installation environment.	-
	The Encoder Cable was subjected to excessive noise interference.	Check to see if the Encoder Cable is bundled with a high-current line or installed near a high-current line.	Correct the cable layout so that no surge is applied by high-current lines.	-
	There is variation in the FG potential because of the influence of machines on the Servomotor side, such as a welder.	Check to see if the machines are correctly grounded.	Properly ground the machines to separate them from the FG of the encoder.	-
	There is a SERVOPACK pulse counting error due to noise.	Check to see if there is noise interference on the signal line from the encoder.	Implement countermeasures against noise for the encoder wiring.	-
	The encoder was subjected to excessive vibration or shock.	Check to see if vibration from the machine occurred. Check the Servomotor installation (mounting surface precision, securing state, and alignment). Check the linear encoder installation (mounting surface precision and securing method).	Reduce machine vibration. Improve the mounting state of the Servomotor or linear encoder.	-
	A failure occurred in the encoder.	-	Replace the Servomotor.	-
	A failure occurred in the Serial Converter Unit.	-	Replace the Serial Converter Unit.	-
A failure occurred in the linear encoder.	-	Replace the linear encoder.	-	

Continued from previous page.

Problem	Possible Cause	Confirmation	Correction	Reference
Servomotor Vibrates at Frequency of Approx. 200 to 400 Hz.	The servo gains are not balanced.	Check to see if the servo gains have been correctly tuned.	Perform autotuning without a host reference.	-
	The setting of Pn100 (Speed Loop Gain) is too high.	Check the setting of Pn100. The default setting is Kv = 40.0 Hz.	Set Pn100 to an appropriate value.	-
	The setting of Pn102 (Position Loop Gain) is too high.	Check the setting of Pn102. The default setting is Kp = 40.0/s.	Set Pn102 to an appropriate value.	-
	The setting of Pn101 (Speed Loop Integral Time Constant) is not appropriate.	Check the setting of Pn101. The default setting is Ti = 20.0 ms.	Set Pn101 to an appropriate value.	-
	The setting of Pn103 (Moment of Inertia Ratio or Mass Ratio) is not appropriate.	Check the setting of Pn103.	Set Pn103 to an appropriate value.	-
Large Motor Speed Overshoot on Starting and Stopping	The servo gains are not balanced.	Check to see if the servo gains have been correctly tuned.	Perform autotuning without a host reference.	-
	The setting of Pn100 (Speed Loop Gain) is too high.	Check the setting of Pn100. The default setting is Kv = 40.0 Hz.	Set Pn100 to an appropriate value.	-
	The setting of Pn102 (Position Loop Gain) is too high.	Check the setting of Pn102. The default setting is Kp = 40.0/s.	Set Pn102 to an appropriate value.	-
	The setting of Pn101 (Speed Loop Integral Time Constant) is not appropriate.	Check the setting of Pn101. The default setting is Ti = 20.0 ms.	Set Pn101 to an appropriate value.	-
	The setting of Pn103 (Moment of Inertia Ratio or Mass Ratio) is not appropriate.	Check the setting of Pn103.	Set Pn103 to an appropriate value.	-
	The torque reference is saturated.	Check the waveform of the torque reference.	Use the mode switch.	-
	The force limits (Pn483 and Pn484) are set to the default values.	The default values of the force limits and Pn483 = 30% and Pn484 = 30%.	Set Pn483 and Pn484 to appropriate values.	-

Continued from previous page.

Problem	Possible Cause	Confirmation	Correction	Reference
Absolute Encoder Position Deviation Error (The position that was saved in the host controller when the power was turned OFF is different from the position when the power was next turned ON.)	Noise interference occurred because of incorrect Encoder Cable specifications.	Check the Encoder Cable to see if it satisfies specifications. Use a shielded twisted-pair wire cable or a screened twisted-pair cable with conductors of at least 0.12 mm ² .	Use cables that satisfy the specifications.	-
	Noise interference occurred because the Encoder Cable is too long.	Check the length of the Encoder Cable.	<ul style="list-style-type: none"> Rotary Servomotors: The Encoder Cable length must be 50 m max. Linear Servomotors: Make sure that the Serial Converter Unit cable is no longer than 20 m and that the Linear Encoder Cable and the Sensor Cable are no longer than 15 m each. 	-
	Noise interference occurred because the Encoder Cable is damaged.	Check the Encoder Cable to see if it is pinched or the sheath is damaged.	Replace the Encoder Cable and correct the cable installation environment.	-
	Noise interference occurred because the Encoder Cable is damaged.	Check to see if the Encoder Cable is bundled with a high-current line or installed near a high-current line.	Correct the cable layout so that no surge is applied by high-current lines.	-
	There is variation in the FG potential because of the influence of machines on the Servomotor side, such as a welder.	Check to see if the machines are correctly grounded.	Properly ground the machines to separate them from the FG of the encoder.	-
	There is a SERVOPACK pulse counting error due to noise.	Check to see if there is noise interference on the I/O signal line from the encoder or Serial Converter Unit.	Implement countermeasures against noise for the encoder or Serial Converter Unit wiring.	-
	The encoder was subjected to excessive vibration or shock.	Check to see if vibration from the machine occurred. Check the Servomotor installation (mounting surface precision, securing state, and alignment). Check the linear encoder installation (mounting surface precision and securing method).	Reduce machine vibration. Improve the mounting state of the Servomotor or linear encoder.	-
	A failure occurred in the encoder.	-	Replace the Servomotor or linear encoder.	-
A failure occurred in the SERVOPACK.	-	Replace the SERVOPACK.	-	

Continued from previous page.

Problem	Possible Cause	Confirmation	Correction	Reference
Overtravel Occurred	The P-OT/N-OT (Forward Drive Prohibit or Reverse Drive Prohibit) signal was input.	Check the external power supply (+24 V) voltage for the input signals.	Correct the external power supply (+24 V) voltage for the input signals.	-
		Check the operating condition of the overtravel limit switches.	Make sure that the overtravel limit switches operate correctly.	-
		Check the wiring of the overtravel limit switches.	Correct the wiring of the overtravel limit switches.	-
	The P-OT/N-OT (Forward Drive Prohibit or Reverse Drive Prohibit) signal malfunctioned.	Check for fluctuation in the external power supply (+24 V) voltage for the input signals.	Eliminate fluctuation from the external power supply (+24 V) voltage for the input signals.	-
		Check to see if the operation of the overtravel limit switches is unstable.	Stabilize the operating condition of the overtravel limit switches.	-
		Check the wiring of the overtravel limit switches (e.g., check for cable damage and loose screws).	Correct the wiring of the overtravel limit switches.	-
	The selection of the Servomotor stopping method is not correct.	Check the servo OFF stopping method set in Pn001 = n.□□□X or PnB1F.	Select a Servomotor stopping method other than coasting to a stop.	-
Improper Stop Position for Overtravel (OT) Signal	The limit switch position and dog length are not appropriate.	-	Install the limit switch at the appropriate position.	-
	The overtravel limit switch position is too close for the coasting distance.	-	Install the overtravel limit switch at the appropriate position.	-

Continued from previous page.

Problem	Possible Cause	Confirmation	Correction	Reference
Position Deviation (without Alarm)	Noise interference occurred because of incorrect Encoder Cable specifications.	Check the Encoder Cable to see if it satisfies specifications. Use a shielded twisted-pair wire cable or a screened twisted-pair cable with conductors of at least 0.12 mm ² .	Use cables that satisfy the specifications.	–
	Noise interference occurred because the Encoder Cable is too long.	Check the length of the Encoder Cable.	<ul style="list-style-type: none"> • Rotary Servomotors: The Encoder Cable length must be 50 m max. • Linear Servomotors: Make sure that the Serial Converter Unit cable is no longer than 20 m and that the Linear Encoder Cable and the Sensor Cable are no longer than 15 m each. 	–
	Noise interference occurred because the Encoder Cable is damaged.	Check the Encoder Cable to see if it is pinched or the sheath is damaged.	Replace the Encoder Cable and correct the cable installation environment.	–
	The Encoder Cable was subjected to excessive noise interference.	Check to see if the Encoder Cable is bundled with a high-current line or installed near a high-current line.	Correct the cable layout so that no surge is applied by high-current lines.	–
	There is variation in the FG potential because of the influence of machines on the Servomotor side, such as a welder.	Check to see if the machines are correctly grounded.	Properly ground the machines to separate them from the FG of the encoder.	–
	There is a SERVOPACK pulse counting error due to noise.	Check to see if there is noise interference on the I/O signal line from the encoder or Serial Converter Unit.	Implement countermeasures against noise for the encoder wiring or Serial Converter Unit wiring.	–

Continued from previous page.

Problem	Possible Cause	Confirmation	Correction	Reference
Position Deviation (without Alarm)	The encoder was subjected to excessive vibration or shock.	Check to see if vibration from the machine occurred. Check the Servomotor installation (mounting surface precision, securing state, and alignment). Check the linear encoder installation (mounting surface precision and securing method).	Reduce machine vibration. Improve the mounting state of the Servomotor or linear encoder.	-
	The coupling between the machine and Servomotor is not suitable.	Check to see if position offset occurs at the coupling between machine and Servomotor.	Correctly secure the coupling between the machine and Servomotor.	-
	Noise interference occurred because of incorrect I/O signal cable specifications.	Check the I/O signal cables to see if they satisfy specifications. Use a shielded twisted-pair wire cable or a screened twisted-pair cable with conductors of at least 0.12 mm ² .	Use cables that satisfy the specifications.	-
	Noise interference occurred because an I/O signal cable is too long.	Check the lengths of the I/O signal cables.	The I/O signal cables must be no longer than 3 m.	-
	An encoder fault occurred. (The pulse count does not change.)	-	Replace the Servomotor or linear encoder.	-
	A failure occurred in the SERVOPACK.	-	Replace the SERVOPACK.	-
Servomotor Overheated	The surrounding air temperature is too high.	Measure the surrounding air temperature around the Servomotor.	Reduce the surrounding air temperature to 40°C or less.	-
	The surface of the Servomotor is dirty.	Visually check the surface for dirt.	Clean dirt, dust, and oil from the surface.	-
	There is an overload on the Servomotor.	Check the load status with a monitor.	If the Servomotor is overloaded, reduce the load or replace the Servo Drive with a SERVOPACK and Servomotor with larger capacities.	-
	Polarity detection was not performed correctly.	Check to see if electrical angle 2 (electrical angle from polarity origin) at any position is between $\pm 10^\circ$.	Correct the settings for the polarity detection-related parameters.	-

Parameter Lists

9

This chapter provides information on the parameters.

9.1	Parameter Configurations	9-2
9.2	List of Parameters	9-3
9.2.1	Interpreting the Parameter Lists	9-3
9.2.2	List of Parameters	9-4

9.1 Parameter Configurations

Parameters are comprised of the types shown in the following table.

Type	Parameter No.	Parameter No.
Function Selection Parameters	Pn000 to Pn081	Select basic and application functions such as the type of control mode or the stop method when an alarm occurs.
Servo Gain and Other Parameters	Pn100 to Pn170	Set numerical values such as speed and position loop gains.
Position Control Parameters	Pn205 to Pn217	Set position control parameters such as average movement time.
Speed Control Parameters	Pn304 to Pn324	Set speed control parameters such as the speed feedback filter.
Torque Control Parameters	Pn401 to Pn460	Set torque control parameters such as the torque limit values.
Sequence Parameters	Pn502 to Pn561 Pn630 to Pn636 Pn64C	Set conditions for the sequence I/O signals.
Positioning Parameters	Pn637 to Pn640	Set parameters related to positioning.
Homing Parameters	Pn642 to Pn64A	Set parameters related to homing.
Others	Pn600 to Pn604	Set other parameters.
Fully-closed Loop Control Parameters	Pn20A, Pn22A, Pn281 Pn51B, Pn52A	Set parameters related to fully-closed loop control.
Linear Servomotor Parameters	Pn080 Pn181 to Pn182 Pn281 to Pn282 Pn383 to Pn385 Pn480 to Pn49F Pn581 to Pn587	Set parameters related to linear servomotors.

9.2 List of Parameters

9.2.1 Interpreting the Parameter Lists

The types of motors to which the parameter applies.

- All: The parameter is used for both Rotary Servomotors and Linear Servomotors.
- Rotary: The parameter is used for only Rotary Servomotors.
- Linear: The parameter is used for only Linear Servomotors.

Rotary Servomotor terms are used for parameters that are applicable to all Servomotors. If you are using a Linear Servomotor, you need to interpret the terms accordingly. Refer to the following section for details.

◆ Differences in Terms for Rotary Servomotors and Linear Servomotors on page x

Indicates when a change to the parameter will be effective.

Parameter No.	Size	Name	Setting Range	Setting Unit	Default Setting	Applicable Motors	When Enabled	Classification	Reference											
Pn000	2	Basic Function Selections 0	0000 to 10B1	-	0000	All	After restart	Setup	-											
			<p>If there are differences in the parameters for Rotary Servomotor and Linear Servomotor, information is provided for both.</p> <ul style="list-style-type: none"> • Top row: For Rotary Servomotors • Bottom row: For Linear Servomotors 																	
			<p>There are the following two classifications.</p> <ul style="list-style-type: none"> • Setup • Tuning <p>Refer to the following manual for details.</p> <p> Σ-7-Series Σ-7S SERVOPACK with Analog Voltage/Pulse Train References Product Manual (Manual No.: SIEP S800001 26)</p>																	
			<table border="1"> <thead> <tr> <th colspan="2">Rotation Direction Selection</th> <th rowspan="2">Reference</th> </tr> <tr> <th colspan="2">Movement Direction Selection</th> </tr> </thead> <tbody> <tr> <td rowspan="2">n.□□□X</td> <td>0</td> <td>Use CCW as the forward direction. Use the direction in which the linear encoder counts up as the forward direction.</td> <td rowspan="2">*1</td> </tr> <tr> <td>1</td> <td>Use CW as the forward direction. (Reverse Rotation Mode) Use the direction in which the linear encoder counts down as the forward direction. (Reverse Movement Mode)</td> </tr> </tbody> </table>							Rotation Direction Selection		Reference	Movement Direction Selection		n.□□□X	0	Use CCW as the forward direction. Use the direction in which the linear encoder counts up as the forward direction.	*1	1	Use CW as the forward direction. (Reverse Rotation Mode) Use the direction in which the linear encoder counts down as the forward direction. (Reverse Movement Mode)
	Rotation Direction Selection		Reference																	
	Movement Direction Selection																			
	n.□□□X	0	Use CCW as the forward direction. Use the direction in which the linear encoder counts up as the forward direction.	*1																
		1	Use CW as the forward direction. (Reverse Rotation Mode) Use the direction in which the linear encoder counts down as the forward direction. (Reverse Movement Mode)																	
			n.□□X□ Reserved parameter (Do not change.)																	
			n.□X□□ Reserved parameter (Do not change.)																	
		<table border="1"> <thead> <tr> <th colspan="2">Rotary/Linear Servomotor Startup Selection When Encoder Is Not Connected</th> <th>Reference</th> </tr> </thead> <tbody> <tr> <td rowspan="2">n.X□□□</td> <td>0</td> <td>When an encoder is not connected, start as SERVOPACK for Rotary Servomotor.</td> <td rowspan="2">*1</td> </tr> <tr> <td>1</td> <td>When an encoder is not connected, start as SERVOPACK for Linear Servomotor.</td> </tr> </tbody> </table>							Rotary/Linear Servomotor Startup Selection When Encoder Is Not Connected		Reference	n.X□□□	0	When an encoder is not connected, start as SERVOPACK for Rotary Servomotor.	*1	1	When an encoder is not connected, start as SERVOPACK for Linear Servomotor.			
Rotary/Linear Servomotor Startup Selection When Encoder Is Not Connected		Reference																		
n.X□□□	0	When an encoder is not connected, start as SERVOPACK for Rotary Servomotor.	*1																	
	1	When an encoder is not connected, start as SERVOPACK for Linear Servomotor.																		

9.2.2 List of Parameters

The following table lists the parameters.

Note: Do not change the following parameters from their default settings.

- Reserved parameters
- Parameters not given in this manual
- Parameters that are not valid for the Servomotor that you are using, as given in the parameter table

Parameter No.	Size	Name	Setting Range	Setting Unit	Default Setting	Applicable Motors	When Enabled	Classification	Reference	
Pn000	2	Basic Function Selections 0	0000 to 10B1	–	0010	All	After restart	Setup	–	
	n.□□□X	Rotation Direction Selection							Reference	*1
		Movement Direction Selection								
		0	Use CCW as the forward direction.							
			Use the direction in which the linear encoder counts up as the forward direction.							
	1	Use CW as the forward direction. (Reverse Rotation Mode)								
		Use the direction in which the linear encoder counts down as the forward direction. (Reverse Movement Mode)								
	n.□□X□	Control Method Selection							Reference	
		0	Speed control with analog references							
		1	Position control with pulse train references							
		2	Torque control with analog references							
		3	Internal set speed control with contact commands							
		4	Switching between internal set speed control with contact references and speed control with analog references							
5		Switching between internal set speed control with contact references and position control with pulse train references								
6		Switching between internal set speed control with contact references and torque control with analog references								
7		Switching between position control with pulse train references and speed control with analog references								
8		Switching between position control with pulse train references and torque control with analog references								
9		Switching between torque control with analog references and speed control with analog references								
A		Switching between speed control with analog references and speed control with zero clamping								
B	Switching between position control with pulse train references and position control with reference pulse inhibition									
n.□X□□	Reserved parameter (Do not change.)									
n.X□□□	Rotary/Linear Servomotor Startup Selection When Encoder Is Not Connected							Reference		
	0	When an encoder is not connected, start as SERVOPACK for Rotary Servomotor.								
	1	When an encoder is not connected, start as SERVOPACK for Linear Servomotor.								

Continued on next page.

Continued from previous page.

Parameter No.	Size	Name	Setting Range	Setting Unit	Default Setting	Applicable Motors	When Enabled	Classification	Reference		
Pn001	2	Application Function Selections 1	0000 to 1142	–	0000	All	After restart	Setup	–		
			Motor Stopping Method for Servo OFF and Group 1 Alarms							Reference	
	n.□□□X		0	Stop the motor by applying the dynamic brake.							*1
			1	Stop the motor by the applying dynamic brake and then release the dynamic brake.							
			2	Coast the motor to a stop without the dynamic brake.							
			Overtravel Stopping Method							Reference	
	n.□□X□		0	Apply the dynamic brake or coast the motor to a stop (use the stopping method set in Pn001 = n.□□□X).							*1
			1	Decelerate the motor to a stop using the torque set in Pn406 as the maximum torque and then servo-lock the motor.							
			2	Decelerate the motor to a stop using the torque set in Pn406 as the maximum torque and then let the motor coast.							
			3	Decelerate the motor to a stop using the deceleration time set in Pn30A and then servo-lock the motor.							
			4	Decelerate the motor to a stop using the deceleration time set in Pn30A and then let the motor coast.							
			Main Circuit Power Supply AC/DC Input Selection							Reference	
	n.□X□□		0	Input AC power as the main circuit power supply using the L1, L2, and L3 terminals (do not use shared converter).							*1
			1	Input DC power as the main circuit power supply using the B1/⊕ and ⊖ 2 terminals or the B1 and ⊖ 2 terminals (use an external converter or the shared converter).							
			Warning Code Output Selection							Reference	
	n.X□□□		0	Output only alarm codes on the /ALO1, /ALO2, and /ALO3 terminals.							*1
			1	Output both warning codes and alarm codes on the /ALO1, /ALO2, and /ALO3 terminals. However, while a warning code is being output, the ALM (Servo Alarm) output signal will remain ON (normal state).							

Continued on next page.

9.2 List of Parameters

9.2.2 List of Parameters

Continued from previous page.

Parameter No.	Size	Name	Setting Range	Setting Unit	Default Setting	Applicable Motors	When Enabled	Classification	Reference	
Pn002	2	Application Function Selections 2	0000 to 4213	–	0000	–	After restart	Setup	–	
			Speed/Position Control Option (T-REF Input Allocation)				Applicable Motors	Reference		
	n.□□□X		0	Do not use T-REF.			All	–		
			1	Use T-REF as an external torque limit input.				*1		
			2	Use T-REF as a torque feedback input.				*1		
			3	Use T-REF as an external torque limit input when /P-CL or /N-CL is ON.				*1		
			Torque Control Option (V-REF Input Allocation)				Applicable Motors	Reference		
	n.□□□□		0	Do not use V-REF.			All	*1		
			1	Use V-REF as an external speed limit input.						
			Encoder Usage				Applicable Motors	Reference		
	n.□X□□		0	Use the encoder according to encoder specifications.			All	*1		
			1	Use the encoder as an incremental encoder.						
			2	Use the encoder as a single-turn absolute encoder.			Rotary			
			External Encoder Usage				Applicable Motors	Reference		
	n.X□□□		0	Do not use an external encoder.			Rotary	*1		
			1	The external encoder moves in the forward direction for CCW motor rotation.						
			2	Reserved setting (Do not use.)						
			3	The external encoder moves in the reverse direction for CCW motor rotation.						
			4	Reserved setting (Do not use.)						

Continued on next page.

Continued from previous page.

Parameter No.	Size	Name	Setting Range	Setting Unit	Default Setting	Applicable Motors	When Enabled	Classification	Reference		
Pn006	2	Application Function Selections 6	0000 to 105F	–	0002	All	Immediately	Setup	*1		
	n.□□XX	Analog Monitor 1 Signal Selection									
		00	Motor speed (1 V/1,000 min ⁻¹) Motor speed (1 V/1,000 mm/s)								
		01	Speed reference (1 V/1,000 min ⁻¹) Speed reference (1 V/1,000 mm/s)								
		02	Torque reference (1 V/100% rated torque) Force reference (1 V/100% rated force)								
		03	Position deviation (0.05 V/reference unit)								
		04	Position amplifier deviation (after electronic gear) (0.05 V/encoder pulse unit) Position amplifier deviation (after electronic gear) (0.05 V/linear encoder pulse unit)								
		05	Position reference speed (1 V/1,000 min ⁻¹) Position reference speed (1 V/1,000 mm/s)								
		06	Reserved setting (Do not use.)								
		07	Load-motor position deviation (0.01 V/reference unit)								
		08	Positioning completion (positioning completed: 5 V, positioning not completed: 0 V)								
		09	Speed feedforward (1 V/1,000 min ⁻¹) Speed feedforward (1 V/1,000 mm/s)								
		0A	Torque feedforward (1 V/100% rated torque) Force feedforward (1 V/100% rated force)								
		0B	Active gain (1st gain: 1 V, 2nd gain: 2 V)								
		0C	Completion of position reference distribution (completed: 5 V, not completed: 0 V)								
		0D	External encoder speed (1 V/1,000 min ⁻¹ : value at the motor shaft)								
		0E	Reserved setting (Do not use.)								
		0F	Reserved setting (Do not use.)								
		10	Main circuit DC voltage								
		11 to 5F	Reserved settings (Do not use.)								
		n.□X□□	Reserved parameter (Do not change.)								
		n.X□□□	Reserved parameter (Do not change.)								

Continued on next page.

9.2 List of Parameters

9.2.2 List of Parameters

Continued from previous page.

Parameter No.	Size	Name	Setting Range	Setting Unit	Default Setting	Applicable Motors	When Enabled	Classification	Reference		
Pn007	2	Application Function Selections 7	0000 to 105F	–	0000	All	Immediately	Setup	*1		
	n.□□XX	Analog Monitor 2 Signal Selection									
		00	Motor speed (1 V/1,000 min ⁻¹)								
			Motor speed (1 V/1,000 mm/s)								
		01	Speed reference (1 V/1,000 min ⁻¹)								
			Speed reference (1 V/1,000 mm/s)								
		02	Torque reference (1 V/100% rated torque)								
			Force reference (1 V/100% rated force)								
		03	Position deviation (0.05 V/reference unit)								
		04	Position amplifier deviation (after electronic gear) (0.05 V/encoder pulse unit)								
			Position amplifier deviation (after electronic gear) (0.05 V/linear encoder pulse unit)								
		05	Position reference speed (1 V/1,000 min ⁻¹)								
			Position reference speed (1 V/1,000 mm/s)								
		06	Reserved setting (Do not use.)								
		07	Load-motor position deviation (0.01 V/reference unit)								
		08	Positioning completion (positioning completed: 5 V, positioning not completed: 0 V)								
		09	Speed feedforward (1 V/1,000 min ⁻¹)								
			Speed feedforward (1 V/1,000 mm/s)								
		0A	Torque feedforward (1 V/100% rated torque)								
			Force feedforward (1 V/100% rated force)								
		0B	Active gain (1st gain: 1 V, 2nd gain: 2 V)								
		0C	Completion of position reference distribution (completed: 5 V, not completed: 0 V)								
		0D	External encoder speed (1 V/1,000 min ⁻¹ : value at the motor shaft)								
		0E	Reserved setting (Do not use.)								
		0F	Reserved setting (Do not use.)								
		10	Main circuit DC voltage								
		11 to 5F	Reserved settings (Do not use.)								
		n.□X□□	Reserved parameter (Do not change.)								
n.X□□□		Reserved parameter (Do not change.)									

Continued on next page.

Continued from previous page.

Parameter No.	Size	Name	Setting Range	Setting Unit	Default Setting	Applicable Motors	When Enabled	Classification	Reference	
Pn008	2	Application Function Selections 8	0000 to 7121	–	0000	Rotary	After restart	Setup	–	
	n.□□□X	Low Battery Voltage Alarm/Warning Selection							Reference	
		0	Output alarm (A.830) for low battery voltage.							*1
		1	Output warning (A.930) for low battery voltage.							
	n.□□X□	Function Selection for Undervoltage							Reference	
		0	Do not detect undervoltage.							*1
		1	Detect undervoltage warning and limit torque at host controller.							
	2	Detect undervoltage warning and limit torque with Pn424 and Pn425 (i.e., only in SERVOPACK).								
	n.□X□□	Warning Detection Selection							Reference	
		0	Detect warnings.							*1
	1	Do not detect warnings except for A.971.								
n.X□□□	Reserved parameter (Do not change.)									
Pn009	2	Application Function Selections 9	0000 to 0121	–	0010	All	After restart	Tuning	–	
	n.□□□X	Reserved parameter (Do not change.)								
	n.□□X□	Current Control Mode Selection							Reference	
		0	Use current control mode 1.							*1
		1	<ul style="list-style-type: none"> • SERVOPACK Models SGD7S-R70A, -R90A, -1R6A, -2R8A, -3R8A, -5R5A, and -7R6A: Use current control mode 1. • SERVOPACK Models SGD7S-120A, -180A, -200A, -330A, -470A, -550A, -590A, and -780A: Use current control mode 2. 							
	2	Use current control mode 2.								
	n.□X□□	Speed Detection Method Selection							Reference	
		0	Use speed detection 1.							*1
		1	Use speed detection 2.							
	n.X□□□	Reserved parameter (Do not change.)								

Continued on next page.

9.2 List of Parameters

9.2.2 List of Parameters

Continued from previous page.

Parameter No.	Size	Name	Setting Range	Setting Unit	Default Setting	Applicable Motors	When Enabled	Classification	Reference	
Pn00A	2	Application Function Selections A	0000 to 0044	–	0001	All	After restart	Setup	–	
	n.□□□X	Motor Stopping Method for Group 2 Alarms								Reference
		0	Apply the dynamic brake or coast the motor to a stop (use the stopping method set in Pn001 = n.□□□X).							*1
		1	Decelerate the motor to a stop using the torque set in Pn406 as the maximum torque. Use the setting of Pn001 = n.□□□X for the status after stopping.							
		2	Decelerate the motor to a stop using the torque set in Pn406 as the maximum torque and then let the motor coast.							
		3	Decelerate the motor to a stop using the deceleration time set in Pn30A. Use the setting of Pn001 = n.□□□X for the status after stopping.							
	4	Decelerate the motor to a stop using the deceleration time set in Pn30A and then let the motor coast.								
	n.□□X□	Stopping Method for Forced Stops								Reference
		0	Apply the dynamic brake or coast the motor to a stop (use the stopping method set in Pn001 = n.□□□X).							*1
		1	Decelerate the motor to a stop using the torque set in Pn406 as the maximum torque. Use the setting of Pn001 = n.□□□X for the status after stopping.							
		2	Decelerate the motor to a stop using the torque set in Pn406 as the maximum torque and then let the motor coast.							
		3	Decelerate the motor to a stop using the deceleration time set in Pn30A. Use the setting of Pn001 = n.□□□X for the status after stopping.							
4	Decelerate the motor to a stop using the deceleration time set in Pn30A and then let the motor coast.									
n.□X□□	Reserved parameter (Do not change.)									
n.X□□□	Reserved parameter (Do not change.)									
Pn00B	2	Application Function Selections B	0000 to 1121	–	0000	All	After restart	Setup	–	
	n.□□□X	Operator Parameter Display Selection								Reference
		0	Display only setup parameters.							*1
	1	Display all parameters.								
	n.□□X□	Motor Stopping Method for Group 2 Alarms								Reference
		0	Stop the motor by setting the speed reference to 0.							*1
		1	Apply the dynamic brake or coast the motor to a stop (use the stopping method set in Pn001 = n.□□□X).							
	2	Set the stopping method with Pn00A = n.□□□X.								
	n.□X□□	Power Input Selection for Three-phase SERVOPACK								Reference
		0	Use a three-phase power supply input.							*1
1	Use a three-phase power supply input as a single-phase power supply input.									
n.X□□□	Reserved parameter (Do not change.)									

Continued on next page.

Continued from previous page.

Parameter No.	Size	Name	Setting Range	Setting Unit	Default Setting	Applicable Motors	When Enabled	Classification	Reference		
Pn00C	2	Application Function Selections C	0000 to 0131	–	0000	–	After restart	Setup	*1		
	n.□□□X	Function Selection for Test without a Motor							Applicable Motors		
		0	Disable tests without a motor.							All	
		1	Enable tests without a motor.								
	n.□□X□	Encoder Resolution for Tests without a Motor							Applicable Motors		
		0	Use 13 bits.							Rotary	
		1	Use 20 bits.								
		2	Use 22 bits.								
		3	Use 24 bits.								
	n.□X□□	Encoder Type Selection for Tests without a Motor							Applicable Motors		
0		Use an incremental encoder.							All		
	1	Use an absolute encoder.									
n.X□□□	Reserved parameter (Do not change.)										
Pn00D	2	Application Function Selections D	0000 to 1001	–	0000	All	After restart	Setup	*1		
	n.□□□X	Reserved parameter (Do not change.)									
	n.□□X□	Reserved parameter (Do not change.)									
	n.□X□□	Reserved parameter (Do not change.)									
	n.X□□□	Overtravel Warning Detection Selection									
		0	Do not detect overtravel warnings.								
	1	Detect overtravel warnings.									
Pn00F	2	Application Function Selections F	0000 to 2011	–	0000	All	After restart	Setup	–		
	n.□□□X	Preventative Maintenance Warning Selection							Reference		
		0	Do not detect preventative maintenance warnings.							*1	
		1	Detect preventative maintenance warnings.								
	n.□□X□	Reserved parameter (Do not change.)									
	n.□X□□	Reserved parameter (Do not change.)									
n.X□□□	Reserved parameter (Do not change.)										
Pn010	2	Axis Address Selection for UART/USB Communications	0000 to 007F	–	0001	All	After restart	Setup	–		
Pn021	2	Reserved parameter (Do not change.)	–	–	0000	All	–	–	–		

Continued on next page.

9.2 List of Parameters

9.2.2 List of Parameters

Continued from previous page.

Parameter No.	Size	Name	Setting Range	Setting Unit	Default Setting	Applicable Motors	When Enabled	Classification	Reference	
Pn040	2	Σ-V Compatible Function Switch	0000 to 2111	–	0000	–	After restart	Setup	–	
	n.□□□X		Reserved parameter (Do not change.)							
	n.□□□□		Encoder Resolution Compatibility Selection						Applicable Motors	
			0	Use the encoder resolution of the connected motor.					Rotary	
			1	Use a resolution of 20 bits when connected to an SGM7J, SGM7A, SGM7P, or SGM7G Servomotor.						
	n.□X□□		Reserved parameter (Do not change.)							
n.X□□□		Reserved parameter (Do not change.)								
Pn080	2	Application Function Selections 80	0000 to 1111	–	0000	Linear	After restart	Setup	–	
	n.□□□X		Polarity Sensor Selection						Reference	
			0	Use polarity sensor.					*1	
			1	Do not use polarity sensor.						
	n.□□□□		Motor Phase Sequence Selection						Reference	
			0	Set a phase-A lead as a phase sequence of U, V, and W.					*1	
		1	Set a phase-B lead as a phase sequence of U, V, and W.							
n.□X□□		Reserved parameter (Do not change.)								
n.X□□□		Calculation Method for Maximum Speed or Encoder Output Pulses						Reference		
		0	Calculate the encoder output pulse setting for a fixed maximum speed.					*1		
		1	Calculate the maximum speed for a fixed encoder output pulse setting.							
Pn081	2	Application Function Selections 81	0000 to 1111	–	0000	All	After restart	Setup	*1	
	n.□□□X		Phase-C Pulse Output Selection							
			0	Output phase-C pulses only in the forward direction.						
			1	Output phase-C pulses in both the forward and reverse directions.						
	n.□□X□		Reserved parameter (Do not change.)							
	n.□X□□		Reserved parameter (Do not change.)							
n.X□□□		Reserved parameter (Do not change.)								
Pn100	2	Speed Loop Gain	10 to 20,000	0.1 Hz	400	All	Immediately	Tuning	*1	
Pn101	2	Speed Loop Integral Time Constant	15 to 51,200	0.01 ms	2000	All	Immediately	Tuning	*1	
Pn102	2	Position Loop Gain	10 to 20,000	0.1/s	400	All	Immediately	Tuning	*1	
Pn103	2	Moment of Inertia Ratio	0 to 20,000	1%	100	All	Immediately	Tuning	*1	
Pn104	2	Second Speed Loop Gain	10 to 20,000	0.1 Hz	400	All	Immediately	Tuning	*1	
Pn105	2	Second Speed Loop Integral Time Constant	15 to 51,200	0.01 ms	2000	All	Immediately	Tuning	*1	
Pn106	2	Second Position Loop Gain	10 to 20,000	0.1/s	400	All	Immediately	Tuning	*1	

Continued on next page.

Continued from previous page.

Parameter No.	Size	Name	Setting Range	Setting Unit	Default Setting	Applicable Motors	When Enabled	Classification	Reference
Pn109	2	Feedforward	0 to 100	1%	0	All	Immediately	Tuning	*1
Pn10A	2	Feedforward Filter Time Constant	0 to 6,400	0.01 ms	0	All	Immediately	Tuning	*1
Pn10B	2	Gain Application Selections	0000 to 5334	-	0000	All	-	Setup	-
	n.□□□X	Mode Switching Selection						When Enabled	Reference
		0	Use the internal torque reference as the condition (level setting: Pn10C).					Immediately	*1
		1	Use the speed reference as the condition (level setting: Pn10D).						
			Use the speed reference as the condition (level setting: Pn181).						
		2	Use the acceleration reference as the condition (level setting: Pn10E).						
			Use the acceleration reference as the condition (level setting: Pn182).						
	3	Use the position deviation as the condition (level setting: Pn10F).							
	4	Do not use mode switching.							
	n.□□X□	Speed Loop Control Method						When Enabled	Reference
0		PI control					After restart	*1	
1		I-P control							
2, 3	Reserved settings (Do not use.)								
n.□X□□	Reserved parameter (Do not change.)								
n.X□□□	Reserved parameter (Do not change.)								
Pn10C	2	Mode Switching Level for Torque Reference	0 to 800	1%	200	All	Immediately	Tuning	*1
Pn10D	2	Mode Switching Level for Speed Reference	0 to 10,000	1 min ⁻¹	0	Rotary	Immediately	Tuning	*1
Pn10E	2	Mode Switching Level for Acceleration	0 to 30,000	1 min ⁻¹ /s	0	Rotary	Immediately	Tuning	*1
Pn10F	2	Mode Switching Level for Position Deviation	0 to 10,000	1 reference unit	0	All	Immediately	Tuning	*1
Pn11F	2	Position Integral Time Constant	0 to 50,000	0.1 ms	0	All	Immediately	Tuning	*1
Pn121	2	Friction Compensation Gain	10 to 1,000	1%	100	All	Immediately	Tuning	*1
Pn122	2	Second Friction Compensation Gain	10 to 1,000	1%	100	All	Immediately	Tuning	*1
Pn123	2	Friction Compensation Coefficient	0 to 100	1%	0	All	Immediately	Tuning	*1
Pn124	2	Friction Compensation Frequency Correction	-10,000 to 10,000	0.1 Hz	0	All	Immediately	Tuning	*1
Pn125	2	Friction Compensation Gain Correction	1 to 1,000	1%	100	All	Immediately	Tuning	*1
Pn131	2	Gain Switching Time 1	0 to 65,535	1 ms	0	All	Immediately	Tuning	*1
Pn132	2	Gain Switching Time 2	0 to 65,535	1 ms	0	All	Immediately	Tuning	*1
Pn135	2	Gain Switching Waiting Time 1	0 to 65,535	1 ms	0	All	Immediately	Tuning	*1
Pn136	2	Gain Switching Waiting Time 2	0 to 65,535	1 ms	0	All	Immediately	Tuning	*1

Continued on next page.

9.2 List of Parameters

9.2.2 List of Parameters

Continued from previous page.

Parameter No.	Size	Name	Setting Range	Setting Unit	Default Setting	Applicable Motors	When Enabled	Classification	Reference	
Pn139	2	Automatic Gain Switching Selections 1	0000 to 0052	–	0000	All	Immediately	Tuning	*1	
	n.□□□X	Gain Switching Selection		0	Use manual gain switching. The gain is switched manually with the /G-SEL (Gain Selection) signal.					
				1	Reserved setting (Do not use.)					
				2	Use automatic gain switching pattern 1. The gain is switched automatically from the first gain to the second gain when switching condition A is satisfied. The gain is switched automatically from the second gain to the first gain when switching condition A is not satisfied.					
	n.□□X□	Gain Switching Condition A		0	/COIN (Positioning Completion Output) signal turns ON.					
				1	/COIN (Positioning Completion Output) signal turns OFF.					
				2	/NEAR (Near Output) signal turns ON.					
				3	/NEAR (Near Output) signal turns OFF.					
				4	Position reference filter output is 0 and reference pulse input is OFF.					
				5	Position reference pulse input is ON.					
n.□X□□	Reserved parameter (Do not change.)									
n.X□□□	Reserved parameter (Do not change.)									
Pn13D	2	Current Gain Level	100 to 2,000	1%	2000	All	Immediately	Tuning	*1	
Pn140	2	Model Following Control-Related Selections	0000 to 1121	–	0100	All	Immediately	Tuning	–	
	n.□□□X	Model Following Control Selection		0	Do not use model following control.					*1
				1	Use model following control.					
	n.□□X□	Vibration Suppression Selection		0	Do not perform vibration suppression.					*1
				1	Perform vibration suppression for a specific frequency.					
				2	Perform vibration suppression for two specific frequencies.					
	n.□X□□	Vibration Suppression Adjustment Selection		0	Do not adjust vibration suppression automatically during execution of autotuning without a host reference, autotuning with a host reference, and custom tuning.					*1
				1	Adjust vibration suppression automatically during execution of autotuning without a host reference, autotuning with a host reference, and custom tuning.					
	n.X□□□	Speed Feedforward (VFF)/Torque Feedforward (TFF) Selection		0	Do not use model following control and speed/torque feedforward together.					*1
				1	Use model following control and speed/torque feedforward together.					
Pn141	2	Model Following Control Gain	10 to 20,000	0.1/s	500	All	Immediately	Tuning	*1	
Pn142	2	Model Following Control Gain Correction	500 to 2,000	0.1%	1000	All	Immediately	Tuning	*1	
Pn143	2	Model Following Control Bias in the Forward Direction	0 to 10,000	0.1%	1000	All	Immediately	Tuning	*1	

Continued on next page.

Continued from previous page.

Parameter No.	Size	Name	Setting Range	Setting Unit	Default Setting	Applicable Motors	When Enabled	Classification	Reference	
Pn144	2	Model Following Control Bias in the Reverse Direction	0 to 10,000	0.1%	1000	All	Immediately	Tuning	*1	
Pn145	2	Vibration Suppression 1 Frequency A	10 to 2,500	0.1 Hz	500	All	Immediately	Tuning	*1	
Pn146	2	Vibration Suppression 1 Frequency B	10 to 2,500	0.1 Hz	700	All	Immediately	Tuning	*1	
Pn147	2	Model Following Control Speed Feedforward Compensation	0 to 10,000	0.1%	1000	All	Immediately	Tuning	*1	
Pn148	2	Second Model Following Control Gain	10 to 20,000	0.1/s	500	All	Immediately	Tuning	*1	
Pn149	2	Second Model Following Control Gain Correction	500 to 2,000	0.1%	1000	All	Immediately	Tuning	*1	
Pn14A	2	Vibration Suppression 2 Frequency	10 to 2,000	0.1 Hz	800	All	Immediately	Tuning	*1	
Pn14B	2	Vibration Suppression 2 Correction	10 to 1,000	1%	100	All	Immediately	Tuning	*1	
Pn14F	2	Control-Related Selections	0000 to 0021	-	0021	All	After restart	Tuning	-	
	n.□□□X		Model Following Control Type Selection						Reference	
			0	Use model following control type 1.					*1	
			1	Use model following control type 2.						
	n.□□X□		Tuning-less Type Selection						Reference	
			0	Use tuning-less type 1.					*1	
		1	Use tuning-less type 2.							
		2	Use tuning-less type 3.							
n.□X□□		Reserved parameter (Do not change.)								
n.X□□□		Reserved parameter (Do not change.)								
Pn160	2	Anti-Resonance Control-Related Selections	0000 to 0011	-	0010	All	Immediately	Tuning	-	
	n.□□□X		Anti-Resonance Control Selection						Reference	
			0	Do not use anti-resonance control.					*1	
			1	Use anti-resonance control.						
	n.□□X□		Anti-Resonance Control Adjustment Selection						Reference	
			0	Do not adjust anti-resonance control automatically during execution of autotuning without a host reference, autotuning with a host reference, and custom tuning.					*1	
		1	Adjust anti-resonance control automatically during execution of autotuning without a host reference, autotuning with a host reference, and custom tuning.							
n.□X□□		Reserved parameter (Do not change.)								
n.X□□□		Reserved parameter (Do not change.)								
Pn161	2	Anti-Resonance Frequency	10 to 20,000	0.1 Hz	1000	All	Immediately	Tuning	*1	
Pn162	2	Anti-Resonance Gain Correction	1 to 1,000	1%	100	All	Immediately	Tuning	*1	
Pn163	2	Anti-Resonance Damping Gain	0 to 300	1%	0	All	Immediately	Tuning	*1	

Continued on next page.

9.2 List of Parameters

9.2.2 List of Parameters

Continued from previous page.

Parameter No.	Size	Name	Setting Range	Setting Unit	Default Setting	Applicable Motors	When Enabled	Classification	Reference
Pn164	2	Anti-Resonance Filter Time Constant 1 Correction	-1,000 to 1,000	0.01 ms	0	All	Immediately	Tuning	*1
Pn165	2	Anti-Resonance Filter Time Constant 2 Correction	-1,000 to 1,000	0.01 ms	0	All	Immediately	Tuning	*1
Pn166	2	Anti-Resonance Damping Gain 2	0 to 1,000	1%	0	All	Immediately	Tuning	*1
Pn170	2	Tuning-less Function-Related Selections	0000 to 2711	-	1401	All	-	Setup	*1
		n.□□□X		Tuning-less Selection				When Enabled	
			0	Disable tuning-less function.				After restart	
			1	Enable tuning-less function.					
		n.□□X□		Speed Control Method				When Enabled	
		0	Use for speed control.				After restart		
		1	Use for speed control and use host controller for position control.						
	n.□X□□		Rigidity Level				When Enabled		
		0 to 7	Set the rigidity level.				Immediately		
	n.X□□□		Tuning-less Load Level				When Enabled		
		0 to 2	Set the load level for the tuning-less function.				Immediately		
Pn181	2	Mode Switching Level for Speed Reference	0 to 10,000	1 mm/s	0	Linear	Immediately	Tuning	*1
Pn182	2	Mode Switching Level for Acceleration	0 to 30,000	1 mm/s ²	0	Linear	Immediately	Tuning	*1

Continued on next page.

Continued from previous page.

Parameter No.	Size	Name	Setting Range	Setting Unit	Default Setting	Applicable Motors	When Enabled	Classification	Reference		
Pn200	2	Position Control Reference For Selections	0000 to 2236	–	0000	All	After restart	Setup	–		
			Reference Pulse Form							Reference	
			0	Sign and pulse train, positive logic.							*1
			1	CW and CCW pulse trains, positive logic							
			2	Two-phase pulse trains with 90° phase differential (phase A and phase B) ×1, positive logic							
			3	Two-phase pulse trains with 90° phase differential (phase A and phase B) ×2, positive logic							
			4	Two-phase pulse trains with 90° phase differential (phase A and phase B) ×4, positive logic							
			5	Sign and pulse train, negative logic.							
			6	CW and CCW pulse trains, negative logic							
			Clear Signal Form							Reference	
			0	Clear position deviation when the signal is at high level.							*1
			1	Clear position deviation on the rising edge of the signal.							
			2	Clear position deviation when the signal is at low level.							
			3	Clear position deviation on the falling edge of the signal.							
			Clear Operation							Reference	
			0	Clear position deviation at a base block (at servo OFF or when alarm occurs).							*1
			1	Do not clear position error (cleared only with CLR (Clear Position Deviation) signal).							
			2	Clear position deviation when an alarm occurs.							
			Filter Selection							Reference	
			0	Use reference input filter 1 for a line-driver signal. (1 Mpps max.)							*1
			1	Use the reference input filter for an open-collector signal. (200 kpps max.)							
		2	Use reference input filter 2 for a line-driver signal. (1 to 4 Mpps)								
Pn205	2	Multiturn Limit	0 to 65,535	1 rev	65535	Rotary	After restart	Setup	*1		
Pn207	2	Position Control Function Selections	0000 to 2210	–	2000	All	After restart	Setup	–		
			n.□□□X Reserved parameter (Do not change.)								
			Position Control Option							Reference	
			0	Do not use V-REF.							*1
			1	Use V-REF as a speed feedback input.							
			n.□X□□ Reserved parameter (Do not change.)								
			/COIN (Positioning Completion Output) Signal Output Timing							Reference	
			0	Output when the absolute value of the position deviation is the same or less than the setting of Pn522 (Positioning Completed Width).							*1
			1	Output when the absolute value of the position error is the same or less than the setting of Pn522 (Positioning Completed Width) and the reference after the position reference filter is 0.							
			2	Output when the absolute value of the position error is the same or less than the setting of Pn522 (Positioning Completed Width) and the reference input is 0.							

Continued on next page.

9.2 List of Parameters

9.2.2 List of Parameters

Continued from previous page.

Parameter No.	Size	Name	Setting Range	Setting Unit	Default Setting	Applicable Motors	When Enabled	Classification	Reference	
Pn20A	4	Number of External Encoder Scale Pitches	4 to 1,048,576	1 scale pitch/revolution	32768	Rotary	After restart	Setup	*1	
Pn20E	4	Electronic Gear Ratio (Numerator)	1 to 1,073,741,824	1	64	All	After restart	Setup	*1	
Pn210	4	Electronic Gear Ratio (Denominator)	1 to 1,073,741,824	1	1	All	After restart	Setup	*1	
Pn212	4	Number of Encoder Output Pulses	16 to 1,073,741,824	1 P/Rev	2048	Rotary	After restart	Setup	*1	
Pn216	2	Position Reference Acceleration/Deceleration Time Constant	0 to 65,535	0.1 ms	0	All	Immediately after the motor stops	Setup	*1	
Pn217	2	Average Position Reference Movement Time	0 to 10,000	0.1 ms	0	All	Immediately after the motor stops	Setup	*1	
Pn218	2	Reference Pulse Input Multiplier	1 to 100	× 1	1	All	Immediately	Setup	*1	
Pn22A	2	Fully-closed Control Selections	0000 to 1003	–	0000	Rotary	After restart	Setup	*1	
	n.□□□X		Reserved parameter (Do not change.)							
	n.□□X□		Reserved parameter (Do not change.)							
	n.□X□□		Reserved parameter (Do not change.)							
	n.X□□□		Fully-closed Control Speed Feedback Selection							
		0	Use motor encoder speed.							
		1	Use external encoder speed.							
Pn281	2	Encoder Output Resolution	1 to 4,096	1 edge/pitch	20	All	After restart	Setup	*1	
Pn282	4	Linear Encoder Scale Pitch	0 to 6,553,600	0.01 μm	0	Linear	After restart	Setup	*1	
Pn300	2	Speed Reference Input Gain	150 to 3,000	0.01 V/ Rated motor speed	600	All	Immediately	Setup	*1	
Pn301	2	Internal Set Speed 1	0 to 10,000	Rotary: 1 min ⁻¹ Direct Drive: 0.1 min ⁻¹	100	Rotary	Immediately	Setup	*1	
Pn302	2	Internal Set Speed 2	0 to 10,000	Rotary: 1 min ⁻¹ Direct Drive: 0.1 min ⁻¹	200	Rotary	Immediately	Setup	*1	
Pn303	2	Internal Set Speed 3	0 to 10,000	Rotary: 1 min ⁻¹ Direct Drive: 0.1 min ⁻¹	300	Rotary	Immediately	Setup	*1	
Pn304	2	Jog Operation Speed	0 to 10,000	Rotary: 1 min ⁻¹ Direct Drive: 0.1 min ⁻¹	500	Rotary	Immediately	Setup	*1	
Pn305	2	Soft Start Acceleration Time	0 to 10,000	1 ms	0	All	Immediately	Setup	*1	

Continued on next page.

Continued from previous page.

Parameter No.	Size	Name	Setting Range	Setting Unit	Default Setting	Applicable Motors	When Enabled	Classification	Reference								
Pn306	2	Soft Start Deceleration Time	0 to 10,000	1 ms	0	All	Immediately	Setup	*1								
Pn307	2	Speed Reference Filter Time Constant	0 to 65,535	0.01 ms	40	All	Immediately	Setup	*1								
Pn308	2	Speed Feedback Filter Time Constant	0 to 65,535	0.01 ms	0	All	Immediately	Setup	*1								
Pn30A	2	Deceleration Time for Servo OFF and Forced Stops	0 to 10,000	1 ms	0	All	Immediately	Setup	*1								
Pn30C	2	Speed Feedforward Average Movement Time	0 to 5,100	0.1 ms	0	All	Immediately	Setup	*1								
Pn310	2	Vibration Detection Selections	0000 to 0002	–	0000	All	Immediately	Setup	*1								
		<table border="1"> <thead> <tr> <th colspan="2">Vibration Detection Selection</th> </tr> </thead> <tbody> <tr> <td>0</td> <td>Do not detect vibration.</td> </tr> <tr> <td>1</td> <td>Output a warning (A.911) if vibration is detected.</td> </tr> <tr> <td>2</td> <td>Output an alarm (A.520) if vibration is detected.</td> </tr> </tbody> </table>								Vibration Detection Selection		0	Do not detect vibration.	1	Output a warning (A.911) if vibration is detected.	2	Output an alarm (A.520) if vibration is detected.
	Vibration Detection Selection																
	0	Do not detect vibration.															
	1	Output a warning (A.911) if vibration is detected.															
	2	Output an alarm (A.520) if vibration is detected.															
	n.□□□X	Reserved parameter (Do not change.)															
	n.□X□□	Reserved parameter (Do not change.)															
	n.X□□□	Reserved parameter (Do not change.)															
Pn311	2	Vibration Detection Sensitivity	50 to 500	1%	100	All	Immediately	Tuning	*1								
Pn312	2	Vibration Detection Level	0 to 5,000	1 min ⁻¹	50	Rotary	Immediately	Tuning	*1								
Pn316	2	Maximum Motor Speed	0 to 65,535	1 min ⁻¹	10000	Rotary	After restart	Setup	*1								
Pn324	2	Moment of Inertia Calculation Starting Level	0 to 20,000	1%	300	All	Immediately	Setup	*1								
Pn380	2	Internal Set Speed 1	0 to 10,000	1 mm/s	10	Linear	Immediately	Setup	*1								
Pn381	2	Internal Set Speed 2	0 to 10,000	1 mm/s	20	Linear	Immediately	Setup	*1								
Pn382	2	Internal Set Speed 3	0 to 10,000	1 mm/s	30	Linear	Immediately	Setup	*1								
Pn383	2	Jog Operation Speed	0 to 10,000	1 mm/s	50	Linear	Immediately	Setup	*1								
Pn384	2	Vibration Detection Level	0 to 5,000	1 mm/s	10	Linear	Immediately	Tuning	*1								
Pn385	2	Maximum Motor Speed	1 to 100	100 mm/s	50	Linear	After restart	Setup	*1								
Pn400	2	Torque Reference Input Gain	10 to 100	0.1 V/rated torque	30	All	Immediately	Setup	*1								
Pn401	2	First Stage First Torque Reference Filter Time Constant	0 to 65,535	0.01 ms	100	All	Immediately	Tuning	*1								
Pn402	2	Forward Torque Limit	0 to 800	1%*2	800	Rotary	Immediately	Setup	*1								
Pn403	2	Reverse Torque Limit	0 to 800	1%*2	800	Rotary	Immediately	Setup	*1								
Pn404	2	Forward External Torque Limit	0 to 800	1%*2	100	All	Immediately	Setup	*1								
Pn405	2	Reverse External Torque Limit	0 to 800	1%*2	100	All	Immediately	Setup	*1								
Pn406	2	Emergency Stop Torque	0 to 800	1%*2	800	All	Immediately	Setup	*1								

Continued on next page.

9.2 List of Parameters

9.2.2 List of Parameters

Continued from previous page.

Parameter No.	Size	Name	Setting Range	Setting Unit	Default Setting	Applicable Motors	When Enabled	Classification	Reference	
Pn407	2	Speed Limit during Torque Control	0 to 10,000	1 min ⁻¹	10000	Rotary	Immediately	Setup	*1	
Pn408	2	Torque-Related Function Selections	0000 to 1111	–	0000	All	–	Setup	–	
	n.□□□X		Notch Filter Selection 1				When Enabled	Reference		
			0	Disable first stage notch filter.			Immediately	*1		
			1	Enable first stage notch filter.						
	n.□□X□		Speed Limit Selection				When Enabled	Reference		
			0	Use the smaller of the maximum motor speed and the setting of Pn407 as the speed limit.			After restart	*1		
				Use the smaller of the maximum motor speed and the setting of Pn480 as the speed limit.						
			1	Use the smaller of the overspeed alarm detection speed and the setting of Pn407 as the speed limit.						
				Use the smaller of the overspeed alarm detection speed and the setting of Pn480 as the speed limit.						
	n.□X□□		Notch Filter Selection 2				When Enabled	Reference		
		0	Disable second stage notch filter.			Immediately	*1			
		1	Enable second stage notch filter.							
n.X□□□		Friction Compensation Function Selection				When Enabled	Reference			
		0	Disable friction compensation.			Immediately	*1			
		1	Enable friction compensation.							
Pn409	2	First Stage Notch Filter Frequency	50 to 5,000	1 Hz	5000	All	Immediately	Tuning	*1	
Pn40A	2	First Stage Notch Filter Q Value	50 to 1,000	0.01	70	All	Immediately	Tuning	*1	
Pn40B	2	First Stage Notch Filter Depth	0 to 1,000	0.001	0	All	Immediately	Tuning	*1	
Pn40C	2	Second Stage Notch Filter Frequency	50 to 5,000	1 Hz	5000	All	Immediately	Tuning	*1	
Pn40D	2	Second Stage Notch Filter Q Value	50 to 1,000	0.01	70	All	Immediately	Tuning	*1	
Pn40E	2	Second Stage Notch Filter Depth	0 to 1,000	0.001	0	All	Immediately	Tuning	*1	
Pn40F	2	Second Stage Second Torque Reference Filter Frequency	100 to 5,000	1 Hz	5000	All	Immediately	Tuning	*1	
Pn410	2	Second Stage Second Notch Filter Q Value	50 to 100	0.01	50	All	Immediately	Tuning	*1	
Pn412	2	First Stage Second Torque Reference Filter Time Constant	0 to 65,535	0.01 ms	100	All	Immediately	Tuning	*1	
Pn415	2	T-REF Filter Time Constant	0 to 65,535	0.01 ms	0	All	Immediately	Setup	*1	

Continued on next page.

Continued from previous page.

Parameter No.	Size	Name	Setting Range	Setting Unit	Default Setting	Applicable Motors	When Enabled	Classification	Reference
Pn416	2	Torque-Related Function Selections 2	0000 to 1111	–	0000	All	Immediately	Setup	*1
	n.□□□X	Notch Filter Selection 3							
		0	Disable third stage notch filter.						
	1	Enable third stage notch filter.							
	n.□□X□	Notch Filter Selection 4							
		0	Disable fourth stage notch filter.						
	1	Enable fourth stage notch filter.							
	n.□X□□	Notch Filter Selection 5							
		0	Disable fifth stage notch filter.						
	1	Enable fifth stage notch filter.							
n.X□□□	Reserved parameter (Do not change.)								
Pn417	2	Third Stage Notch Filter Frequency	50 to 5,000	1 Hz	5000	All	Immediately	Tuning	*1
Pn418	2	Third Stage Notch Filter Q Value	50 to 1,000	0.01	70	All	Immediately	Tuning	*1
Pn419	2	Third Stage Notch Filter Depth	0 to 1,000	0.001	0	All	Immediately	Tuning	*1
Pn41A	2	Fourth Stage Notch Filter Frequency	50 to 5,000	1 Hz	5000	All	Immediately	Tuning	*1
Pn41B	2	Fourth Stage Notch Filter Q Value	50 to 1,000	0.01	70	All	Immediately	Tuning	*1
Pn41C	2	Fourth Stage Notch Filter Depth	0 to 1,000	0.001	0	All	Immediately	Tuning	*1
Pn41D	2	Fifth Stage Notch Filter Frequency	50 to 5,000	1 Hz	5000	All	Immediately	Tuning	*1
Pn41E	2	Fifth Stage Notch Filter Q Value	50 to 1,000	0.01	70	All	Immediately	Tuning	*1
Pn41F	2	Fifth Stage Notch Filter Depth	0 to 1,000	0.001	0	All	Immediately	Tuning	*1
Pn423	2	Speed Ripple Compensation Selections	0000 to 1111	–	0000	Rotary	–	Setup	*1
	n.□□□X	Speed Ripple Compensation Function Selection							
		0	Disable speed ripple compensation.					Immediately	
	1	Enable speed ripple compensation.							
	n.□□X□	Speed Ripple Compensation Information Disagreement Warning Detection Selection							
		0	Detect A.942 alarms.					After restart	
	1	Do not detect A.942 alarms.							
	n.□X□□	Speed Ripple Compensation Enable Condition Selection							
		0	Speed reference					After restart	
	1	Motor speed							
n.X□□□	Reserved parameter (Do not change.)								
Pn424	2	Torque Limit at Main Circuit Voltage Drop	0 to 100	1%*1	50	All	Immediately	Setup	*1

Continued on next page.

9.2 List of Parameters

9.2.2 List of Parameters

Continued from previous page.

Parameter No.	Size	Name	Setting Range	Setting Unit	Default Setting	Applicable Motors	When Enabled	Classification	Reference
Pn425	2	Release Time for Torque Limit at Main Circuit Voltage Drop	0 to 1,000	1 ms	100	All	Immediately	Setup	*1
Pn426	2	Torque Feedforward Average Movement Time	0 to 5,100	0.1 ms	0	All	Immediately	Setup	*1
Pn427	2	Speed Ripple Compensation Enable Speed	0 to 10,000	1 min ⁻¹	0	Rotary	Immediately	Tuning	*1
Pn456	2	Sweep Torque Reference Amplitude	1 to 800	1%	15	All	Immediately	Tuning	*1
Pn460	2	Notch Filter Adjustment Selections 1	0000 to 0101	–	0101	All	Immediately	Tuning	*1
	n.□□□X		Notch Filter Adjustment Selection 1						
		0	Do not adjust the first stage notch filter automatically during execution of autotuning without a host reference, autotuning with a host reference, and custom tuning.						
		1	Adjust the first stage notch filter automatically during execution of autotuning without a host reference, autotuning with a host reference, and custom tuning.						
	n.□□X□		Reserved parameter (Do not change.)						
	n.□X□□		Notch Filter Adjustment Selection 2						
	0	Do not adjust the second stage notch filter automatically during execution of autotuning without a host reference, autotuning with a host reference, and custom tuning.							
	1	Adjust the second stage notch filter automatically during execution of autotuning without a host reference, autotuning with a host reference, and custom tuning.							
n.X□□□		Reserved parameter (Do not change.)							
Pn480	2	Speed Limit during Force Control	0 to 10,000	1 mm/s	10000	Linear	Immediately	Setup	*1
Pn481	2	Polarity Detection Speed Loop Gain	10 to 20,000	0.1 Hz	400	Linear	Immediately	Tuning	–
Pn482	2	Polarity Detection Speed Loop Integral Time Constant	15 to 51,200	0.01 ms	3000	Linear	Immediately	Tuning	–
Pn483	2	Forward Force Limit	0 to 800	1%*2	30	Linear	Immediately	Setup	*1
Pn484	2	Reverse Force Limit	0 to 800	1%*2	30	Linear	Immediately	Setup	*1
Pn485	2	Polarity Detection Reference Speed	0 to 100	1 mm/s	20	Linear	Immediately	Tuning	–
Pn486	2	Polarity Detection Reference Acceleration/Deceleration Time	0 to 100	1 ms	25	Linear	Immediately	Tuning	–
Pn487	2	Polarity Detection Constant Speed Time	0 to 300	1 ms	0	Linear	Immediately	Tuning	–
Pn488	2	Polarity Detection Reference Waiting Time	50 to 500	1 ms	100	Linear	Immediately	Tuning	–
Pn48E	2	Polarity Detection Range	1 to 65,535	1 mm	10	Linear	Immediately	Tuning	–
Pn490	2	Polarity Detection Load Level	0 to 20,000	1%	100	Linear	Immediately	Tuning	–
Pn495	2	Polarity Detection Confirmation Force Reference	0 to 200	1%	100	Linear	Immediately	Tuning	–
Pn498	2	Polarity Detection Allowable Error Range	0 to 30	1 deg	10	Linear	Immediately	Tuning	–
Pn49F	2	Speed Ripple Compensation Enable Speed	0 to 10,000	1 mm/s	0	Linear	Immediately	Tuning	*1
Pn501	2	Zero Clamping Level	0 to 10,000	1 min ⁻¹	10	Rotary	Immediately	Setup	*1

Continued on next page.

Continued from previous page.

Parameter No.	Size	Name	Setting Range	Setting Unit	Default Setting	Applicable Motors	When Enabled	Classification	Reference
Pn502	2	Rotation Detection Level	1 to 10,000	1 min ⁻¹	20	Rotary	Immediately	Setup	*1
Pn503	2	Speed Coincidence Detection Signal Output Width	0 to 100	1 min ⁻¹	10	Rotary	Immediately	Setup	*1
Pn506	2	Brake Reference-Servo OFF Delay Time	0 to 50	10 ms	0	All	Immediately	Setup	*1
Pn507	2	Brake Reference Output Speed Level	0 to 10,000	1 min ⁻¹	100	Rotary	Immediately	Setup	*1
Pn508	2	Servo OFF-Brake Command Waiting Time	10 to 100	10 ms	50	All	Immediately	Setup	*1
Pn509	2	Momentary Power Interruption Hold Time	20 to 50,000	1 ms	20	All	Immediately	Setup	*1

Continued on next page.

9.2 List of Parameters

9.2.2 List of Parameters

Continued from previous page.

Parameter No.	Size	Name	Setting Range	Setting Unit	Default Setting	Applicable Motors	When Enabled	Classification	Reference	
Pn50A	2	Input Signal Selections 1	0000 to FFF2	-	8801	All	After restart	Setup	-	
	n.□□□X		Input Signal Allocation Mode							Reference
		0	Use the sequence input signal terminals with the default allocations.						*1	
		1	Change the sequence input signal allocations.							
		2	Reserved setting (Do not use.)							
	n.□□□□		/S-ON (Servo ON) Signal Allocation							Reference
		0	Active when CN1-40 input signal is ON (closed).						page 6-3	
		1	Active when CN1-41 input signal is ON (closed).							
		2	Active when CN1-42 input signal is ON (closed).							
		3	Active when CN1-43 input signal is ON (closed).							
		4	Active when CN1-44 input signal is ON (closed).							
		5	Active when CN1-45 input signal is ON (closed).							
		6	Active when CN1-46 input signal is ON (closed).							
		7	The signal is always active.							
		8	The signal is always inactive.							
		9	Active when CN1-40 input signal is OFF (open).							
		A	Active when CN1-41 input signal is OFF (open).							
		B	Active when CN1-42 input signal is OFF (open).							
		C	Active when CN1-43 input signal is OFF (open).							
		D	Active when CN1-44 input signal is OFF (open).							
	E	Active when CN1-45 input signal is OFF (open).								
	F	Active when CN1-46 input signal is OFF (open).								
n.□X□□		/P-CON (Proportional Control) Signal Allocation							Reference	
	0 to F	The allocations are the same as the /S-ON (Servo ON) signal allocations.						page 6-3		
n.X□□□		P-OT (Forward Drive Prohibit) Signal Allocation							Reference	
	0	Enable forward drive when CN1-40 input signal is ON (closed).						page 6-3		
	1	Enable forward drive when CN1-41 input signal is ON (closed).								
	2	Enable forward drive when CN1-42 input signal is ON (closed).								
	3	Enable forward drive when CN1-43 input signal is ON (closed).								
	4	Enable forward drive when CN1-44 input signal is ON (closed).								
	5	Enable forward drive when CN1-45 input signal is ON (closed).								
	6	Enable forward drive when CN1-46 input signal is ON (closed).								
	7	Set the signal to always prohibit forward drive.								
	8	Set the signal to always enable forward drive.								
	9	Enable forward drive when CN1-40 input signal is OFF (open).								
	A	Enable forward drive when CN1-41 input signal is OFF (open).								
	B	Enable forward drive when CN1-42 input signal is OFF (open).								
	C	Enable forward drive when CN1-43 input signal is OFF (open).								
	D	Enable forward drive when CN1-44 input signal is OFF (open).								
	E	Enable forward drive when CN1-45 input signal is OFF (open).								
	F	Enable forward drive when CN1-46 input signal is OFF (open).								

Continued on next page.

Continued from previous page.

Parameter No.	Size	Name	Setting Range	Setting Unit	Default Setting	Applicable Motors	When Enabled	Classification	Reference	
Pn50B	2	Input Signal Selections	0000 to FFFF	–	8868	All	After restart	Setup	–	
			N-OT (Reverse Drive Prohibit) Signal Allocation						Reference	
		n.□□□X	0	Enable reverse drive when CN1-40 input signal is ON (closed).						page 6-3
			1	Enable reverse drive when CN1-41 input signal is ON (closed).						
			2	Enable reverse drive when CN1-42 input signal is ON (closed).						
			3	Enable reverse drive when CN1-43 input signal is ON (closed).						
			4	Enable reverse drive when CN1-44 input signal is ON (closed).						
			5	Enable reverse drive when CN1-45 input signal is ON (closed).						
			6	Enable reverse drive when CN1-46 input signal is ON (closed).						
			7	Set the signal to always prohibit reverse drive.						
			8	Set the signal to always enable reverse drive.						
			9	Enable reverse drive when CN1-40 input signal is OFF (open).						
			A	Enable reverse drive when CN1-41 input signal is OFF (open).						
			B	Enable reverse drive when CN1-42 input signal is OFF (open).						
			C	Enable reverse drive when CN1-43 input signal is OFF (open).						
			D	Enable reverse drive when CN1-44 input signal is OFF (open).						
			E	Enable reverse drive when CN1-45 input signal is OFF (open).						
			F	Enable reverse drive when CN1-46 input signal is OFF (open).						
			/ALM-RST (Alarm Reset) Signal Allocation						Reference	
		n.□□X□	0	Active on signal edge when CN1-40 input signal changes from OFF (open) to ON (closed).						page 6-3
			1	Active on signal edge when CN1-41 input signal changes from OFF (open) to ON (closed).						
			2	Active on signal edge when CN1-42 input signal changes from OFF (open) to ON (closed).						
			3	Active on signal edge when CN1-43 input signal changes from OFF (open) to ON (closed).						
			4	Active on signal edge when CN1-44 input signal changes from OFF (open) to ON (closed).						
			5	Active on signal edge when CN1-45 input signal changes from OFF (open) to ON (closed).						
			6	Active on signal edge when CN1-46 input signal changes from OFF (open) to ON (closed).						
			7	Reserved setting (Do not use.)						
		8	The signal is always inactive.							
		9	Active on signal edge when CN1-40 input signal changes from ON (closed) to OFF (open).							
		A	Active on signal edge when CN1-41 input signal changes from ON (closed) to OFF (open).							
		B	Active on signal edge when CN1-42 input signal changes from ON (closed) to OFF (open).							
		C	Active on signal edge when CN1-43 input signal changes from ON (closed) to OFF (open).							
		D	Active on signal edge when CN1-44 input signal changes from ON (closed) to OFF (open).							
		E	Active on signal edge when CN1-45 input signal changes from ON (closed) to OFF (open).							
		F	Active on signal edge when CN1-46 input signal changes from ON (closed) to OFF (open).							
	n.□X□□	/P-CL (Forward External Torque Limit Input) Signal Allocation						Reference		
		0 to F	The allocations are the same as the /S-ON (Servo ON) signal allocations.						page 6-3	
	n.X□□□	/N-CL (Reverse External Torque Limit Input) Signal Allocation						Reference		
		0 to F	The allocations are the same as the /S-ON (Servo ON) signal allocations.						page 6-3	

Continued on next page.

9.2 List of Parameters

9.2.2 List of Parameters

Continued from previous page.

Parameter No.	Size	Name	Setting Range	Setting Unit	Default Setting	Applicable Motors	When Enabled	Classification	Reference	
Pn50C	2	Input Signal Selections	0000 to FFFF	–	8888	All	After restart	Setup	–	
	n.□□□X	/SPD-D (Motor Direction) Signal Allocation							Reference	page 6-3
		0	Active when CN1-40 input signal is ON (closed).							
		1	Active when CN1-41 input signal is ON (closed).							
		2	Active when CN1-42 input signal is ON (closed).							
		3	Active when CN1-43 input signal is ON (closed).							
		4	Active when CN1-44 input signal is ON (closed).							
		5	Active when CN1-45 input signal is ON (closed).							
		6	Active when CN1-46 input signal is ON (closed).							
		7	The signal is always active.							
		8	The signal is always inactive.							
		9	Active when CN1-40 input signal is OFF (open).							
		A	Active when CN1-41 input signal is OFF (open).							
		B	Active when CN1-42 input signal is OFF (open).							
		C	Active when CN1-43 input signal is OFF (open).							
D	Active when CN1-44 input signal is OFF (open).									
E	Active when CN1-45 input signal is OFF (open).									
F	Active when CN1-46 input signal is OFF (open).									
n.□□X□	/SPD-A (Internal Set Speed Selection Input) Signal Allocation							Reference	page 6-3	
0 to F	The allocations are the same as the /SPD-D (Motor Direction) signal allocations.									
n.□X□□	/SPD-B (Internal Set Speed Selection Input) Signal Allocation							Reference	page 6-3	
0 to F	The allocations are the same as the /SPD-D (Motor Direction) signal allocations.									
n.X□□□	/C-SEL (Control Selection Input) Signal Allocation							Reference	page 6-3	
0 to F	The allocations are the same as the /SPD-D (Motor Direction) signal allocations.									

Continued on next page.

Continued from previous page.

Parameter No.	Size	Name	Setting Range	Setting Unit	Default Setting	Applicable Motors	When Enabled	Classification	Reference
Pn50D	2	Input Signal Selections	0000 to FFFF	-	0888	-	After restart	Setup	-
		/ZCLAMP (Zero Clamping Input) Signal Allocation							
		n.□□□X	0	Active when CN1-40 input signal is ON (closed).	All	page 6-3			
			1	Active when CN1-41 input signal is ON (closed).					
			2	Active when CN1-42 input signal is ON (closed).					
			3	Active when CN1-43 input signal is ON (closed).					
			4	Active when CN1-44 input signal is ON (closed).					
			5	Active when CN1-45 input signal is ON (closed).					
			6	Active when CN1-46 input signal is ON (closed).					
			7	The signal is always active.					
			8	The signal is always inactive.					
			9	Active when CN1-40 input signal is OFF (open).					
			A	Active when CN1-41 input signal is OFF (open).					
			B	Active when CN1-42 input signal is OFF (open).					
			C	Active when CN1-43 input signal is OFF (open).					
			D	Active when CN1-44 input signal is OFF (open).					
		E	Active when CN1-45 input signal is OFF (open).						
		F	Active when CN1-46 input signal is OFF (open).						
			/INHIBIT (Reference Pulse Inhibit Input) Signal Allocation						
		n.□□X□	0 to F	The allocations are the same as the /ZCLAMP (Zero Clamping Input) signal allocations.	All	page 6-3			
		/G-SEL (Gain Selection Input) Signal Allocation							
	n.□X□□	0 to F	The allocations are the same as the /ZCLAMP (Zero Clamping Input) signal allocations.	All	page 6-3				
		/P-DET (Polarity Detection Input) Signal Allocation							
	n.X□□□	0 to F	The allocations are the same as the /ZCLAMP (Zero Clamping Input) signal allocations.	Linear	page 6-3				

Continued on next page.

9.2 List of Parameters

9.2.2 List of Parameters

Continued from previous page.

Parameter No.	Size	Name	Setting Range	Setting Unit	Default Setting	Applicable Motors	When Enabled	Classification	Reference	
Pn50E	2	Output Signal Selections 1	0000 to 6666	–	2011	All	After restart	Setup	–	
	n.□□□X	/COIN (Positioning Completion Output) Signal Allocation				Reference				
		0	Disabled (the above signal output is not used).				page 6-5			
		1	Output the signal from the CN1-25 or CN1-26 output terminal.							
		2	Output the signal from the CN1-27 or CN1-28 output terminal.							
		3	Output the signal from the CN1-29 or CN1-30 output terminal.							
		4	Output the signal from the CN1-37 output terminal.							
		5	Output the signal from the CN1-38 output terminal.							
	6	Output the signal from the CN1-39 output terminal.								
	n.□□X□	/V-CMP (Speed Coincidence Detection Output) Signal Allocation				Reference				
		0 to 6	The allocations are the same as the /COIN (Positioning Completion) signal allocations.				page 6-5			
	n.□X□□	/TGON (Rotation Detection Output) Signal Allocation				Reference				
		0 to 6	The allocations are the same as the /COIN (Positioning Completion) signal allocations.				page 6-5			
	n.X□□□	/S-RDY (Servo Ready) Signal Allocation				Reference				
		0 to 6	The allocations are the same as the /COIN (Positioning Completion) signal allocations.				page 6-5			
Pn50F	2	Output Signal Selections 2	0000 to 6666	–	0300	All	After restart	Setup	–	
	n.□□□X	/CLT (Torque Limit Detection Output) Signal Allocation				Reference				
		0	Disabled (the above signal output is not used).				page 6-5			
		1	Output the signal from the CN1-25 or CN1-26 output terminal.							
		2	Output the signal from the CN1-27 or CN1-28 output terminal.							
		3	Output the signal from the CN1-29 or CN1-30 output terminal.							
		4	Output the signal from the CN1-37 output terminal.							
		5	Output the signal from the CN1-38 output terminal.							
	6	Output the signal from the CN1-39 output terminal.								
	n.□□X□	/VLT (Speed Limit Detection) Signal Allocation				Reference				
		0 to 6	The allocations are the same as the /CLT (Torque Limit Detection Output) signal allocations.				page 6-5			
	n.□X□□	/BK (Brake Output) Signal Allocation				Reference				
		0 to 6	The allocations are the same as the /CLT (Torque Limit Detection Output) signal allocations.				page 6-5			
	n.X□□□	/WARN (Warning Output) Signal Allocation				Reference				
		0 to 6	The allocations are the same as the /CLT (Torque Limit Detection Output) signal allocations.				page 6-5			

Continued on next page.

Continued from previous page.

Parameter No.	Size	Name	Setting Range	Setting Unit	Default Setting	Applicable Motors	When Enabled	Classification	Reference	
Pn510	2	Output Signal Selections 3	0000 to 0666	-	0000	All	After restart	Setup	-	
			/NEAR (Near Output) Signal Allocation							Reference
	n.□□□X		0	Disabled (the above signal output is not used).						page 6-5
			1	Output the signal from the CN1-25 or CN1-26 output terminal.						
			2	Output the signal from the CN1-27 or CN1-28 output terminal.						
			3	Output the signal from the CN1-29 or CN1-30 output terminal.						
			4	Output the signal from the CN1-37 output terminal.						
			5	Output the signal from the CN1-38 output terminal.						
			6	Output the signal from the CN1-39 output terminal.						
	n.□□X□		Reserved parameter (Do not change.)							
		/PSELA (Reference Pulse Input Multiplication Switching Output) Signal Allocation							Reference	
n.□X□□		0 to 6	The allocations are the same as the /NEAR (Near) signal allocations.						page 6-5	
n.X□□□		Reserved parameter (Do not change.)								
Pn512	2	Output Signal Inverse Settings	0000 to 1111	-	0000	All	After restart	Setup	-	
	n.□□□X		Output Signal Inversion for CN1-25 and CN1-26 Terminals							
			0	The signal is not inverted.						
			1	The signal is inverted.						
	n.□□X□		Output Signal Inversion for CN1-27 and CN1-28 Terminals							
			0	The signal is not inverted.						
			1	The signal is inverted.						
	n.□X□□		Output Signal Inversion for CN1-29 and CN1-30 Terminals							
			0	The signal is not inverted.						
			1	The signal is inverted.						
n.X□□□		Output Signal Inversion for CN1-37 Terminal								
		0	The signal is not inverted.							
		1	The signal is inverted.							
Pn513	2	Output Signal Inverse Settings 2	0000 to 0011	-	0000	All	After restart	Setup	-	
	n.□□□X		Output Signal Inversion for CN1-38 Terminal							
			0	The signal is not inverted.						
			1	The signal is inverted.						
	n.□□X□		Output Signal Inversion for CN1-39 Terminal							
			0	The signal is not inverted.						
		1	The signal is inverted.							
n.□X□□		Reserved parameter (Do not change.)								
n.X□□□		Reserved parameter (Do not change.)								

Continued on next page.

9.2 List of Parameters

9.2.2 List of Parameters

Continued from previous page.

Parameter No.	Size	Name	Setting Range	Setting Unit	Default Setting	Applicable Motors	When Enabled	Classification	Reference	
Pn514	2	Output Signal Selections 4	0000 to 0666	-	0000	All	After restart	Setup	-	
		n.□□□X	Reserved parameter (Do not change.)							
		n.□□X□	Reserved parameter (Do not change.)							
		n.□X□□	/PM (Preventative Maintenance Output) Signal Allocation							Reference
			0	Disabled (the above signal output is not used).						page 6-5
			1	Output the signal from the CN1-25 or CN1-26 output terminal.						
			2	Output the signal from the CN1-27 or CN1-28 output terminal.						
			3	Output the signal from the CN1-29 or CN1-30 output terminal.						
			4	Output the signal from the CN1-37 output terminal.						
			5	Output the signal from the CN1-38 output terminal.						
	6	Output the signal from the CN1-39 output terminal.								
	n.X□□□	Reserved parameter (Do not change.)								

Continued on next page.

Continued from previous page.

Parameter No.	Size	Name	Setting Range	Setting Unit	Default Setting	Applicable Motors	When Enabled	Classification	Reference																																				
Pn515	2	Input Signal Selections	0000 to FFFF	–	8888	All	After restart	Setup	–																																				
		n.□□□X	<table border="1"> <thead> <tr> <th colspan="2">SEN (Absolute Data Request Input) Signal Allocation</th> <th>Reference</th> </tr> </thead> <tbody> <tr><td>0</td><td>Active when CN1-40 input signal is ON (closed).</td><td rowspan="16">page 6-3</td></tr> <tr><td>1</td><td>Active when CN1-41 input signal is ON (closed).</td></tr> <tr><td>2</td><td>Active when CN1-42 input signal is ON (closed).</td></tr> <tr><td>3</td><td>Active when CN1-43 input signal is ON (closed).</td></tr> <tr><td>4</td><td>Active when CN1-44 input signal is ON (closed).</td></tr> <tr><td>5</td><td>Active when CN1-45 input signal is ON (closed).</td></tr> <tr><td>6</td><td>Active when CN1-46 input signal is ON (closed).</td></tr> <tr><td>7</td><td>The signal is always active.</td></tr> <tr><td>8</td><td>Enable when 5 V is input to CN1-4.</td></tr> <tr><td>9</td><td>Active when CN1-40 input signal is OFF (open).</td></tr> <tr><td>A</td><td>Active when CN1-41 input signal is OFF (open).</td></tr> <tr><td>B</td><td>Active when CN1-42 input signal is OFF (open).</td></tr> <tr><td>C</td><td>Active when CN1-43 input signal is OFF (open).</td></tr> <tr><td>D</td><td>Active when CN1-44 input signal is OFF (open).</td></tr> <tr><td>E</td><td>Active when CN1-45 input signal is OFF (open).</td></tr> <tr><td>F</td><td>Active when CN1-46 input signal is OFF (open).</td></tr> </tbody> </table>							SEN (Absolute Data Request Input) Signal Allocation		Reference	0	Active when CN1-40 input signal is ON (closed).	page 6-3	1	Active when CN1-41 input signal is ON (closed).	2	Active when CN1-42 input signal is ON (closed).	3	Active when CN1-43 input signal is ON (closed).	4	Active when CN1-44 input signal is ON (closed).	5	Active when CN1-45 input signal is ON (closed).	6	Active when CN1-46 input signal is ON (closed).	7	The signal is always active.	8	Enable when 5 V is input to CN1-4.	9	Active when CN1-40 input signal is OFF (open).	A	Active when CN1-41 input signal is OFF (open).	B	Active when CN1-42 input signal is OFF (open).	C	Active when CN1-43 input signal is OFF (open).	D	Active when CN1-44 input signal is OFF (open).	E	Active when CN1-45 input signal is OFF (open).	F	Active when CN1-46 input signal is OFF (open).
	SEN (Absolute Data Request Input) Signal Allocation		Reference																																										
	0	Active when CN1-40 input signal is ON (closed).	page 6-3																																										
	1	Active when CN1-41 input signal is ON (closed).																																											
	2	Active when CN1-42 input signal is ON (closed).																																											
	3	Active when CN1-43 input signal is ON (closed).																																											
	4	Active when CN1-44 input signal is ON (closed).																																											
	5	Active when CN1-45 input signal is ON (closed).																																											
	6	Active when CN1-46 input signal is ON (closed).																																											
	7	The signal is always active.																																											
	8	Enable when 5 V is input to CN1-4.																																											
	9	Active when CN1-40 input signal is OFF (open).																																											
	A	Active when CN1-41 input signal is OFF (open).																																											
	B	Active when CN1-42 input signal is OFF (open).																																											
	C	Active when CN1-43 input signal is OFF (open).																																											
	D	Active when CN1-44 input signal is OFF (open).																																											
	E	Active when CN1-45 input signal is OFF (open).																																											
	F	Active when CN1-46 input signal is OFF (open).																																											
		n.□□X□	<table border="1"> <thead> <tr> <th colspan="2">/PSEL (Reference Pulse Input Multiplication Switching Input) Signal Allocation</th> <th>Reference</th> </tr> </thead> <tbody> <tr><td>0</td><td>Active when CN1-40 input signal is ON (closed).</td><td rowspan="16">page 6-3</td></tr> <tr><td>1</td><td>Active when CN1-41 input signal is ON (closed).</td></tr> <tr><td>2</td><td>Active when CN1-42 input signal is ON (closed).</td></tr> <tr><td>3</td><td>Active when CN1-43 input signal is ON (closed).</td></tr> <tr><td>4</td><td>Active when CN1-44 input signal is ON (closed).</td></tr> <tr><td>5</td><td>Active when CN1-45 input signal is ON (closed).</td></tr> <tr><td>6</td><td>Active when CN1-46 input signal is ON (closed).</td></tr> <tr><td>7</td><td>The signal is always enabled.</td></tr> <tr><td>8</td><td>The signal is always inactive.</td></tr> <tr><td>9</td><td>Active when CN1-40 input signal is OFF (open).</td></tr> <tr><td>A</td><td>Active when CN1-41 input signal is OFF (open).</td></tr> <tr><td>B</td><td>Active when CN1-42 input signal is OFF (open).</td></tr> <tr><td>C</td><td>Active when CN1-43 input signal is OFF (open).</td></tr> <tr><td>D</td><td>Active when CN1-44 input signal is OFF (open).</td></tr> <tr><td>E</td><td>Active when CN1-45 input signal is OFF (open).</td></tr> <tr><td>F</td><td>Active when CN1-46 input signal is OFF (open).</td></tr> </tbody> </table>							/PSEL (Reference Pulse Input Multiplication Switching Input) Signal Allocation		Reference	0	Active when CN1-40 input signal is ON (closed).	page 6-3	1	Active when CN1-41 input signal is ON (closed).	2	Active when CN1-42 input signal is ON (closed).	3	Active when CN1-43 input signal is ON (closed).	4	Active when CN1-44 input signal is ON (closed).	5	Active when CN1-45 input signal is ON (closed).	6	Active when CN1-46 input signal is ON (closed).	7	The signal is always enabled.	8	The signal is always inactive.	9	Active when CN1-40 input signal is OFF (open).	A	Active when CN1-41 input signal is OFF (open).	B	Active when CN1-42 input signal is OFF (open).	C	Active when CN1-43 input signal is OFF (open).	D	Active when CN1-44 input signal is OFF (open).	E	Active when CN1-45 input signal is OFF (open).	F	Active when CN1-46 input signal is OFF (open).
	/PSEL (Reference Pulse Input Multiplication Switching Input) Signal Allocation		Reference																																										
	0	Active when CN1-40 input signal is ON (closed).	page 6-3																																										
	1	Active when CN1-41 input signal is ON (closed).																																											
	2	Active when CN1-42 input signal is ON (closed).																																											
	3	Active when CN1-43 input signal is ON (closed).																																											
	4	Active when CN1-44 input signal is ON (closed).																																											
	5	Active when CN1-45 input signal is ON (closed).																																											
6	Active when CN1-46 input signal is ON (closed).																																												
7	The signal is always enabled.																																												
8	The signal is always inactive.																																												
9	Active when CN1-40 input signal is OFF (open).																																												
A	Active when CN1-41 input signal is OFF (open).																																												
B	Active when CN1-42 input signal is OFF (open).																																												
C	Active when CN1-43 input signal is OFF (open).																																												
D	Active when CN1-44 input signal is OFF (open).																																												
E	Active when CN1-45 input signal is OFF (open).																																												
F	Active when CN1-46 input signal is OFF (open).																																												
	n.□X□□	Reserved parameter (Do not change.)																																											
	n.X□□□	Reserved parameter (Do not change.)																																											

Continued on next page.

9.2 List of Parameters

9.2.2 List of Parameters

Continued from previous page.

Parameter No.	Size	Name	Setting Range	Setting Unit	Default Setting	Applicable Motors	When Enabled	Classification	Reference																																				
Pn516	2	Input Signal Selections 7	0000 to FFFF	-	8888	All	After restart	Setup	-																																				
	n.□□□X		<table border="1"> <thead> <tr> <th colspan="2">FSTP (Forced Stop Input) Signal Allocation</th> <th>Reference</th> </tr> </thead> <tbody> <tr><td>0</td><td>Enable drive when CN1-40 input signal is ON (closed).</td><td rowspan="16">page 6-3</td></tr> <tr><td>1</td><td>Enable drive when CN1-41 input signal is ON (closed).</td></tr> <tr><td>2</td><td>Enable drive when CN1-42 input signal is ON (closed).</td></tr> <tr><td>3</td><td>Enable drive when CN1-43 input signal is ON (closed).</td></tr> <tr><td>4</td><td>Enable drive when CN1-44 input signal is ON (closed).</td></tr> <tr><td>5</td><td>Enable drive when CN1-45 input signal is ON (closed).</td></tr> <tr><td>6</td><td>Enable drive when CN1-46 input signal is ON (closed).</td></tr> <tr><td>7</td><td>Set the signal to always prohibit drive (always force the motor to stop).</td></tr> <tr><td>8</td><td>Set the signal to always enable drive (always disable forcing the motor to stop).</td></tr> <tr><td>9</td><td>Enable drive when CN1-40 input signal is OFF (open).</td></tr> <tr><td>A</td><td>Enable drive when CN1-41 input signal is OFF (open).</td></tr> <tr><td>B</td><td>Enable drive when CN1-42 input signal is OFF (open).</td></tr> <tr><td>C</td><td>Enable drive when CN1-43 input signal is OFF (open).</td></tr> <tr><td>D</td><td>Enable drive when CN1-44 input signal is OFF (open).</td></tr> <tr><td>E</td><td>Enable drive when CN1-45 input signal is OFF (open).</td></tr> <tr><td>F</td><td>Enable drive when CN1-46 input signal is OFF (open).</td></tr> </tbody> </table>							FSTP (Forced Stop Input) Signal Allocation		Reference	0	Enable drive when CN1-40 input signal is ON (closed).	page 6-3	1	Enable drive when CN1-41 input signal is ON (closed).	2	Enable drive when CN1-42 input signal is ON (closed).	3	Enable drive when CN1-43 input signal is ON (closed).	4	Enable drive when CN1-44 input signal is ON (closed).	5	Enable drive when CN1-45 input signal is ON (closed).	6	Enable drive when CN1-46 input signal is ON (closed).	7	Set the signal to always prohibit drive (always force the motor to stop).	8	Set the signal to always enable drive (always disable forcing the motor to stop).	9	Enable drive when CN1-40 input signal is OFF (open).	A	Enable drive when CN1-41 input signal is OFF (open).	B	Enable drive when CN1-42 input signal is OFF (open).	C	Enable drive when CN1-43 input signal is OFF (open).	D	Enable drive when CN1-44 input signal is OFF (open).	E	Enable drive when CN1-45 input signal is OFF (open).	F	Enable drive when CN1-46 input signal is OFF (open).
	FSTP (Forced Stop Input) Signal Allocation		Reference																																										
	0	Enable drive when CN1-40 input signal is ON (closed).	page 6-3																																										
	1	Enable drive when CN1-41 input signal is ON (closed).																																											
	2	Enable drive when CN1-42 input signal is ON (closed).																																											
	3	Enable drive when CN1-43 input signal is ON (closed).																																											
	4	Enable drive when CN1-44 input signal is ON (closed).																																											
	5	Enable drive when CN1-45 input signal is ON (closed).																																											
	6	Enable drive when CN1-46 input signal is ON (closed).																																											
	7	Set the signal to always prohibit drive (always force the motor to stop).																																											
	8	Set the signal to always enable drive (always disable forcing the motor to stop).																																											
	9	Enable drive when CN1-40 input signal is OFF (open).																																											
	A	Enable drive when CN1-41 input signal is OFF (open).																																											
	B	Enable drive when CN1-42 input signal is OFF (open).																																											
	C	Enable drive when CN1-43 input signal is OFF (open).																																											
	D	Enable drive when CN1-44 input signal is OFF (open).																																											
	E	Enable drive when CN1-45 input signal is OFF (open).																																											
	F	Enable drive when CN1-46 input signal is OFF (open).																																											
	n.□□□□	Reserved parameter (Do not change.)																																											
n.□X□□	Reserved parameter (Do not change.)																																												
n.X□□□	Reserved parameter (Do not change.)																																												
Pn517	2	Output Signal Selections 5	0000 to 0666	-	0000	All	After restart	Setup	*1																																				
	n.□□□X		<table border="1"> <thead> <tr> <th colspan="2">ALO1 (Alarm Code Output) Signal Allocation</th> </tr> </thead> <tbody> <tr><td>0</td><td>Disabled (the above signal output is not used).</td></tr> <tr><td>1</td><td>Output the signal from the CN1-25 or CN1-26 output terminal.</td></tr> <tr><td>2</td><td>Output the signal from the CN1-27 or CN1-28 output terminal.</td></tr> <tr><td>3</td><td>Output the signal from the CN1-29 or CN1-30 output terminal.</td></tr> <tr><td>4</td><td>Output the signal from the CN1-37 output terminal.</td></tr> <tr><td>5</td><td>Output the signal from the CN1-38 output terminal.</td></tr> <tr><td>6</td><td>Output the signal from the CN1-39 output terminal.</td></tr> </tbody> </table>							ALO1 (Alarm Code Output) Signal Allocation		0	Disabled (the above signal output is not used).	1	Output the signal from the CN1-25 or CN1-26 output terminal.	2	Output the signal from the CN1-27 or CN1-28 output terminal.	3	Output the signal from the CN1-29 or CN1-30 output terminal.	4	Output the signal from the CN1-37 output terminal.	5	Output the signal from the CN1-38 output terminal.	6	Output the signal from the CN1-39 output terminal.																				
	ALO1 (Alarm Code Output) Signal Allocation																																												
	0	Disabled (the above signal output is not used).																																											
	1	Output the signal from the CN1-25 or CN1-26 output terminal.																																											
	2	Output the signal from the CN1-27 or CN1-28 output terminal.																																											
	3	Output the signal from the CN1-29 or CN1-30 output terminal.																																											
	4	Output the signal from the CN1-37 output terminal.																																											
	5	Output the signal from the CN1-38 output terminal.																																											
	6	Output the signal from the CN1-39 output terminal.																																											
n.□□□□		<table border="1"> <thead> <tr> <th colspan="2">ALO2 (Alarm Code Output) Signal Allocation</th> </tr> </thead> <tbody> <tr> <td>0 to 6</td> <td>The allocations are the same as the ALO1 (Alarm Code Output) signal allocations.</td> </tr> </tbody> </table>								ALO2 (Alarm Code Output) Signal Allocation		0 to 6	The allocations are the same as the ALO1 (Alarm Code Output) signal allocations.																																
ALO2 (Alarm Code Output) Signal Allocation																																													
0 to 6	The allocations are the same as the ALO1 (Alarm Code Output) signal allocations.																																												
n.□X□□		<table border="1"> <thead> <tr> <th colspan="2">ALO3 (Alarm Code Output) Signal Allocation</th> </tr> </thead> <tbody> <tr> <td>0 to 6</td> <td>The allocations are the same as the ALO1 (Alarm Code Output) signal allocations.</td> </tr> </tbody> </table>								ALO3 (Alarm Code Output) Signal Allocation		0 to 6	The allocations are the same as the ALO1 (Alarm Code Output) signal allocations.																																
ALO3 (Alarm Code Output) Signal Allocation																																													
0 to 6	The allocations are the same as the ALO1 (Alarm Code Output) signal allocations.																																												
n.X□□□		Reserved parameter (Do not change.)																																											
Pn518*3	-	Safety Module-Related Parameters	-	-	-	All	-	-	-																																				

Continued on next page.

Continued from previous page.

Parameter No.	Size	Name	Setting Range	Setting Unit	Default Setting	Applicable Motors	When Enabled	Classification	Reference		
Pn51B	4	Motor-Load Position Deviation Overflow Detection Level	0 to 1,073,741,824	1 reference unit	1000	Rotary	Immediately	Setup	*1		
Pn51E	2	Position Deviation Overflow Warning Level	10 to 100	1%	100	All	Immediately	Setup	*1		
Pn520	4	Position Deviation Overflow Alarm Level	1 to 1,073,741,823	1 reference unit	5242880	All	Immediately	Setup	*1		
Pn522	4	Positioning Completed Width	0 to 1,073,741,824	1 reference unit	7	All	Immediately	Setup	*1		
Pn524	4	Near Signal Width	1 to 1,073,741,824	1 reference unit	1073741824	All	Immediately	Setup	*1		
Pn526	4	Position Deviation Overflow Alarm Level at Servo ON	1 to 1,073,741,823	1 reference unit	5242880	All	Immediately	Setup	*1		
Pn528	2	Position Deviation Overflow Warning Level at Servo ON	10 to 100	1%	100	All	Immediately	Setup	*1		
Pn529	2	Speed Limit Level at Servo ON	0 to 10,000	1 min ⁻¹	10000	Rotary	Immediately	Setup	*1		
Pn52A	2	Multiplier per Fully-closed Rotation	0 to 100	1%	20	Rotary	Immediately	Tuning	*1		
Pn52B	2	Overload Warning Level	1 to 100	1%	20	All	Immediately	Setup	*1		
Pn52C	2	Base Current Derating at Motor Overload Detection	10 to 100	1%	100	All	After restart	Setup	*1		
Pn52D	2	Reserved parameter (Do not change.)	–	–	50	All	–	–	–		
Pn52F	2	Monitor Display at Startup	0000 to OFFF	–	OFFF	All	Immediately	Setup	*1		
Pn530	2	Program Jog Operation-Related Selections	0000 to 0005	–	0000	All	Immediately	Setup	*1		
										Program Jog Operation Pattern	
										0	(Waiting time in Pn535 → Forward by travel distance in Pn531) × Number of movements in Pn536
										1	(Waiting time in Pn535 → Reverse by travel distance in Pn531) × Number of movements in Pn536
										2	(Waiting time in Pn535 → Forward by travel distance in Pn531) × Number of movements in Pn536 (Waiting time in Pn535 → Reverse by travel distance in Pn531) × Number of movements in Pn536
										3	(Waiting time in Pn535 → Reverse by travel distance in Pn531) × Number of movements in Pn536 (Waiting time in Pn535 → Forward by travel distance in Pn531) × Number of movements in Pn536
										4	(Waiting time in Pn535 → Forward by travel distance in Pn531 → Waiting time in Pn535 → Reserve by travel distance in Pn531) × Number of movements in Pn536
		5	(Waiting time in Pn535 → Reverse by travel distance in Pn531 → Waiting time in Pn535 → Forward by travel distance in Pn531) × Number of movements in Pn536								
		n.□□□□	Reserved parameter (Do not change.)								
		n.□X□□	Reserved parameter (Do not change.)								
n.X□□□	Reserved parameter (Do not change.)										

Continued on next page.

9.2 List of Parameters

9.2.2 List of Parameters

Continued from previous page.

Parameter No.	Size	Name	Setting Range	Setting Unit	Default Setting	Applicable Motors	When Enabled	Classification	Reference
Pn533	2	Program Jog Operation Movement Speed	1 to 10,000	Rotary: 1 min ⁻¹ Direct Drive: 0.1 min ⁻¹	500	Rotary	Immediately	Setup	*1
Pn534	2	Program Jog Operation Acceleration/Deceleration Time	2 to 10,000	1 ms	100	All	Immediately	Setup	*1
Pn535	2	Program Jog Operation Waiting Time	0 to 10,000	1 ms	100	All	Immediately	Setup	*1
Pn536	2	Program Jog Operation Number of Movements	0 to 1,000	Times	1	All	Immediately	Setup	*1
Pn550	2	Analog Monitor 1 Offset Voltage	-10,000 to 10,000	0.1 V	0	All	Immediately	Setup	*1
Pn551	2	Analog Monitor 2 Offset Voltage	-10,000 to 10,000	0.1 V	0	All	Immediately	Setup	*1
Pn552	2	Analog Monitor 1 Magnification	-10,000 to 10,000	× 0.01	100	All	Immediately	Setup	*1
Pn553	2	Analog Monitor 2 Magnification	-10,000 to 10,000	× 0.01	100	All	Immediately	Setup	*1
Pn55A	2	Power Consumption Monitor Unit Time	1 to 1,440	1 min	1	All	Immediately	Setup	–
Pn560	2	Residual Vibration Detection Width	1 to 3,000	0.1%	400	All	Immediately	Setup	–
Pn561	2	Overshoot Detection Level	0 to 100	1%	100	All	Immediately	Setup	–
Pn580	2	Zero Clamping Level	0 to 10,000	1 mm/s	10	Linear	Immediately	Setup	*1
Pn581	2	Zero Speed Level	1 to 10,000	1 mm/s	20	Linear	Immediately	Setup	*1
Pn582	2	Speed Coincidence Detection Signal Output Width	0 to 100	1 mm/s	10	Linear	Immediately	Setup	*1
Pn583	2	Brake Reference Output Speed Level	0 to 10,000	1 mm/s	10	Linear	Immediately	Setup	*1
Pn584	2	Speed Limit Level at Servo ON	0 to 10,000	1 mm/s	10000	Linear	Immediately	Setup	*1
Pn585	2	Program Jog Operation Movement Speed	1 to 10,000	1 mm/s	50	Linear	Immediately	Setup	*1
Pn586	2	Motor Running Cooling Ratio	0 to 100	1%/ Max. speed	0	Linear	Immediately	Setup	–
Pn600	2	Regenerative Resistor Capacity*4	Depends on model.*5	10 W	0	All	Immediately	Setup	–
Pn601	2	Dynamic Brake Resistor Allowable Energy Consumption	0 to 65,535	10 J	0	All	After restart	Setup	*6
Pn603	2	Regenerative Resistance	0 to 65,535	10 mΩ	0	All	Immediately	Setup	–
Pn604	2	Dynamic Brake Resistance	0 to 65,535	10 mΩ	0	All	After restart	Setup	*6
Pn621 to Pn628*3	–	Safety Module-Related Parameters	–	–	–	All	–	–	–

Continued on next page.

Continued from previous page.

Parameter No.	Size	Name	Setting Range	Setting Unit	Default Setting	Applicable Motors	When Enabled	Classification	Reference																																				
Pn630	2	Input Signal Selections 10	0000 to FFFF	–	6221	All	After restart	Setup	–																																				
			<table border="1"> <thead> <tr> <th colspan="2">/MODE 0/1 (Mode Switch Input) Signal Allocation</th> <th>Reference</th> </tr> </thead> <tbody> <tr> <td>0</td> <td>Mode 0 is used when CN1-40 input signal is ON (closed).</td> <td rowspan="16">page 6-3</td> </tr> <tr> <td>1</td> <td>Mode 0 is used when CN1-41 input signal is ON (closed).</td> </tr> <tr> <td>2</td> <td>Mode 0 is used when CN1-42 input signal is ON (closed).</td> </tr> <tr> <td>3</td> <td>Mode 0 is used when CN1-43 input signal is ON (closed).</td> </tr> <tr> <td>4</td> <td>Mode 0 is used when CN1-44 input signal is ON (closed).</td> </tr> <tr> <td>5</td> <td>Mode 0 is used when CN1-45 input signal is ON (closed).</td> </tr> <tr> <td>6</td> <td>Mode 0 is used when CN1-46 input signal is ON (closed).</td> </tr> <tr> <td>7</td> <td>The signal always specifies mode 0.</td> </tr> <tr> <td>8</td> <td>The signal always specifies mode 1.</td> </tr> <tr> <td>9</td> <td>Mode 0 is used when CN1-40 input signal is OFF (open).</td> </tr> <tr> <td>A</td> <td>Mode 0 is used when CN1-41 input signal is OFF (open).</td> </tr> <tr> <td>B</td> <td>Mode 0 is used when CN1-42 input signal is OFF (open).</td> </tr> <tr> <td>C</td> <td>Mode 0 is used when CN1-43 input signal is OFF (open).</td> </tr> <tr> <td>D</td> <td>Mode 0 is used when CN1-44 input signal is OFF (open).</td> </tr> <tr> <td>E</td> <td>Mode 0 is used when CN1-45 input signal is OFF (open).</td> </tr> <tr> <td>F</td> <td>Mode 0 is used when CN1-46 input signal is OFF (open).</td> </tr> </tbody> </table>							/MODE 0/1 (Mode Switch Input) Signal Allocation		Reference	0	Mode 0 is used when CN1-40 input signal is ON (closed).	page 6-3	1	Mode 0 is used when CN1-41 input signal is ON (closed).	2	Mode 0 is used when CN1-42 input signal is ON (closed).	3	Mode 0 is used when CN1-43 input signal is ON (closed).	4	Mode 0 is used when CN1-44 input signal is ON (closed).	5	Mode 0 is used when CN1-45 input signal is ON (closed).	6	Mode 0 is used when CN1-46 input signal is ON (closed).	7	The signal always specifies mode 0.	8	The signal always specifies mode 1.	9	Mode 0 is used when CN1-40 input signal is OFF (open).	A	Mode 0 is used when CN1-41 input signal is OFF (open).	B	Mode 0 is used when CN1-42 input signal is OFF (open).	C	Mode 0 is used when CN1-43 input signal is OFF (open).	D	Mode 0 is used when CN1-44 input signal is OFF (open).	E	Mode 0 is used when CN1-45 input signal is OFF (open).	F	Mode 0 is used when CN1-46 input signal is OFF (open).
	/MODE 0/1 (Mode Switch Input) Signal Allocation		Reference																																										
	0	Mode 0 is used when CN1-40 input signal is ON (closed).	page 6-3																																										
	1	Mode 0 is used when CN1-41 input signal is ON (closed).																																											
	2	Mode 0 is used when CN1-42 input signal is ON (closed).																																											
	3	Mode 0 is used when CN1-43 input signal is ON (closed).																																											
	4	Mode 0 is used when CN1-44 input signal is ON (closed).																																											
	5	Mode 0 is used when CN1-45 input signal is ON (closed).																																											
	6	Mode 0 is used when CN1-46 input signal is ON (closed).																																											
	7	The signal always specifies mode 0.																																											
	8	The signal always specifies mode 1.																																											
	9	Mode 0 is used when CN1-40 input signal is OFF (open).																																											
	A	Mode 0 is used when CN1-41 input signal is OFF (open).																																											
	B	Mode 0 is used when CN1-42 input signal is OFF (open).																																											
	C	Mode 0 is used when CN1-43 input signal is OFF (open).																																											
	D	Mode 0 is used when CN1-44 input signal is OFF (open).																																											
	E	Mode 0 is used when CN1-45 input signal is OFF (open).																																											
	F	Mode 0 is used when CN1-46 input signal is OFF (open).																																											
			<table border="1"> <thead> <tr> <th colspan="2">/START-STOP (Program Table Operation Start-Stop Input) Signal Allocation</th> <th>Reference</th> </tr> </thead> <tbody> <tr> <td>0</td> <td>Active when CN1-40 input signal is ON (closed).</td> <td rowspan="16">page 6-3</td> </tr> <tr> <td>1</td> <td>Active when CN1-41 input signal is ON (closed).</td> </tr> <tr> <td>2</td> <td>Active when CN1-42 input signal is ON (closed).</td> </tr> <tr> <td>3</td> <td>Active when CN1-43 input signal is ON (closed).</td> </tr> <tr> <td>4</td> <td>Active when CN1-44 input signal is ON (closed).</td> </tr> <tr> <td>5</td> <td>Active when CN1-45 input signal is ON (closed).</td> </tr> <tr> <td>6</td> <td>Active when CN1-46 input signal is ON (closed).</td> </tr> <tr> <td>7</td> <td>The signal is always active.</td> </tr> <tr> <td>8</td> <td>The signal is always inactive.</td> </tr> <tr> <td>9</td> <td>Active when CN1-40 input signal is OFF (open).</td> </tr> <tr> <td>A</td> <td>Active when CN1-41 input signal is OFF (open).</td> </tr> <tr> <td>B</td> <td>Active when CN1-42 input signal is OFF (open).</td> </tr> <tr> <td>C</td> <td>Active when CN1-43 input signal is OFF (open).</td> </tr> <tr> <td>D</td> <td>Active when CN1-44 input signal is OFF (open).</td> </tr> <tr> <td>E</td> <td>Active when CN1-45 input signal is OFF (open).</td> </tr> <tr> <td>F</td> <td>Active when CN1-46 input signal is OFF (open).</td> </tr> </tbody> </table>							/START-STOP (Program Table Operation Start-Stop Input) Signal Allocation		Reference	0	Active when CN1-40 input signal is ON (closed).	page 6-3	1	Active when CN1-41 input signal is ON (closed).	2	Active when CN1-42 input signal is ON (closed).	3	Active when CN1-43 input signal is ON (closed).	4	Active when CN1-44 input signal is ON (closed).	5	Active when CN1-45 input signal is ON (closed).	6	Active when CN1-46 input signal is ON (closed).	7	The signal is always active.	8	The signal is always inactive.	9	Active when CN1-40 input signal is OFF (open).	A	Active when CN1-41 input signal is OFF (open).	B	Active when CN1-42 input signal is OFF (open).	C	Active when CN1-43 input signal is OFF (open).	D	Active when CN1-44 input signal is OFF (open).	E	Active when CN1-45 input signal is OFF (open).	F	Active when CN1-46 input signal is OFF (open).
/START-STOP (Program Table Operation Start-Stop Input) Signal Allocation		Reference																																											
0	Active when CN1-40 input signal is ON (closed).	page 6-3																																											
1	Active when CN1-41 input signal is ON (closed).																																												
2	Active when CN1-42 input signal is ON (closed).																																												
3	Active when CN1-43 input signal is ON (closed).																																												
4	Active when CN1-44 input signal is ON (closed).																																												
5	Active when CN1-45 input signal is ON (closed).																																												
6	Active when CN1-46 input signal is ON (closed).																																												
7	The signal is always active.																																												
8	The signal is always inactive.																																												
9	Active when CN1-40 input signal is OFF (open).																																												
A	Active when CN1-41 input signal is OFF (open).																																												
B	Active when CN1-42 input signal is OFF (open).																																												
C	Active when CN1-43 input signal is OFF (open).																																												
D	Active when CN1-44 input signal is OFF (open).																																												
E	Active when CN1-45 input signal is OFF (open).																																												
F	Active when CN1-46 input signal is OFF (open).																																												
		<table border="1"> <thead> <tr> <th colspan="2">/HOME (Homing Input) Signal Allocation</th> <th>Reference</th> </tr> </thead> <tbody> <tr> <td>0 to F</td> <td>The settings are the same as for /START-STOP (Program Table Operation Start-Stop Input) Signal Allocation.</td> <td>page 6-3</td> </tr> </tbody> </table>							/HOME (Homing Input) Signal Allocation		Reference	0 to F	The settings are the same as for /START-STOP (Program Table Operation Start-Stop Input) Signal Allocation.	page 6-3																															
/HOME (Homing Input) Signal Allocation		Reference																																											
0 to F	The settings are the same as for /START-STOP (Program Table Operation Start-Stop Input) Signal Allocation.	page 6-3																																											
		<table border="1"> <thead> <tr> <th colspan="2">/PGMRES (Program Table Operation Reset Input) Signal Allocation</th> <th>Reference</th> </tr> </thead> <tbody> <tr> <td>0 to F</td> <td>The settings are the same as for /START-STOP (Program Table Operation Start-Stop Input) Signal Allocation.</td> <td>page 6-3</td> </tr> </tbody> </table>							/PGMRES (Program Table Operation Reset Input) Signal Allocation		Reference	0 to F	The settings are the same as for /START-STOP (Program Table Operation Start-Stop Input) Signal Allocation.	page 6-3																															
/PGMRES (Program Table Operation Reset Input) Signal Allocation		Reference																																											
0 to F	The settings are the same as for /START-STOP (Program Table Operation Start-Stop Input) Signal Allocation.	page 6-3																																											

Continued on next page.

9.2 List of Parameters

9.2.2 List of Parameters

Continued from previous page.

Parameter No.	Size	Name	Setting Range	Setting Unit	Default Setting	Applicable Motors	When Enabled	Classification	Reference																																				
Pn631	2	Input Signal Selections 11	0000 to FFFF	–	8543	All	After restart	Setup	–																																				
			<table border="1"> <thead> <tr> <th colspan="2">/SEL0 (Program Step Selection Input 0) Signal Allocation</th> <th>Reference</th> </tr> </thead> <tbody> <tr> <td>0</td> <td>Active when CN1-40 input signal is ON (closed).</td> <td rowspan="16">page 6-3</td> </tr> <tr> <td>1</td> <td>Active when CN1-41 input signal is ON (closed).</td> </tr> <tr> <td>2</td> <td>Active when CN1-42 input signal is ON (closed).</td> </tr> <tr> <td>3</td> <td>Active when CN1-43 input signal is ON (closed).</td> </tr> <tr> <td>4</td> <td>Active when CN1-44 input signal is ON (closed).</td> </tr> <tr> <td>5</td> <td>Active when CN1-45 input signal is ON (closed).</td> </tr> <tr> <td>6</td> <td>Active when CN1-46 input signal is ON (closed).</td> </tr> <tr> <td>7</td> <td>The signal is always active.</td> </tr> <tr> <td>8</td> <td>The signal is always inactive.</td> </tr> <tr> <td>9</td> <td>Active when CN1-40 input signal is OFF (open).</td> </tr> <tr> <td>A</td> <td>Active when CN1-41 input signal is OFF (open).</td> </tr> <tr> <td>B</td> <td>Active when CN1-42 input signal is OFF (open).</td> </tr> <tr> <td>C</td> <td>Active when CN1-43 input signal is OFF (open).</td> </tr> <tr> <td>D</td> <td>Active when CN1-44 input signal is OFF (open).</td> </tr> <tr> <td>E</td> <td>Active when CN1-45 input signal is OFF (open).</td> </tr> <tr> <td>F</td> <td>Active when CN1-46 input signal is OFF (open).</td> </tr> </tbody> </table>							/SEL0 (Program Step Selection Input 0) Signal Allocation		Reference	0	Active when CN1-40 input signal is ON (closed).	page 6-3	1	Active when CN1-41 input signal is ON (closed).	2	Active when CN1-42 input signal is ON (closed).	3	Active when CN1-43 input signal is ON (closed).	4	Active when CN1-44 input signal is ON (closed).	5	Active when CN1-45 input signal is ON (closed).	6	Active when CN1-46 input signal is ON (closed).	7	The signal is always active.	8	The signal is always inactive.	9	Active when CN1-40 input signal is OFF (open).	A	Active when CN1-41 input signal is OFF (open).	B	Active when CN1-42 input signal is OFF (open).	C	Active when CN1-43 input signal is OFF (open).	D	Active when CN1-44 input signal is OFF (open).	E	Active when CN1-45 input signal is OFF (open).	F	Active when CN1-46 input signal is OFF (open).
	/SEL0 (Program Step Selection Input 0) Signal Allocation		Reference																																										
	0	Active when CN1-40 input signal is ON (closed).	page 6-3																																										
	1	Active when CN1-41 input signal is ON (closed).																																											
	2	Active when CN1-42 input signal is ON (closed).																																											
	3	Active when CN1-43 input signal is ON (closed).																																											
	4	Active when CN1-44 input signal is ON (closed).																																											
	5	Active when CN1-45 input signal is ON (closed).																																											
	6	Active when CN1-46 input signal is ON (closed).																																											
	7	The signal is always active.																																											
	8	The signal is always inactive.																																											
	9	Active when CN1-40 input signal is OFF (open).																																											
	A	Active when CN1-41 input signal is OFF (open).																																											
	B	Active when CN1-42 input signal is OFF (open).																																											
	C	Active when CN1-43 input signal is OFF (open).																																											
	D	Active when CN1-44 input signal is OFF (open).																																											
	E	Active when CN1-45 input signal is OFF (open).																																											
	F	Active when CN1-46 input signal is OFF (open).																																											
			<table border="1"> <thead> <tr> <th colspan="2">/SEL1 (Program Step Selection Input 1) Signal Allocation</th> <th>Reference</th> </tr> </thead> <tbody> <tr> <td>n.□□X□</td> <td>0 to F</td> <td>The settings are the same as for /SEL0 (Program Step Selection Input 0) Signal Allocation.</td> <td>page 6-3</td> </tr> </tbody> </table>							/SEL1 (Program Step Selection Input 1) Signal Allocation		Reference	n.□□X□	0 to F	The settings are the same as for /SEL0 (Program Step Selection Input 0) Signal Allocation.	page 6-3																													
/SEL1 (Program Step Selection Input 1) Signal Allocation		Reference																																											
n.□□X□	0 to F	The settings are the same as for /SEL0 (Program Step Selection Input 0) Signal Allocation.	page 6-3																																										
		<table border="1"> <thead> <tr> <th colspan="2">/SEL2 (Program Step Selection Input 2) Signal Allocation</th> <th>Reference</th> </tr> </thead> <tbody> <tr> <td>n.□X□□</td> <td>0 to F</td> <td>The settings are the same as for /SEL0 (Program Step Selection Input 0) Signal Allocation.</td> <td>page 6-3</td> </tr> </tbody> </table>							/SEL2 (Program Step Selection Input 2) Signal Allocation		Reference	n.□X□□	0 to F	The settings are the same as for /SEL0 (Program Step Selection Input 0) Signal Allocation.	page 6-3																														
/SEL2 (Program Step Selection Input 2) Signal Allocation		Reference																																											
n.□X□□	0 to F	The settings are the same as for /SEL0 (Program Step Selection Input 0) Signal Allocation.	page 6-3																																										
		<table border="1"> <thead> <tr> <th colspan="2">/SEL3 (Program Step Selection Input 3) Signal Allocation</th> <th>Reference</th> </tr> </thead> <tbody> <tr> <td>n.X□□□</td> <td>0 to F</td> <td>The settings are the same as for /SEL0 (Program Step Selection Input 0) Signal Allocation.</td> <td>page 6-3</td> </tr> </tbody> </table>							/SEL3 (Program Step Selection Input 3) Signal Allocation		Reference	n.X□□□	0 to F	The settings are the same as for /SEL0 (Program Step Selection Input 0) Signal Allocation.	page 6-3																														
/SEL3 (Program Step Selection Input 3) Signal Allocation		Reference																																											
n.X□□□	0 to F	The settings are the same as for /SEL0 (Program Step Selection Input 0) Signal Allocation.	page 6-3																																										

Continued on next page.

Continued from previous page.

Parameter No.	Size	Name	Setting Range	Setting Unit	Default Setting	Applicable Motors	When Enabled	Classification	Reference	
Pn632	2	Input Signal Selections 12	0000 to FFFF	–	5438	All	After restart	Setup	–	
			/SEL4 (Program Step Selection Input 4) Signal Allocation							Reference
	n.□□□X		0	Active when CN1-40 input signal is ON (closed).						page 6-3
			1	Active when CN1-41 input signal is ON (closed).						
			2	Active when CN1-42 input signal is ON (closed).						
			3	Active when CN1-43 input signal is ON (closed).						
			4	Active when CN1-44 input signal is ON (closed).						
			5	Active when CN1-45 input signal is ON (closed).						
			6	Active when CN1-46 input signal is ON (closed).						
			7	The signal is always active.						
			8	The signal is always inactive.						
			9	Active when CN1-40 input signal is OFF (open).						
			A	Active when CN1-41 input signal is OFF (open).						
			B	Active when CN1-42 input signal is OFF (open).						
			C	Active when CN1-43 input signal is OFF (open).						
			D	Active when CN1-44 input signal is OFF (open).						
			E	Active when CN1-45 input signal is OFF (open).						
			F	Active when CN1-46 input signal is OFF (open).						
			/JOGP (Forward Jog Input) Signal Allocation							Reference
	n.□□X□		0 to F	The settings are the same as for /SEL4 (Program Step Selection Input 4) Signal Allocation.						page 6-3
		/JOGN (Reverse Jog Input) Signal Allocation							Reference	
n.□X□□		0 to F	The settings are the same as for /SEL4 (Program Step Selection Input 4) Signal Allocation.						page 6-3	
		/JOG0 (Jog Speed Table Selection Input 0) Signal Allocation							Reference	
n.X□□□		0 to F	The settings are the same as for /SEL4 (Program Step Selection Input 4) Signal Allocation.						page 6-3	

Continued on next page.

9.2 List of Parameters

9.2.2 List of Parameters

Continued from previous page.

Parameter No.	Size	Name	Setting Range	Setting Unit	Default Setting	Applicable Motors	When Enabled	Classification	Reference		
Pn633	2	Input Signal Selections 13	0000 to FFFF	–	8888	All	After restart	Setup	–		
			/JOG1 (Jog Speed Table Selection Input 1) Signal Allocation							Reference	
	n.□□□X		0	Active when CN1-40 input signal is ON (closed).							page 6-3
			1	Active when CN1-41 input signal is ON (closed).							
			2	Active when CN1-42 input signal is ON (closed).							
			3	Active when CN1-43 input signal is ON (closed).							
			4	Active when CN1-44 input signal is ON (closed).							
			5	Active when CN1-45 input signal is ON (closed).							
			6	Active when CN1-46 input signal is ON (closed).							
			7	The signal is always active.							
			8	The signal is always inactive.							
			9	Active when CN1-40 input signal is OFF (open).							
			A	Active when CN1-41 input signal is OFF (open).							
			B	Active when CN1-42 input signal is OFF (open).							
			C	Active when CN1-43 input signal is OFF (open).							
			D	Active when CN1-44 input signal is OFF (open).							
			E	Active when CN1-45 input signal is OFF (open).							
		F	Active when CN1-46 input signal is OFF (open).								
		/JOG2 (Jog Speed Table Selection Input 2) Signal Allocation							Reference		
n.□□X□		0 to F	The settings are the same as for /JOG1 (Jog Speed Table Selection Input 1) Signal Allocation.							page 6-3	
n.□X□□		Reserved parameter (Do not change.)									
n.X□□□		Reserved parameter (Do not change.)									
Pn634	2	Input Signal Selections 14	0000 to 0013	–	0002	All	After restart	Setup	–		
			SI8 Signal Selection							Reference	
	n.□□□X		0	Do not allocate an input signal to CN1-14 and CN1-15.							page 6-5
			1	Allocate the CLR signal as the input signal to CN1-14 and CN1-15.							
			2	Allocate the /DEC signal as the input signal to CN1-14 and CN1-15.							
			3	Allocate the /RGRT signal as the input signal to CN1-14 and CN1-15.							
			SI8 Signal Selection Logic							Reference	
	n.□□X□		0	Active when CN1-14 and Cn1-15 input signal is ON (closed).							page 6-5
			1	Active when CN1-14 and NC1-15 input signal is OFF (open).							
	n.□X□□		Reserved parameter (Do not change.)								
n.X□□□		Reserved parameter (Do not change.)									

Continued on next page.

Continued from previous page.

Parameter No.	Size	Name	Setting Range	Setting Unit	Default Setting	Applicable Motors	When Enabled	Classification	Reference	
Pn635	2	Output Signal Selections 10	0000 to 6666	–	0654	All	After restart	Setup	–	
	n.□□□X	/POUT0 (Programmable Output 0) Signal Allocation							Reference	
		0	Disabled (the above signal output is not used).							page 6-5
		1	Output the signal from the CN1-25 or CN1-26 output terminal.							
		2	Output the signal from the CN1-27 or CN1-28 output terminal.							
		3	Output the signal from the CN1-29 or CN1-30 output terminal.							
		4	Output the signal from the CN1-37 output terminal.							
		5	Output the signal from the CN1-38 output terminal.							
	6	Output the signal from the CN1-39 output terminal.								
	n.□□X□	/POUT1 (Programmable Output 1) Signal Allocation							Reference	
		0 to 6	The settings are the same as for /POUT0 (Programmable Output 0) Signal Allocation.							page 6-5
	n.□X□□	/POUT2 (Programmable Output 2) Signal Allocation							Reference	
		0 to 6	The settings are the same as for /POUT0 (Programmable Output 0) Signal Allocation.							page 6-5
	n.X□□□	/POUT3 (Programmable Output 3) Signal Allocation							Reference	
		0 to 6	The settings are the same as for /POUT0 (Programmable Output 0) Signal Allocation.							page 6-5
	Pn636	2	Output Signal Selections 11	0000 to 0666	–	0000	All	After restart	Setup	–
n.□□□X		/POUT4 (Programmable Output 4) Signal Allocation							Reference	
		0	Disabled (the above signal output is not used).							page 6-5
		1	Output the signal from the CN1-25 or CN1-26 output terminal.							
		2	Output the signal from the CN1-27 or CN1-28 output terminal.							
		3	Output the signal from the CN1-29 or CN1-30 output terminal.							
		4	Output the signal from the CN1-37 output terminal.							
5		Output the signal from the CN1-38 output terminal.								
n.□□X□		/POSRDY (Homing Completed Output) Signal Allocation							Reference	
		0 to 6	The settings are the same as for /POUT4 (Programmable Output 4) Signal Allocation.							page 6-5
n.□X□□	/DEN (Positioning Reference Distribution Output) Signal Allocation							Reference		
	0 to 6	The settings are the same as for /POUT4 (Programmable Output 4) Signal Allocation.							page 6-5	
n.X□□□	Reserved parameter (Do not change.)									

Continued on next page.

9.2 List of Parameters

9.2.2 List of Parameters

Continued from previous page.

Parameter No.	Size	Name	Setting Range	Setting Unit	Default Setting	Applicable Motors	When Enabled	Classification	Reference												
Pn637	2	Moving Mode	0000 to 0003	–	0000	All	After restart	Setup	–												
			<table border="1"> <thead> <tr> <th colspan="2">Moving Mode</th> <th>Reference</th> </tr> </thead> <tbody> <tr> <td rowspan="4">n.□□□X</td> <td>0</td> <td>Use linear coordinates.</td> <td rowspan="4">page 6-8</td> </tr> <tr> <td>1</td> <td>Use rotational coordinates. Use the shortest path.</td> </tr> <tr> <td>2</td> <td>Use rotational coordinates. Always move forward.</td> </tr> <tr> <td>3</td> <td>Use rotational coordinates. Always move in reverse.</td> </tr> </tbody> </table>						Moving Mode		Reference	n.□□□X	0	Use linear coordinates.	page 6-8	1	Use rotational coordinates. Use the shortest path.	2	Use rotational coordinates. Always move forward.	3	Use rotational coordinates. Always move in reverse.
	Moving Mode		Reference																		
	n.□□□X	0	Use linear coordinates.	page 6-8																	
		1	Use rotational coordinates. Use the shortest path.																		
		2	Use rotational coordinates. Always move forward.																		
		3	Use rotational coordinates. Always move in reverse.																		
n.□□X□		Reserved parameter (Do not change.)																			
n.□X□□		Reserved parameter (Do not change.)																			
n.X□□□		Reserved parameter (Do not change.)																			
Pn638	4	Forward Software Limit (P-LS)/End Point of Rotational Coordinates	-536,870,911 to +536,870,911	Reference units	+536,870,911	All	After restart	Setup	page 6-8												
Pn63A	4	Reverse Software Limit (N-LS)/Starting Point of Rotational Coordinates	-536,870,911 to +536,870,911	Reference units	-536,870,911	All	After restart	Setup	page 6-8												
Pn63C	4	Origin Position/Absolute Encoder Offset	-1,073,741,823 to +1,073,741,823	Reference units	0	All	After restart	Setup	page 6-8												
Pn63E	4	Acceleration Rate	1 to 199,999,999	1,000 (reference units /min ⁻¹) /ms	1000	All	Immediately	Setup	page 6-10												
Pn640	4	Deceleration Rate	1 to 199,999,999	1,000 (reference units /min ⁻¹) /ms	1000	All	Immediately	Setup	page 6-10												
Pn642	2	Homing Method	0000 to 0003	–	0000	All	After restart	–	–												
			<table border="1"> <thead> <tr> <th colspan="2">Homing Method</th> <th>Reference</th> </tr> </thead> <tbody> <tr> <td rowspan="4">n.□□□X</td> <td>0</td> <td>Homing is not executed.</td> <td rowspan="4">page 7-5</td> </tr> <tr> <td>1</td> <td>Use the /DEC signal and phase C for homing.</td> </tr> <tr> <td>2</td> <td>Use the /DEC signal for homing.</td> </tr> <tr> <td>3</td> <td>Use phase C for homing.</td> </tr> </tbody> </table>						Homing Method		Reference	n.□□□X	0	Homing is not executed.	page 7-5	1	Use the /DEC signal and phase C for homing.	2	Use the /DEC signal for homing.	3	Use phase C for homing.
	Homing Method		Reference																		
	n.□□□X	0	Homing is not executed.	page 7-5																	
		1	Use the /DEC signal and phase C for homing.																		
		2	Use the /DEC signal for homing.																		
		3	Use phase C for homing.																		
n.□□X□		Reserved parameter (Do not change.)																			
n.□X□□		Reserved parameter (Do not change.)																			
n.X□□□		Reserved parameter (Do not change.)																			

Continued on next page.

Continued from previous page.

Parameter No.	Size	Name	Setting Range	Setting Unit	Default Setting	Applicable Motors	When Enabled	Classification	Reference	
Pn643	2	Homing Direction	0000 to 0001	–	0000	All	Immediately	–	–	
	n.□□□X	Homing Direction							Reference	
		0	When the /HOME signal turns ON, homing is performed in the forward direction.							page 7-5
		1	When the /HOME signal turns ON, homing is performed in the reverse direction.							
	n.□□X□	Reserved parameter (Do not change.)								
	n.□X□□	Reserved parameter (Do not change.)								
n.X□□□	Reserved parameter (Do not change.)									
Pn644	4	Homing Movement Speed	1 to 199,999,999	1,000 reference units/min ⁻¹	1000	All	Immediately	Setup	page 7-5	
Pn646	4	Origin Approach Speed	1 to 199,999,999	1,000 reference units/min ⁻¹	1000	All	Immediately	Setup	page 7-5	
Pn648	4	Homing Creep Speed	1 to 199,999,999	1,000 reference units/min ⁻¹	1000	All	Immediately	Setup	page 7-6	
Pn64A	4	Homing Final Travel Distance	-1,073,741,823 to +1,073,741,823	Reference units	0	All	Immediately	Setup	page 7-6	
Pn64C	2	ZONE Signal Setting	0000 to 0001	–	0000	All	After restart	Setup	–	
	n.□□□X	ZONE Signal Setting							Reference	
		0	When the control power supply is turned ON or the SERVOPACK is reset, the /POUT0 to /POUT2 signals are inactive.							page 7-54
		1	When the control power supply is turned ON or the SERVOPACK is reset, the /POUT0 to /POUT2 signals are used as ZONE signals.							
	n.□□X□	Reserved parameter (Do not change.)								
	n.□X□□	Reserved parameter (Do not change.)								
n.X□□□	Reserved parameter (Do not change.)									
Pn64D	2	Reserved parameter (Do not change.)	–	–	0000	–	–	–	–	

*1. Refer to the following manual for details.

📖 Σ -7-Series Σ -7S SERVOPACK with Analog Voltage/Pulse Train References Product Manual (Manual No.: SIEP S800001 26)

*2. Set a percentage of the rated motor torque.

*3. These parameters are for SERVOPACKs with a Safety Module. Refer to the following manual for details.

📖 Σ -V-Series/ Σ -V-Series for Large-Capacity Models/ Σ -7-Series User's Manual Safety Module (Manual No.: SIEP C720829 06)

*4. Normally set this parameter to 0. If you use an External Regenerative Resistor, set the capacity (W) of the External Regenerative Resistor.

*5. The upper limit is the maximum output capacity (W) of the SERVOPACK.

*6. These parameters are for SERVOPACKs with the Dynamic Brake Option. Refer to the following manual for details.

📖 Σ -7-Series AC Servo Drive Σ -7S/ Σ -7W SERVOPACK with Dynamic Brake Hardware Option Specifications Product Manual (Manual No.: SIEP S800001 73)

Appendices

10

The appendix provides information on compatibility between SERVOPACK functions and SigmaWin+ functions, Digital Operator procedures, and a table of corresponding parameter numbers.

10.1 Corresponding SERVOPACK and SigmaWin+ Function Names .. 10-2

- 10.1.1 Corresponding SERVOPACK Utility Function Names 10-2
- 10.1.2 Corresponding SERVOPACK Monitor Display Function Names 10-3

10.2 Operation of Digital Operator 10-6

- 10.2.1 Overview 10-6
- 10.2.2 Operation of Utility Functions 10-7

10.1 Corresponding SERVOPACK and SigmaWin+ Function Names

This section gives the names and numbers of the utility functions and monitor display functions used by the SERVOPACKs and the names used by the SigmaWin+.

10.1.1 Corresponding SERVOPACK Utility Function Names

SigmaWin+		SERVOPACK	
Menu Bar Button	Function Name	Fn No.	Function Name
Setup	Origin Search	Fn003	Origin Search
	Absolute Encoder Reset	Fn008	Reset Absolute Encoder
	Adjust the Speed and Torque Reference Offset	Fn009	Autotune Analog (Speed/Torque) Reference Offset
		Fn00A	Manually Adjust Speed Reference Offset
		Fn00B	Manually Adjust Torque Reference Offset
	Adjust the Analog Monitor Output	Fn00C	Adjust Analog Monitor Output Offset
		Fn00D	Adjust Analog Monitor Output Gain
	Adjust the Motor Current Detection Signal Offsets	Fn00E	Autotune Motor Current Detection Signal Offset
		Fn00F	Manually Adjust Motor Current Detection Signal Offset
	Multiturn Limit Setting	Fn013	Multiturn Limit Setting after Multiturn Limit Disagreement Alarm
	Reset Option Module Configuration Error	Fn014	Reset Option Module Configuration Error
	Initialize Vibration Detection Level	Fn01B	Initialize Vibration Detection Level
	Set Origin	Fn020	Set Absolute Linear Encoder Origin
	Software Reset	Fn030	Software Reset
	Polarity Detection	Fn080	Polarity Detection
Tuning-less Level Setting	Fn200	Tuning-less Level Setting	
EasyFFT	Fn206	EasyFFT	
–	Fn066	Set Absolute Encoder Origin	
Parameters	Initialize	Fn005	Initializing Parameters
	Write Prohibition Setting	Fn010	Write Prohibition Setting
	Setup Wizard	–	–
Tuning	Autotuning without Host Reference	Fn201	Advanced Autotuning without Reference
	Autotuning with Host Reference	Fn202	Advanced Autotuning with Reference
	Custom Tuning	Fn203	One-Parameter Tuning
	Adjust Anti-resonance Control	Fn204	Adjust Anti-resonance Control
	Vibration Suppression	Fn205	Vibration Suppression
Moment of Inertia Estimation	–	–	
Monitoring	Product Information	Fn011	Display Servomotor Model
		Fn012	Display Software Version
		Fn01E	Display SERVOPACK and Servomotor IDs
		Fn01F	Display Servomotor ID from Feedback Option Module
Test Operation	Jog	Fn002	Jog
	Jog Program	Fn004	Jog Program

Continued on next page.

Continued from previous page.

SigmaWin+		SERVOPACK	
Menu Bar Button	Function Name	Fn No.	Function Name
Alarms	Alarm Display	Fn000	Display Alarm History
		Fn006	Clear Alarm History
	Reset Motor Type Alarm	Fn021	Reset Motor Type Alarm
Solutions	Mechanical Analysis	–	–
Table Editing	Edit Program Table	Fn060	Edit/Save Program Table
		Fn063	Initialize Program Table
	Edit ZONE Table	Fn061	Edit/Save ZONE Table
		Fn064	Initialize ZONE Table
	Edit Jog Speed Table	Fn062	Edit/Save Jog Speed Table
		Fn065	Initialize Jog Speed Table

10.1.2 Corresponding SERVOPACK Monitor Display Function Names

SigmaWin+		SERVOPACK	
Menu Bar Button	Name [Unit]	Un No.	Name [Unit]
Motion Monitor	Motor Speed [min^{-1}]	Un000	Motor Speed [min^{-1}]
	Speed Reference [min^{-1}]	Un001	Speed Reference [min^{-1}]
	Torque Reference [%]	Un002	Torque Reference [%] (percentage of rated torque)
	<ul style="list-style-type: none"> Rotary Servomotors: Rotational Angle 1 [encoder pulses] (number of encoder pulses from origin within one encoder rotation) Linear Servomotors: Electrical Angle 1 [linear encoder pulses] (linear encoder pulses from the polarity origin) 	Un003	<ul style="list-style-type: none"> Rotary Servomotors: Rotational Angle 1 [encoder pulses] (number of encoder pulses from origin within one encoder rotation displayed in decimal) Linear Servomotors: Electrical Angle 1 [linear encoder pulses] (linear encoder pulses from the polarity origin displayed in decimal)
	<ul style="list-style-type: none"> Rotary Servomotors: Rotational Angle 2 [deg] (electrical angle from origin within one encoder rotation) Linear Servomotors: Electrical Angle 2 [deg] (electrical angle from polarity origin) 	Un004	<ul style="list-style-type: none"> Rotary Servomotors: Rotational Angle 2 [deg] (electrical angle from polarity origin) Linear Servomotors: Electrical Angle 2 [deg] (electrical angle from polarity origin)
	Input Reference Pulse Speed [min^{-1}]	Un007	Input Reference Pulse Speed [min^{-1}] (displayed only during position control)
	Position Deviation [reference units]	Un008	Position Error Amount [reference units] (displayed only during position control)
	Accumulated Load Ratio [%]	Un009	Accumulated Load Ratio [%] (percentage of rated torque: effective torque in cycles of 10 seconds)
	Regenerative Load Ratio [%]	Un00A	Regenerative Load Ratio [%] (percentage of processable regenerative power: regenerative power consumption in cycles of 10 seconds)
	Dynamic Brake Resistor Power Consumption [%]	Un00B	Power Consumed by DB Resistance [%] (percentage of processable power at DB activation: displayed in cycles of 10 seconds)

Continued on next page.

10.1 Corresponding SERVOPACK and SigmaWin+ Function Names

10.1.2 Corresponding SERVOPACK Monitor Display Function Names

Continued from previous page.

SigmaWin+		SERVOPACK	
Menu Bar Button	Name [Unit]	Un No.	Name [Unit]
Motion Monitor	Input Reference Pulse Counter [reference units]	Un00C	Input Reference Pulse Counter [reference units]
	Feedback Pulse Counter [encoder pulses]	Un00D	Feedback Pulse Counter [encoder pulses]
	Fully-closed Loop Feedback Pulse Counter [external encoder resolution]	Un00E	Fully-closed Loop Feedback Pulse Counter [external encoder resolution]
	Upper Limit Setting of Motor Maximum Speed/Upper Limit Setting of Encoder Output Resolution	Un010*1	Upper Limit Setting of Motor Maximum Speed/Upper Limit Setting of Encoder Output Resolution
	Total Operation Time [100 ms]	Un012	Total Operation Time [100 ms]
	Feedback Pulse Counter [reference units]	Un013	Feedback Pulse Counter [reference units]
	Current Backlash Compensation Value [0.1 reference units]	Un030	Current Backlash Compensation Value [0.1 reference units]
	Backlash Compensation Value Setting Limit [0.1 reference units]	Un031	Backlash Compensation Value Setting Limit [0.1 reference units]
	Power Consumption [W]	Un032	Power Consumption [W]
	Consumed Power [0.001 Wh]	Un033	Consumed Power [0.001 Wh]
	Cumulative Power Consumption [Wh]	Un034	Cumulative Power Consumption [Wh]
	Absolute Encoder Multiturn Data	Un040	Absolute Encoder Multiturn Data
	Position within One Rotation of Absolute Encoder [encoder pulses]	Un041	Position within One Rotation of Absolute Encoder [encoder pulses]
	Lower Bits of Absolute Encoder Position [encoder pulses]	Un042	Lower Bits of Absolute Encoder Position [encoder pulses]
	Upper Bits of Absolute Encoder Position [encoder pulses]	Un043	Upper Bits of Absolute Encoder Position [encoder pulses]
	Error Monitor	Un090	Error Monitor (The last INDEXER error information that was generated.)
	Current issue position	Un045	Position Reference Current Position [reference units]
	Current motor position	Un046	Motor Current Position [reference units]
	Target position	Un049	Positioning Target Position [reference units]
	Target distance	Un04A	Positioning Distance [reference units]
	Registration target position	Un04B	Registration Target Position [reference units]
	Registration target distance	Un04C	Registration Distance [reference units]
	Program step	Un092	Program Step (This parameter gives the program step that is currently being executed. When programmed operation is not in progress, -1 is given.)
Program event lapse time	Un093	Elapsed Event Time [ms] (This parameter gives the time that has elapsed since the program event was detected. When programmed operation is not in progress, 0 is given.)	
Program loop pass through time	Un094	Loop Execution Elapsed Time [loops] (This parameter gives the number of loop executions for the program step that is currently being executed. When programmed operation is not in progress, 0 is given.)	

Continued on next page.

Continued from previous page.

SigmaWin+		SERVOPACK	
Menu Bar Button	Name [Unit]	Un No.	Name [Unit]
Status Monitor	Polarity Sensor Signal Monitor	Un011	Polarity Sensor Signal Monitor
	Active Gain Monitor	Un014	Effective Gain Monitor (gain settings 1 = 1, gain settings 2 = 2)
	Safety I/O Signal Monitor	Un015	Safety I/O Signal Monitor
Input Signal Monitor	Input Signal Monitor	Un005	Input Signal Monitor
Output Signal Monitor	Output Signal Monitor	Un006	Output Signal Monitor
Service Life Monitor	Installation Environment Monitor – SERVOPACK	Un025	SERVOPACK Installation Environment Monitor [%]
	Installation Environment Monitor – Servomotor*2	Un026*2	Servomotor Installation Environment Monitor [%]
	Service Life Prediction Monitor – Built-in Fan	Un027	Built-in Fan Remaining Life Ratio [%]
	Service Life Prediction Monitor – Capacitor	Un028	Capacitor Remaining Life Ratio [%]
	Service Life Prediction Monitor – Surge Prevention Circuit	Un029	Surge Prevention Circuit Remaining Life Ratio [%]
	Service Life Prediction Monitor – Dynamic Brake Circuit	Un02A	Dynamic Brake Circuit Remaining Life Ratio [%]
Product Information	Motor – Resolution	Un084	Linear Encoder Pitch (Scale pitch = $Un084 \times 10^{Un085}$ [pm])
		Un085	Linear Encoder Pitch Exponent (Scale pitch = $Un084 \times 10^{Un085}$ [pm])
–	–	Un020	Rated Motor Speed [min^{-1}]
	–	Un021	Maximum Motor Speed [min^{-1}]

*1. You can use Un010 to monitor the upper limit setting for the maximum motor speed or the upper limit setting for the encoder output resolution.
 You can monitor the upper limit of the encoder output resolution setting (Pn281) for the current maximum motor speed setting (Pn385), or you can monitor the upper limit of the maximum motor speed setting for the current encoder output resolution setting.
 Select which signal to monitor with Pn080 = n.X□□□ (Calculation Method for Maximum Speed or Divided Output Pulses).

- If Pn080 = n.0□□□, the encoder output resolution (Pn281) that can be set is displayed.
- If Pn080 = n.1□□□, the maximum motor speed (Pn385) that can be set is displayed in mm/s.

*2. This applies to the following motors. The display will show 0 for all other models.
 SGM7J, SGM7A, SGM7P, SGM7G, and SGMCV

10.2 Operation of Digital Operator

10.2.1 Overview

Connect the digital operator to the SERVOPACK, and turn ON the power to the SERVOPACK. The initial display appears, and then the Parameter/Monitoring Function screen appears. Press the  key to change the function.

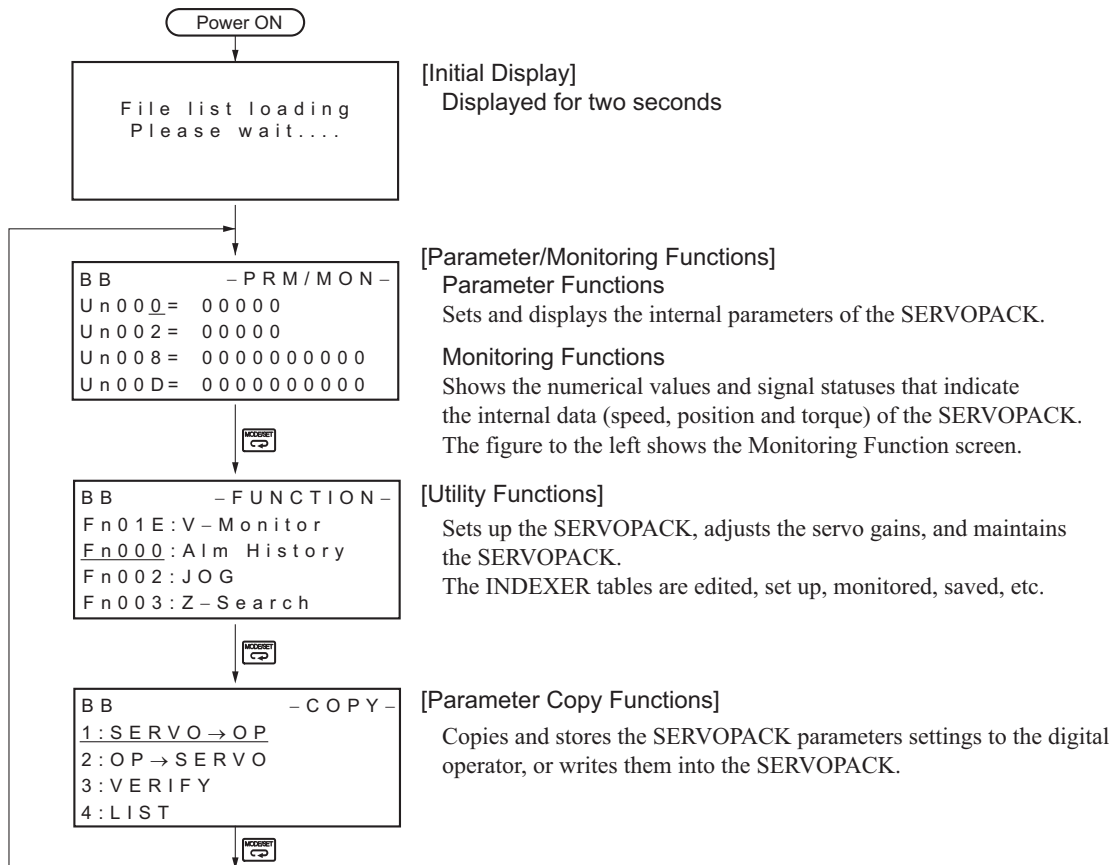

Reading the Screen

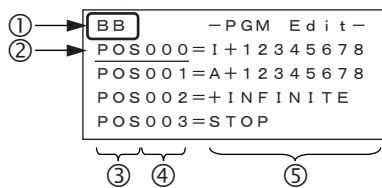

- The SERVOPACK status is always displayed at the top left of the screen (①).
 BB: Base blocked
 RUN: Servomotor is ON
 A.□□□ : Alarm/warning is in effect (□□□ is the alarm/warning code).
 PT NT: Forward run and reverse run prohibited (Overtravel)
 P-OT: Forward run prohibited (Overtravel)
 N-OT: Reverse run prohibited (Overtravel)
 P-LS: Forward software limit
 N-LS: Reverse software limit
 NO-OP: Setting disabled or setting error
 HBB: During hard wire base block
- The figure of editing screen used in the program tables, ZONE tables and JOG speed tables has the following elements.
 ② : The article and table number currently selected

③ : The article of the table

④ : The table number

⑤ : The table settings

Note: The line beneath POS000 shows that this indication is flashing. This line does not appear on the actual screen. Note also that the part that flashes is referred to as the cursor in this document.

10.2.2 Operation of Utility Functions

Utility Functions

The following table shows whether utility functions can be set or not with the digital operator.

Fn No.	Function	Possible/Not Possible	Remarks and Reference
Fn000	Alarm history display	○	
Fn002	JOG operation	○	
Fn003	Origin search	○	
Fn004	Program JOG operation	○	
Fn005	Initializing parameter settings	○	
Fn006	Clearing alarm history	○	
Fn008	Absolute encoder multiturn reset and encoder alarm reset	○	
Fn009	Autotune analog (speed/torque) reference offset	○	
Fn00A	Manually adjust speed reference offset	○	
Fn00B	Manually adjust torque reference offset	○	
Fn00C	Offset adjustment of analog monitor output	○	
Fn00D	Gain adjustment of analog monitor output	○	
Fn00E	Automatic offset-signal adjustment of motor current detection signal	○	
Fn00F	Manual offset-signal adjustment of motor current detection signal	○	
Fn010	Write prohibited setting	○	Σ-7-Series Servo Drive Digital Operator Operating Manual (Manual No.: SIEP S800001 33)
Fn011	Servomotor model display	○	
Fn012	SERVOPACK software version display	○	
Fn013	Multiturn limit value setting change when a multiturn limit disagreement alarm (A.CC0) occurs	○	
Fn014	Resetting configuration error in option module	○	
Fn01B	Vibration detection level initialization	○	
Fn01E	Display of SERVOPACK and servomotor ID	○	
Fn01F	Display of servomotor ID in feedback option module	○	
Fn020	Origin setting	○	
Fn030	Software reset	○	
Fn080	Polarity detection	○	
Fn200	Tuning-less levels setting	○	
Fn201	Advanced autotuning	○	
Fn202	Advanced autotuning by reference	○	
Fn203	One-parameter tuning	○	
Fn204	Anti-resonance control adjustment function	○	
Fn205	Vibration suppression function	○	
Fn206	EasyFFT	○	
Fn207	Online vibration monitor	○	

Continued on next page.

○: Possible ×: Not possible

Continued from previous page.

Fn No.	Function	Possible/Not Possible	Remarks and Reference
Fn060	Program table edit/save	○	Program Table Edit/Save (Fn060) on page 10-8
Fn061	ZONE table edit/save	○	ZONE Table Edit/Save (Fn061) on page 10-13
Fn062	JOG speed table edit/save	○	JOG Speed Table Edit/Save (Fn062) on page 10-15
Fn063	Program table initialization	○	Program Table Initialization (Fn063) on page 10-17
Fn064	ZONE table initialization	○	ZONE Table Initialization (Fn064) on page 10-18
Fn065	JOG speed table initialization	○	JOG Speed Table Initialization (Fn065) on page 10-19

○: Possible x: Not possible

Program Table Edit/Save (Fn060)

This function edits and saves program tables. Saving a program table to flash memory after editing it ensures that the data will be retained even after the control power has been turned OFF.

Codes Displayed on the Program Table Editing Screen

Refer to the following section for information on interpreting the displays.

Reading the Screen on page 10-6

PGM STEP	POS	SPD	RDST	RSPD	ACC	DEC	POUT	EVENT	LOOP	NEXT
0	POS000	SPD000	RDST000	RSPD000	ACC000	DEC000	POUT000	EVT000	LOOP000	NEXT000
1	POS001	SPD001	RDST001	RSPD001	ACC001	DEC001	POUT001	EVT001	LOOP001	NEXT001
⋮	⋮	⋮	⋮	⋮	⋮	⋮	⋮	⋮	⋮	⋮
31	POS31	SPD31	RDST31	RSPD31	ACC31	DEC31	POUT31	EVT31	LOOP31	NEXT31

◆ Preparation

The following conditions must be met to edit and save program tables.

- The write-prohibited setting (Fn010) must not be set to write-protect parameters.
- The program must not be running or on hold.
- A program table save operation must not be in progress for any means other than the digital operator.

◆ Editing Program Table

The operating procedure when setting the acceleration (ACC) in program step 5 is explained here.

Step	Display after Operation	Keys	Operation
1	<pre> BB -FUNCTION- Fn207 V-Monitor Fn060 PGM Edit Fn061 ZONE Edit Fn062 JSPD Edit </pre>	 	Press the key to open the Utility Function Mode main menu, and move the cursor with the keys to select Fn060.
2	<pre> BB -PGM Edit- POS000=STOP POS001=STOP POS002=STOP POS003=STOP </pre>		Press the key to view the Fn060 operation screen.

Continued on next page.

Continued from previous page.

Step	Display after Operation	Keys	Operation
3	<pre>BB -PGM Edit- ACC002=: ACC003=: ACC004=: ACC005=:</pre>	<div style="display: flex; flex-direction: column; align-items: center;"> <div style="display: flex; gap: 10px;"> < > </div> <div style="display: flex; gap: 10px;"> ▲ ▼ </div> <div style="display: flex; gap: 10px;"> SCROLL ▲ </div> <div style="display: flex; gap: 10px;"> SCROLL ▼ </div> </div>	<p>Move the cursor using the <> keys and ▲▼ keys (or the SCROLL + ▲ and SCROLL + ▼ keys) to select the article and program step of the program table to be edited. Refer to the following section for details on the methods to move the cursor.</p> <p> ■ Method for Moving the Cursor on page 10-9</p>
4	<pre>BB -PGM Edit- ACC002=: ACC003=: ACC004=: ACC005=:</pre>	<div style="border: 1px solid black; padding: 5px; display: inline-block;">DATA</div>	<p>Press the DATA key to move the cursor to the setting side of the table.</p>
5	<pre>BB -PGM Edit- ACC002=: ACC003=: ACC004=: ACC005=0000_1000</pre>	<div style="display: flex; flex-direction: column; align-items: center;"> <div style="display: flex; gap: 10px;"> < > </div> <div style="display: flex; gap: 10px;"> ▲ ▼ </div> </div>	<p>Move the cursor with the <> keys, and change the table settings with the ▲▼ keys.* Refer to the following section for detailed setting methods for each item.</p> <p> ◆ Details on How to Set Table Settings on page 10-10</p>
6	<pre>BB -PGM Edit- ACC002=: ACC003=: ACC004=: ACC005=00001000</pre>	<div style="border: 1px solid black; padding: 5px; display: inline-block;">DATA</div>	<p>Press the DATA key to enter the setting. The cursor returns to the program table article and program step side.</p>
7	<p>Repeat steps 3 to 6 to set the program table. On completing the setting of all the program tables to be used, save the program tables to flash memory by following the procedure in Saving Program Tables.</p>		

* If setting is attempted in an operation prohibited state, it will not be possible to change the setting. In this case, make the setting again by referring to Preparation.

■ Method for Moving the Cursor

The values within the frames in the figure below are the articles and steps of the program table displayed at the digital operator.

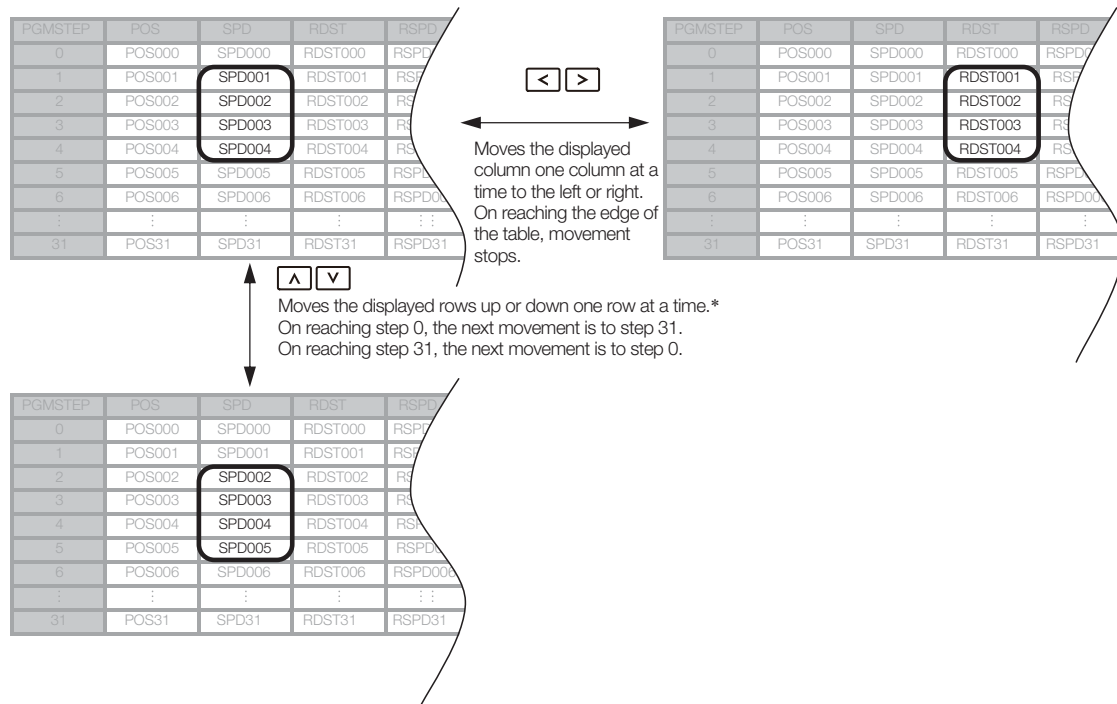

* You can move 4 rows at a time by holding down the ▲ or ▼ key. By using the SCROLL key at the same time as these keys, you can move 30 rows at a time.

◆ Details on How to Set Table Settings

Details on the setting method for step 5 in *Editing Program Table* on page 10-8 are shown below.

■ POS: Target Position

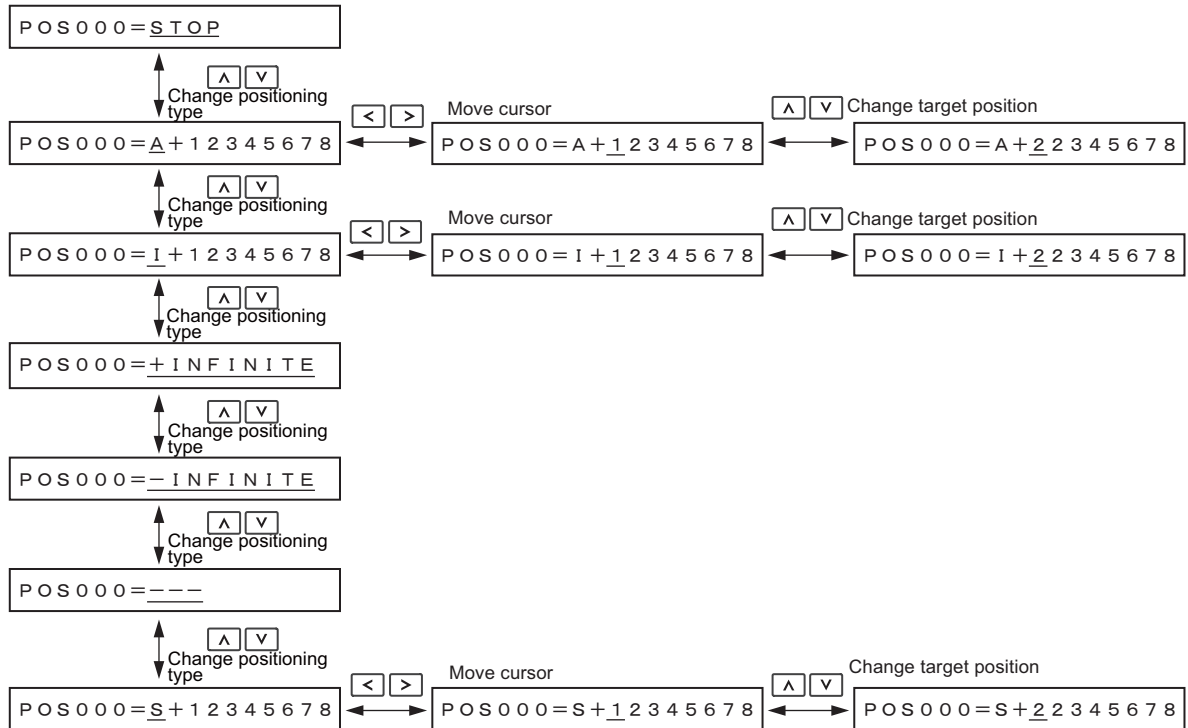

Note: Refer to the following section for details on positioning types and target positions.

☞ 7.3.4 Settings in the Program Table on page 7-13

■ SPD: Positioning Speed

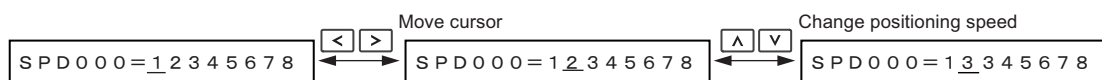

Note: Refer to the following section for details on the positioning speed.

☞ 7.3.4 Settings in the Program Table on page 7-13

■ RDST: Registration Distance

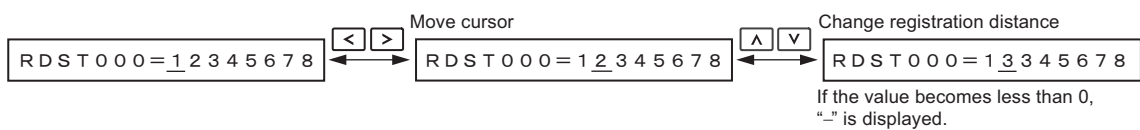

Note: Refer to the following section for details on the registration distance.

☞ 7.3.4 Settings in the Program Table on page 7-13

■ RSPD: Registration Speed

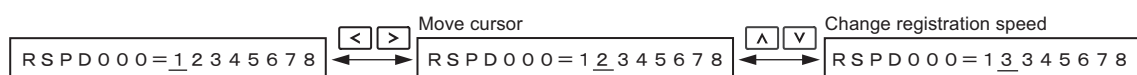

Note: Refer to the following section for details on the registration speed.

☞ 7.3.4 Settings in the Program Table on page 7-13

■ ACC: Acceleration

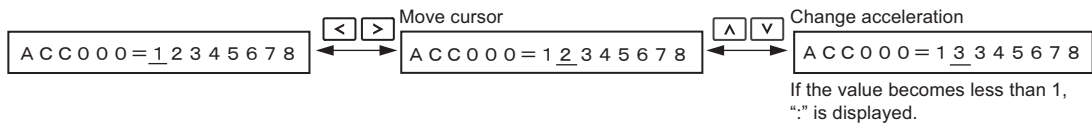

Note: Refer to the following section for details on the acceleration rate.

☞ 7.3.4 Settings in the Program Table on page 7-13

■ DEC: Deceleration

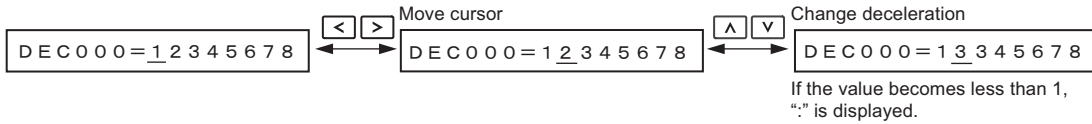

Note: Refer to the following section for details on the deceleration rate.

☞ 7.3.4 Settings in the Program Table on page 7-13

■ POUT: Programmable Output Signals

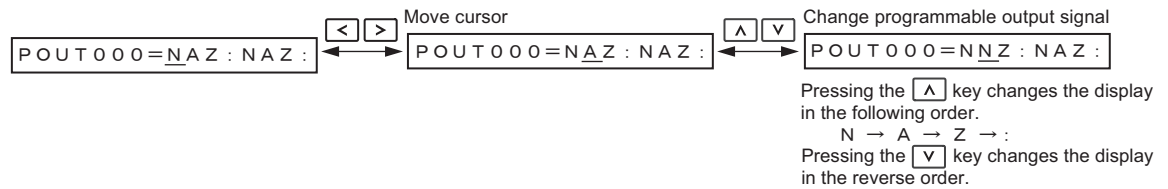

Note: Refer to the following section for details on the programmable output signals.

☞ 7.3.4 Settings in the Program Table on page 7-13

■ EVENT: Pass Condition

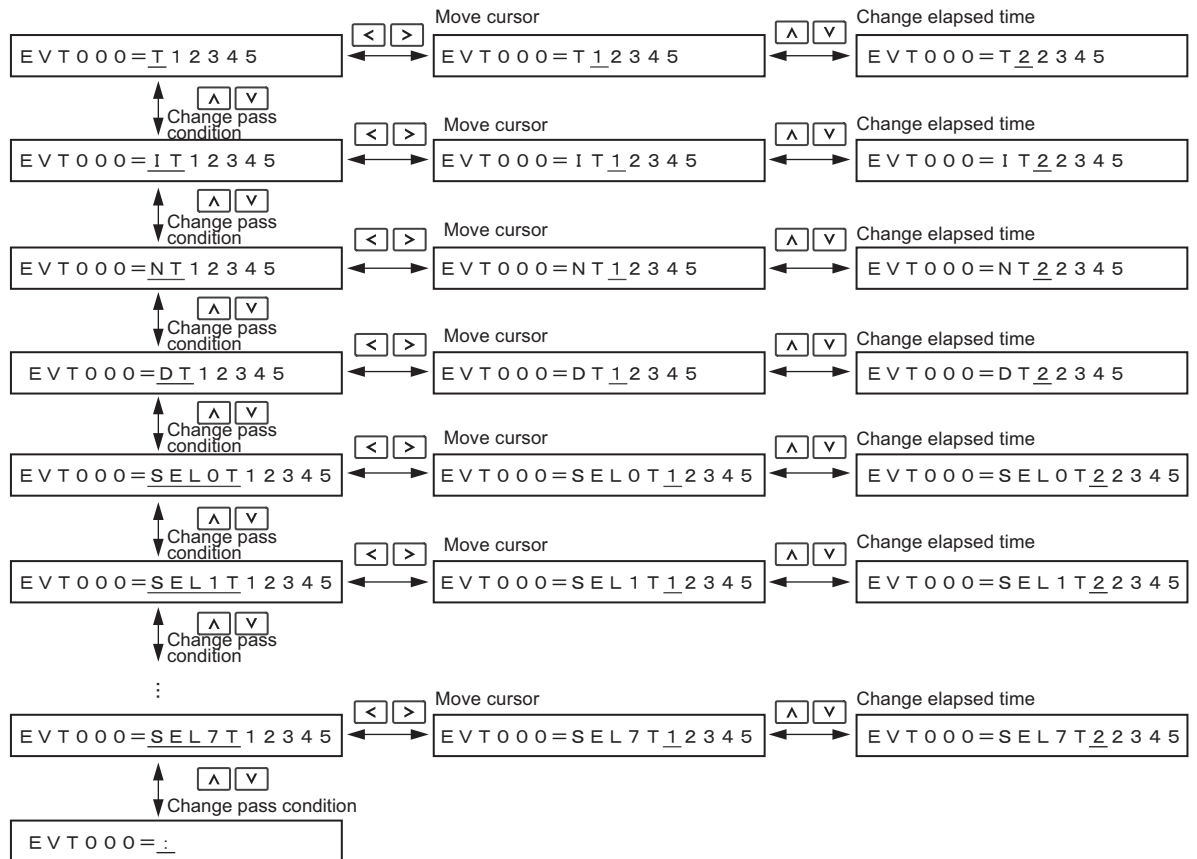

Note: 1. Refer to the following section for details on the pass condition and elapsed time.

☞ 7.3.4 Settings in the Program Table on page 7-13

2. The default setting is EVT000 = IT00000.

■ LOOP: Number of Executions

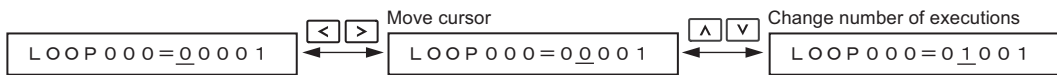

Note: Refer to the following section for details on the number of executions.
 7.3.4 Settings in the Program Table on page 7-13

■ NEXT: PGMSTEP to be Executed Next

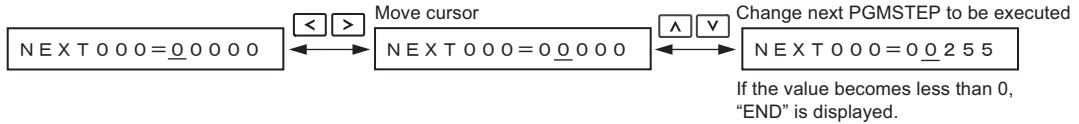

Note: Refer to the following section for details on the program step to execute next.
 7.3.4 Settings in the Program Table on page 7-13

◆ Saving Program Tables

The operating procedure for saving program tables is shown below.

Step	Display after Operation	Keys	Operation
1	<pre> BB -PGM Edit- POS000=STOP POS001=STOP POS002=STOP POS003=STOP </pre>	-	Display the program table editing screen.
2	<pre> BB -PGM Edit- STORE PGM TABLE? CANCEL STORE </pre>		Press the key to view the program table save operation screen.
3	<pre> BB -PGM Edit- STORE PGM TABLE? CANCEL STORE </pre>		Move the cursor with the keys to select "STORE". Note: Selecting "CANCEL" and pressing the key will return the display to the program table editing screen.
4	<pre> BB -PGM Edit- Storing now... Please wait. </pre>		Press the key to start saving the program table to flash memory.* Do not turn OFF the control power supply until saving has been completed normally.
5	<pre> BB -PGM Edit- POS000=STOP POS001=STOP POS002=STOP POS003=STOP </pre>	-	When saving to flash memory has been completed normally, the display returns to the program table editing screen.
6	<pre> BB -FUNCTION- Fn207 V-Monitor Fn060 PGM Edit Fn061 ZONE Edit Fn062 JSPD Edit </pre>		Press the key to return to the Utility Function Mode main menu.

* If the key is pressed in an operation prohibited state, "Error." is displayed for approximately 2 seconds and then the display returns to the program table editing screen. In this case, make the setting again by referring to ◆ Preparation.

ZONE Table Edit/Save (Fn061)

This function edits and saves ZONE tables. Saving a ZONE table to flash memory after editing it ensures that the data will be retained even after the control power has been turned OFF.

■ Codes Displayed on the ZONE Table Editing Screen

For details on how to read the screen, refer to *Reading the Screen* on page 10-6.

ZONE Number	ZONE P	ZONE N
0	ZP000	ZN000
1	ZP001	ZN001
⋮	⋮	⋮
8	ZP008	ZN008































◆ Preparation

The following conditions must be met to edit and save ZONE tables.

- The write-prohibited setting (Fn010) must not be set to write-protect parameters.
- A ZONE table save operation must not be in progress for any means other than the digital operator.

◆ Editing ZONE Tables

The operating procedure when setting ZONE N in ZONE number 5 is explained here.

Step	Display after Operation	Keys	Operation
1	<pre>BB -FUNCTION- Fn060 PGM Edit Fn061 ZONE Edit Fn062 JSPD Edit Fn063 PGM Init</pre>	  	Press the  key to open the Utility Function Mode main menu, and move the cursor with the   keys to select Fn061.
2	<pre>BB -ZONE Edit- ZP000=+000000000 ZP001=+000000000 ZP002=+000000000 ZP003=+000000000</pre>		Press the  key to view the Fn061 operation screen.
3	<pre>BB -ZONE Edit- ZN002=+000000000 ZN003=+000000000 ZN004=+000000000 ZN005=+000000000</pre>	   	Move the cursor using the   keys and   keys to select the ZONE table number to be edited. Refer to the following section for details on the methods to move the cursor.  ■ <i>Method for Moving the Cursor</i> on page 10-9
4	<pre>BB -ZONE Edit- ZN002=+000000000 ZN003=+000000000 ZN004=+000000000 ZN005=+000000000</pre>		Press the  key to move the cursor to the setting side of the table.
5	<pre>BB -ZONE Edit- ZN002=+000000000 ZN003=+000000000 ZN004=+000000000 ZN005=+12345678</pre>	   	Move the cursor using the   keys and change the ZONE boundary values using the   keys.*
6	<pre>BB -ZONE Edit- ZN002=+000000000 ZN003=+000000000 ZN004=+000000000 ZN005=+12345678</pre>		Press the  key to enter the setting. The cursor returns to the ZONE table number side.
7	Repeat steps 3 to 6 to set the ZONE table. On completing the setting of all the ZONE tables to be used, save the ZONE tables to flash memory by following the procedure in  <i>Saving ZONE Tables</i> .		

* If setting is attempted in an operation prohibited state, it will not be possible to change the setting. In this case, make the setting again by referring to  *Preparation*.

■ Method for Moving the Cursor

The values within the frames in the figure below are the ZONE table numbers displayed at the digital operator.

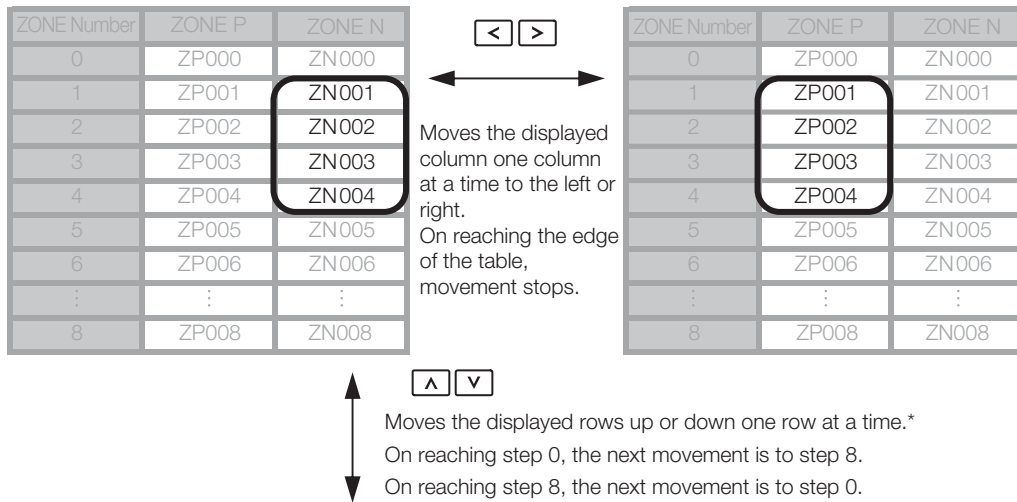

ZONE Number	ZONE P	ZONE N
0	ZP000	ZN000
1	ZP001	ZN001
2	ZP002	ZN002
3	ZP003	ZN003
4	ZP004	ZN004
5	ZP005	ZN005
6	ZP006	ZN006
⋮	⋮	⋮
8	ZP008	ZN008

* You can move 3 rows at a time by holding down the or key.



◆ Saving ZONE Tables



The operating procedure for saving ZONE tables is shown below.

Step	Display after Operation	Keys	Operation
1	<pre> BB -ZONE Edit- ZP000=+00000000 ZP001=+00000000 ZP002=+00000000 ZP003=+00000000 </pre>	-	Display the ZONE table editing screen.
2	<pre> BB -ZONE Edit- STORE ZONE TABLE? CANCEL STORE </pre>		Press the key to view the ZONE table save screen.
3	<pre> BB -ZONE Edit- STORE ZONE TABLE? CANCEL STORE </pre>		Move the cursor with the keys to select "STORE". Note: Selecting "CANCEL" and pressing the key will return the display to the ZONE table editing screen.
4	<pre> BB -ZONE Edit- Storing now... Please wait. </pre>		Press the key to start saving the ZONE table to flash memory.* Do not turn OFF the control power supply until saving has been completed normally.

Continued on next page.

Continued from previous page.

Step	Display after Operation	Keys	Operation
5	<pre>BB -ZONE Edit- ZP000=+00000000 ZP001=+00000000 ZP002=+00000000 ZP003=+00000000</pre>	-	When saving to flash memory has been completed normally, the display returns to the ZONE table editing screen.
6	<pre>BB -FUNCTION- Fn060 PGM Edit Fn061 ZONE Edit Fn062 JSPD Edit Fn063 PGM Init</pre>		Press the  key to return to the Utility Function Mode main menu.

* If the  key is pressed in an operation prohibited state, "Error." is displayed for approximately 2 seconds and then the display returns to the ZONE table editing screen. In this case, make the setting again by referring to  Preparation.

JOG Speed Table Edit/Save (Fn062)

This function edits and saves JOG speed tables. Saving a JOG speed table to flash memory after editing it ensures that the data will be retained even after the control power has been turned OFF.

Refer to the following section for information on interpreting the displays.

 Reading the Screen on page 10-6

























◆ Preparation

The following conditions must be met to save and edit JOG speed tables.

- The write-prohibited setting (Fn010) must not be set to write-protect parameters.
- A JOG speed table save operation must not be in progress for any means other than the digital operator.



◆ Editing JOG Speed Tables

The operating procedure when setting the value for JOG speed table number 5 is explained here.

Step	Display after Operation	Keys	Operation
1	<pre>BB -FUNCTION- Fn061 ZONE Edit Fn062 JSPD Edit Fn063 PGM Init Fn064 ZONE Init</pre>	  	Press the  key to open the Utility Function Mode main menu, and move the cursor with the   keys to select Fn062.
2	<pre>BB -JSPD Edit- JSPD000=00001000 JSPD001=00001000 JSPD002=00001000 JSPD003=00001000</pre>		Press the  key to view the Fn062 operation screen.
3	<pre>BB -JSPD Edit- JSPD002=00001000 JSPD003=00001000 JSPD004=00001000 JSPD005=00001000</pre>	 	Move the cursor using the   keys to select the JOG speed table number to be edited. Pressing the  key when the cursor is on JOG speed table number 0 moves it to number 15. Pressing the  key when the cursor is on JOG speed table number 15 moves it to number 0.
4	<pre>BB -JSPD Edit- JSPD002=00001000 JSPD003=00001000 JSPD004=00001000 JSPD005=00001000</pre>		Press the  key to move the cursor to the setting side of the table.
5	<pre>BB -JSPD Edit- JSPD002=00001000 JSPD003=00001000 JSPD004=00001000 JSPD005=12345678</pre>	   	Move the cursor with the   keys, and change the JOG speed setting with the   keys.*

Continued on next page.











Continued from previous page.

Step	Display after Operation	Keys	Operation
6	<pre>BB -JSPD Edit- JSPD002=00001000 JSPD003=00001000 JSPD004=00001000 JSPD005=12345678</pre>		Press the  key to enter the setting. The cursor returns to the JOG speed table number side.
7	Repeat steps 3 to 6 to set the JOG speed table. On completing the setting of all the JOG speed tables to be used, save the JOG speed tables to flash memory by following the procedure in ◆ Saving JOG Speed Tables .		

* If setting is attempted in an operation prohibited state, it will not be possible to change the setting. In this case, make the setting again by referring to **◆ Preparation**.

◆ Saving JOG Speed Tables

The operating procedure for saving JOG speed tables is shown below.

Step	Display after Operation	Keys	Operation
1	<pre>BB -JSPD Edit- JSPD000=00001000 JSPD001=00001000 JSPD002=00001000 JSPD003=00001000</pre>	-	Display the JOG speed table editing screen.
2	<pre>BB -JSPD Edit- STORE JSPD TABLE? CANCEL STORE</pre>		Press the  key to view the JOG speed table save screen.
3	<pre>BB -JSPD Edit- STORE JSPD TABLE? CANCEL STORE</pre>	 	Move the cursor with the   keys to select "STORE". Note: Selecting "CANCEL" and pressing the  key will return the display to the JOG speed table editing screen.
4	<pre>BB -JSPD Edit- Storing now... Please wait.</pre>		Press the  key to start saving the JOG speed table to flash memory.* Do not turn OFF the control power supply until saving has been completed normally.
5	<pre>BB -JSPD Edit- JSPD000=00001000 JSPD001=00001000 JSPD002=00001000 JSPD003=00001000</pre>	-	When saving to flash memory has been completed normally, the display returns to the JOG speed table editing screen.
6	<pre>BB -FUNCTION- Fn061 ZONE Edit Fn062 JSPD Edit Fn063 PGM Init Fn064 ZONE Init</pre>		Press the  key to return to the Utility Function Mode main menu.

* If the  key is pressed in an operation prohibited state, "Error." is displayed for approximately 2 seconds and then the display returns to the JOG speed table editing screen. In this case, make the setting again by referring to **◆ Preparation**.

Program Table Initialization (Fn063)















This function initializes the program tables and restores the default settings.



◆ Preparation

The following conditions must be met to initialize the program table.

- The write-prohibited setting (Fn010) must not be set to write-protect parameters.
- The program must not be running or on hold.
- A program table initialization must not be in progress for any means other than the digital operator.

◆ Operating Procedure

Step	Display after Operation	Keys	Operation
1	<pre>BB -FUNCTION- Fn062 JSPD Edit Fn063 PGM Init Fn064 ZONE Init Fn065 JSPD Init</pre>	  	Press the  key to open the Utility Function Mode main menu, and move the cursor with the   keys to select Fn063.
2	<pre>BB -PGM Init- Start : [DATA] Return : [SET]</pre>		Press the  key to view the Fn063 operation screen.
3	<pre>BB -PGM Init- Restoring now... Please wait.</pre>		Press the  key to start program table initialization.* Do not turn OFF the control power supply until initialization has been completed normally. To cancel the Fn063 operation, press the  key before pressing the  key. The display returns to the Utility Function Mode main menu without executing the operation.
4	<pre>BB -PGM Init- Done. Press [SET] key.</pre>	-	When program table initialization has been completed normally, "Done." is displayed.
5	<pre>BB -FUNCTION- Fn062 JSPD Edit Fn063 PGM Init Fn064 ZONE Init Fn065 JSPD Init</pre>		Press the  key to return to the Utility Function Mode main menu.

* If the  key is pressed in an operation prohibited state, "Error." is displayed for approximately 2 seconds and then the display returns to the Fn063 operation screen. In this case, make the setting again by referring to  Preparation.

ZONE Table Initialization (Fn064)















This function initializes ZONE tables and restores the default settings.

◆ Preparation

The following conditions must be met to initialize ZONE tables.

- The write-prohibited setting (Fn010) must not be set to write-protect parameters.
- A ZONE table initialization must not be in progress for any means other than the digital operator.

◆ Operating Procedure

Step	Display after Operation	Keys	Operation
1	<pre>BB -FUNCTION- Fn063 PGM Init Fn064 ZONE Init Fn065 JSPD Init</pre>	  	Press the  key to open the Utility Function Mode main menu, and move the cursor with the   keys to select Fn064.
2	<pre>BB -ZONE Init- Start : [DATA] Return: [SET]</pre>		Press the  key to view the Fn064 operation screen.
3	<pre>BB -ZONE Init- Restoring now... Please wait.</pre>		Press the  key to start ZONE table initialization.* Do not turn OFF the control power supply until initialization has been completed normally. To cancel the Fn064 operation, press the  key before pressing the  key. The display returns to the Utility Function Mode main menu without executing the operation.
4	<pre>BB -ZONE Init- Done. Press [SET] key.</pre>	—	When ZONE table initialization has been completed normally, "Done." is displayed.
5	<pre>BB -FUNCTION- Fn063 PGM Init Fn064 ZONE Init Fn065 JSPD Init</pre>		Press the  key to return to the Utility Function Mode main menu.

* If the  key is pressed in an operation prohibited state, "Error." is displayed for approximately 2 seconds and then the display returns to the Fn064 operation screen. In this case, make the setting again by referring to **◆ Preparation**.

JOG Speed Table Initialization (Fn065)















This function initializes JOG speed tables and restores the default settings.

◆ Preparation

The following conditions must be met to initialize JOG speed tables.

- The write-prohibited setting (Fn010) must not be set to write-protect parameters.
- A JOG speed table initialization must not be in progress for any means other than the digital operator.

◆ Operating Procedure

Step	Display after Operation	Keys	Operation
1	<pre>BB -FUNCTION- Fn064 ZONE Init Fn065 JSPD Init</pre>	  	Press the  key to open the Utility Function Mode main menu, and move the cursor with the   keys to select Fn065.
2	<pre>BB -JSPD Init- Start : [DATA] Return : [SET]</pre>		Press the  key to view the Fn065 operation screen.
3	<pre>BB -JSPD Init- Restoring now... Please wait.</pre>		Press the  key to start JOG speed table initialization.* Do not turn OFF the control power supply until initialization has been completed normally. To cancel the Fn065 operation, press the  key before pressing the  key. The display returns to the Utility Function Mode main menu without executing the operation.
4	<pre>BB -JSPD Init- Done. Press [SET] key.</pre>	-	When JOG speed table initialization has been completed normally, "Done." is displayed.
5	<pre>BB -FUNCTION- Fn064 ZONE Init Fn065 JSPD Init</pre>		Press the  key to return to the Utility Function Mode main menu.

* If the  key is pressed in an operation prohibited state, "Error." is displayed for approximately 2 seconds and then the display returns to the Fn065 operation screen. In this case, make the setting again by referring to **◆ Preparation**.

Index

A

absolute encoder
 offset - - - - - 6-12
 ACC - - - - - 7-13
 Acceleration Rate - - - - - 6-10
 alarms
 alarm reset possibility - - - - - 8-2
 INDEXER module alarm displays and
 troubleshooting - - - - - 8-36
 troubleshooting alarms - - - - - 8-8
 Average Position Reference Movement Time - - - - - 6-11

B

base block (BB) - - - - - x

C

CN1 - - - - - 3-4
 coefficient of speed fluctuation - - - - - 2-9
 consecutive stops - - - - - 7-39
 control method selection - - - - - 6-2
 cursor - - - - - 10-7

D

DEC - - - - - 7-13
 Deceleration Rate - - - - - 6-10
 Digital Operator - - - - - 10-6

E

EVENT - - - - - 7-13
 EVENT examples - - - - - 7-42

F

FG - - - - - 3-6

H

homing - - - - - 7-4
 approach speed - - - - - 7-5
 creep speed - - - - - 7-6
 final travel distance - - - - - 7-6
 movement speed - - - - - 7-5

I

I/O signals
 allocations - - - - - 6-3
 functions - - - - - 3-4
 monitoring - - - - - 5-4
 names - - - - - 3-4
 input signals
 allocations - - - - - 6-3

J

JOG speed table - - - - - 7-44
 editing JOG speed tables - - - - - 10-15
 jog speed selection - - - - - 7-45
 JOG speed table initialization - - - - - 10-19
 jog speeds - - - - - 7-44
 saving JOG speed tables - - - - - 10-16

L

Linear Servomotor - - - - - x
 Linear Servomotor Overheat Protection Input - - - - - 3-5
 list of alarms - - - - - 8-2
 list of parameters - - - - - 9-3
 LOOP - - - - - 7-13

M

Main Circuit Cable - - - - - x
 monitor
 monitor display function - - - - - 10-3
 Motion Monitor - - - - - 5-2

N

NEXT - - - - - 7-13

O

origin - - - - - 7-5

P

parameters
 notation (numeric settings) - - - - - xi
 notation (selecting functions) - - - - - xi
 PGM STEP - - - - - 7-13
 POS - - - - - 7-13
 positioning speed - - - - - 6-10
 POUT - - - - - 7-13
 product introduction - - - - - 1-2
 program table - - - - - 7-9
 Acceleration rate - - - - - 7-13
 Deceleration rate - - - - - 7-13
 End condition - - - - - 7-13
 Next program step - - - - - 7-13
 Number of loops - - - - - 7-13
 Positioning speed - - - - - 7-13
 Program step - - - - - 7-13
 program table edit - - - - - 10-8
 program table initialization - - - - - 10-17
 Programmable output specification - - - - - 7-13
 Registration distance - - - - - 7-13
 Registration speed - - - - - 7-13
 saving program tables - - - - - 10-12
 state transitions - - - - - 7-26
 Target position - - - - - 7-13
 PULS - - - - - 3-5
 Pulse Reference Input - - - - - 3-5

R

RDST - - - - -	-7-13
registration	
registration distance - - - - -	-7-10
registration operation - - - - -	-7-10
registration speed - - - - -	-6-10
Rotary Servomotor - - - - -	x
RSPD - - - - -	-7-13

S

Servo Drive - - - - -	x
servo lock - - - - -	x
servo OFF - - - - -	x
servo ON - - - - -	x
Servo System - - - - -	x
Servomotor - - - - -	x
SERVOPACK - - - - -	x
ratings - - - - -	2-2
specifications - - - - -	2-5
SigmaWin+ - - - - -	x
SIGN - - - - -	3-5
Sign of Reference Input - - - - -	3-5
signal allocations - - - - -	6-3
SPD - - - - -	-7-13
status display - - - - -	-10-6
Status Monitor - - - - -	5-2
storage humidity - - - - -	2-5
storage temperature - - - - -	2-5
surrounding air humidity - - - - -	2-5
surrounding air temperature - - - - -	2-5

T

TH - - - - -	3-5
Torque Reference Input - - - - -	3-5
T-REF - - - - -	3-5
trial operation example - - - - -	4-2

U

utility function - - - - -	10-2, 10-7
----------------------------	------------

W

warning	
INDEXER module warning displays and	
troubleshooting - - - - -	-8-45
list of warnings - - - - -	-8-38
troubleshooting warnings - - - - -	-8-40

Z

ZONE	
editing ZONE tables - - - - -	10-13
saving ZONE tables - - - - -	10-14
ZONE Output - - - - -	-7-53
ZONE table - - - - -	-7-53
ZONE N - - - - -	-7-53

ZONE P - - - - -	7-53
ZONE signals - - - - -	7-53
ZONE table initialization - - - - -	10-18

Revision History

The revision dates and numbers of the revised manuals are given on the bottom of the back cover.

MANUAL NO. SIEP S800001 84A

Published in Japan November 2015

_____ Date of publication

Date of Publication	Rev. No.	Section	Revised Contents
November 2015	—	—	First edition

Σ-7-Series AC Servo Drive

Σ-7S SERVOPACK with

FT/EX Specification

for Indexing Application

Product Manual

IRUMA BUSINESS CENTER (SOLUTION CENTER)

480, Kamifujisawa, Iruma, Saitama, 358-8555, Japan
Phone 81-4-2962-5151 Fax 81-4-2962-6138
<http://www.yaskawa.co.jp>

YASKAWA AMERICA, INC.

2121, Norman Drive South, Waukegan, IL 60085, U.S.A.
Phone 1-800-YASKAWA (927-5292) or 1-847-887-7000 Fax 1-847-887-7310
<http://www.yaskawa.com>

YASKAWA ELÉTRICO DO BRASIL LTDA.

777, Avenida Piraporinha, Diadema, São Paulo, 09950-000, Brasil
Phone 55-11-3585-1100 Fax 55-11-3585-1187
<http://www.yaskawa.com.br>

YASKAWA EUROPE GmbH

185, Hauptstraße, Eschborn, 65760, Germany
Phone 49-6196-569-300 Fax 49-6196-569-398
<http://www.yaskawa.eu.com>

YASKAWA ELECTRIC KOREA CORPORATION

9F, Kyobo Securities Bldg. 26-4, Yeouido-dong, Yeongdeungpo-gu, Seoul, 150-737, Korea
Phone 82-2-784-7844 Fax 82-2-784-8495
<http://www.yaskawa.co.kr>

YASKAWA ELECTRIC (SINGAPORE) PTE. LTD.

151, Lorong Chuan, #04-02A, New Tech Park, 556741, Singapore
Phone 65-6282-3003 Fax 65-6289-3003
<http://www.yaskawa.com.sg>

YASKAWA ELECTRIC (THAILAND) CO., LTD.

59, 1st-5th Floor, Flourish Building, Soi Ratchadapisek 18, Ratchadapisek Road, Huaykwang, Bangkok, 10310, Thailand
Phone 66-2-017-0099 Fax 66-2-017-0799
<http://www.yaskawa.co.th>

YASKAWA ELECTRIC (CHINA) CO., LTD.

22F, One Corporate Avenue, No.222, Hubin Road, Shanghai, 200021, China
Phone 86-21-5385-2200 Fax 86-21-5385-3299
<http://www.yaskawa.com.cn>

YASKAWA ELECTRIC (CHINA) CO., LTD. BEIJING OFFICE

Room 1011, Tower W3 Oriental Plaza, No.1, East Chang An Ave.,
Dong Cheng District, Beijing, 100738, China
Phone 86-10-8518-4086 Fax 86-10-8518-4082

YASKAWA ELECTRIC TAIWAN CORPORATION

9F, 16, Nanking E. Rd., Sec. 3, Taipei, 104, Taiwan
Phone 886-2-2502-5003 Fax 886-2-2505-1280

YASKAWA

YASKAWA ELECTRIC CORPORATION

In the event that the end user of this product is to be the military and said product is to be employed in any weapons systems or the manufacture thereof, the export will fall under the relevant regulations as stipulated in the Foreign Exchange and Foreign Trade Regulations. Therefore, be sure to follow all procedures and submit all relevant documentation according to any and all rules, regulations and laws that may apply. Specifications are subject to change without notice for ongoing product modifications and improvements.

© 2015 YASKAWA ELECTRIC CORPORATION

MANUAL NO. SIEP S800001 84A

Published in Japan November 2015
15-8-11

Original instructions