

Copyright © 2011 YASKAWA ELECTRIC CORPORATION

All rights reserved. No part of this publication may be reproduced, stored in a retrieval system, or transmitted, in any form, or by any means, mechanical, electronic, photocopying, recording, or otherwise, without the prior written permission of Yaskawa. No patent liability is assumed with respect to the use of the information contained herein. Moreover, because Yaskawa is constantly striving to improve its high-quality products, the information contained in this manual is subject to change without notice. Every precaution has been taken in the preparation of this manual. Nevertheless, Yaskawa assumes no responsibility for errors or omissions. Neither is any liability assumed for damages resulting from the use of the information contained in this publication.

General Precautions

- The drawings presented in this manual are sometimes shown without covers or protective guards. Always replace the cover or protective guard as specified first, and then operate the products in accordance with the manual.
- The drawings presented in this manual are typical examples and may not match the product you received.
- This manual is subject to change due to product improvement, specification modification, and manual improvement. When this manual is revised, the manual code is updated and the new manual is published as a next edition. The edition number appears on the front and back covers.
- Yaskawa will not take responsibility for the results of unauthorized modifications of this product. Yaskawa shall not be liable for any damages or troubles resulting from unauthorized modification.

Safety Information

The following conventions are used to indicate precautions in this manual. Failure to heed precautions provided in this manual can result in serious or possibly even fatal injury or damage to the products or to related equipment and systems.



Indicates precautions that, if not heeded, could possibly result in loss of life or serious injury.



Indicates precautions that, if not heeded, could result in relatively serious or minor injury, damage to the product, or faulty operation.

In some situations, the precautions indicated could have serious consequences if not heeded.



Indicates prohibited actions that must not be performed. For example, this symbol would be used to indicate that fire is prohibited as follows: .





Indicates compulsory actions that must be performed. For example, this symbol would be used as follows to indicate that grounding is compulsory: .

Notes for Safe Operation

WARNING

- Never touch any rotating servomotor parts during operation. Failure to observe this warning may result in injury.
- Before starting operation with a machine connected, make sure that an emergency stop can be applied at any time. Failure to observe this warning may result in injury or damage to the equipment.
- Never touch the inside of the SERVOPACKs. Failure to observe this warning may result in electric shock.
- Immediately after the power is turned OFF or after a voltage resistance test, do not touch terminals. Residual voltage may cause electric shock.
- Follow the procedures and instructions provided in the manuals for the products being used in the trial operation. Failure to do so may result not only in faulty operation and damage to equipment, but also in personal injury.
- The multiturn limit value need not be changed except for special applications. Changing it inappropriately or unintentionally can be dangerous.
- If the Multiturn Limit Disagreement alarm occurs, check the setting of parameter Pn205 in the SERVOPACK to be sure that it is correct.
If Fn013 is executed when an incorrect value is set in Pn205, an incorrect value will be set in the encoder. The alarm will disappear even if an incorrect value is set, but incorrect positions will be detected, resulting in a dangerous situation where the machine will move to unexpected positions.
- Do not remove the cables or connectors from the SERVOPACK while the power is ON. Failure to observe this warning may result in electric shock.
- Do not damage, pull, exert excessive force on, or place heavy objects on the cables. Failure to observe this warning may result in electric shock, stopping operation of the product, or fire.

WARNING

- Do not modify the product.
Failure to observe this warning may result in injury, damage to the equipment, or fire.
- Provide appropriate braking devices on the machine side to ensure safety. The holding brake on a servomotor with a brake is not a braking device for ensuring safety.
Failure to observe this warning may result in injury.
- Do not come close to the machine immediately after resetting an instantaneous power interruption to avoid an unexpected restart. Take appropriate measures to ensure safety against an unexpected restart.
Failure to observe this warning may result in injury.
-  • Connect the ground terminal according to local electrical codes (100 Ω or less).
Improper grounding may result in electric shock or fire.
-  • Installation, disassembly, or repair must be performed only by authorized personnel.
Failure to observe this warning may result in electric shock or injury.

Storage and Transportation

CAUTION

- Do not store or install the product in the following locations. Failure to observe this caution may result in fire, electric shock, or damage to the equipment.
 - Locations subject to direct sunlight
 - Locations subject to temperatures outside the range specified in the storage/installation temperature conditions
 - Locations subject to humidity outside the range specified in the storage/installation humidity conditions
 - Locations subject to condensation as the result of extreme changes in temperature
 - Locations subject to corrosive or flammable gases
 - Locations subject to dust, salts, or iron dust
 - Locations subject to exposure to water, oil, or chemicals
 - Locations subject to shock or vibration
- Do not hold the product by the cables, motor shaft, or encoder while transporting it. Failure to observe this caution may result in injury or malfunction.
- Do not place any load exceeding the limit specified on the packing box. Failure to observe this caution may result in injury or malfunction.
- If disinfectants or insecticides must be used to treat packing materials such as wooden frames, pallets, or plywood, the packing materials must be treated before the product is packaged, and methods other than fumigation must be used.

Example: Heat treatment, where materials are kiln-dried to a core temperature of 56°C for 30 minutes or more.

If the electronic products, which include stand-alone products and products installed in machines, are packed with fumigated wooden materials, the electrical components may be greatly damaged by the gases or fumes resulting from the fumigation process. In particular, disinfectants containing halogen, which includes chlorine, fluorine, bromine, or iodine can contribute to the erosion of the capacitors.

Installation



CAUTION

- Never use the product in an environment subject to water, corrosive gases, flammable gases, or combustibles.
Failure to observe this caution may result in electric shock or fire.
- Do not step on or place a heavy object on the product.
Failure to observe this caution may result in injury or malfunction.
- Do not cover the inlet or outlet ports and prevent any foreign objects from entering the product.
Failure to observe this caution may cause internal elements to deteriorate resulting in malfunction or fire.
- Be sure to install the product in the correct direction.
Failure to observe this caution may result in malfunction.
- Provide the specified clearances between the SERVOPACK and the control panel or with other devices.
Failure to observe this caution may result in fire or malfunction.
- Do not apply any strong impact.
Failure to observe this caution may result in malfunction.

Wiring

CAUTION

- Be sure to wire correctly and securely.
Failure to observe this caution may result in motor overrun, injury, or malfunction.
- Do not connect a commercial power supply to the U, V, or W terminals for the servomotor connection.
Failure to observe this caution may result in injury or fire.
- Securely connect the main circuit terminals.
Failure to observe this caution may result in fire.
- Do not bundle or run the servomotor main circuit cables together with the I/O signal cables or the encoder cables in the same duct. Keep the servomotor main circuit cables separated from the I/O signal cables and encoder cables by at least 30 cm.
Placing these cables too close to each other may result in malfunction.
- Use shielded twisted-pair cables or screened unshielded twisted-pair cables for I/O signal cables and the encoder cables.
- The maximum wiring length is 3 m for I/O signal cables, 50 m for servomotor main circuit cables and encoder cables, and 10 m for power supply cables.
- Install the battery in the battery unit of the encoder cable with a battery unit.
- Voltage remains in the SERVOPACK even after the power supply is turned OFF. To prevent electric shock, do not touch the input terminals for the main circuit power supply or those for the control power supply.
Before wiring or inspections, confirm that the SERVOPACK has completely discharged.
- Be sure to observe the following precautions when wiring the SERVOPACK main circuit terminal blocks.
 - Do not turn the SERVOPACK power ON until all wiring, including the main circuit terminal blocks, has been completed.
 - Remove detachable power supply input connectors or motor connectors from the SERVOPACK before wiring.
- Make sure that the wiring for both the main circuit power supply and control power supply is correct.
Incorrect wiring may cause damage.

CAUTION

- Make sure that the polarity of the input power supply is correct. Incorrect polarity may cause damage.
- Always use the specified power supply voltage. An incorrect voltage may result in fire or malfunction.
- Take appropriate measures to ensure that the input power supply is supplied within the specified voltage fluctuation range. An incorrect power supply may result in damage to the equipment.
- Install external breakers or other safety devices against short-circuiting in external wiring. Failure to observe this caution may result in fire.
- Take appropriate and sufficient countermeasures for each form of potential interference when installing systems in the following locations.
 - Locations subject to static electricity or other forms of noise
 - Locations subject to strong electromagnetic fields and magnetic fields
 - Locations subject to possible exposure to radioactivity
 - Locations close to power suppliesFailure to observe this caution may result in damage to the equipment.
- Do not reverse the polarity of the battery when connecting it. Failure to observe this caution may damage the battery, the SERVO-PACK or servomotor, or cause an explosion.
- Wiring or inspection must be performed by a technical expert.
- Use a 24-VDC or 48-VDC power supply with double insulation or reinforced insulation.
- Failures caused by incorrect wiring or wrong voltage application in the brake circuit may damage the equipment or cause an accident resulting in death or injury. Follow the procedures and instructions for wiring and trial operation precisely as described in the relevant manual.
- When using a detector or a breaker for leakage current, select the appropriate one by considering the grounding conditions and the leakage current of noise filter. For details, contact the manufacturer of the noise filter.

CAUTION

- Motor over-temperature protection is not provided. Motor over-temperature protection shall be provided in the end use when required by the NEC.
When used with Yaskawa servomotor series SGMMV, external over-temperature protection is not needed due to the protection functions in the SERVOPACK and because the motor is rated for continuous torque from 0 to rated speed.
- Incorrect wiring or incorrect voltage application to the output circuit may cause short-circuit.
The above failures will prevent the holding brake from working, which may damage the machine or cause an accident resulting in death or injury.
- Inverting the polarity of the brake signal (/BK), i.e. positive logic, will prevent the holding brake from working in case of its signal line disconnection. If this setting is absolutely necessary, check the operation and confirm that there are no safety problems.
- Provide separate AC/DC power supplies for the main circuits and for controls.
Failure to observe this caution may result in malfunction.
- Do not connect devices (such as motors or solenoids) that greatly change the load or devices (such as electromagnetic switches) that generate surge voltages to the controller power line.
Failure to observe this caution may result in deterioration of the internal elements or a blown fuse.

Operation

CAUTION

- Always use the servomotor and SERVOPACK in one of the specified combinations.
Failure to observe this caution may result in fire or malfunction.
- Conduct trial operation on the servomotor alone with the motor shaft disconnected from the machine to avoid accidents.
Failure to observe this caution may result in injury.

CAUTION

- During trial operation, confirm that the holding brake works correctly. Furthermore, secure system safety against problems such as signal line disconnection.
- Before starting operation with a machine connected, change the parameter settings to match the parameters of the machine. Starting operation without matching the proper settings may cause the machine to run out of control or malfunction.
- Do not turn the power ON and OFF more than necessary. Do not use the SERVOPACK for applications that require the power to turn ON and OFF frequently. Such applications will cause elements in the SERVOPACK to deteriorate. As a guideline, at least one hour should be allowed between the power being turned ON and OFF once actual operation has been started.
- When carrying out JOG operation (Fn002), origin search (Fn003), or EasyFFT (Fn206), forcing movable machine parts to stop does not work for forward overtravel or reverse overtravel. Take necessary precautions. Failure to observe this caution may result in damage to the equipment.
- When using the servomotor for a vertical axis, install safety devices to prevent workpieces from falling due to alarms or overtravels. Set the servomotor so that it will stop in the zero clamp state when overtravel occurs. Failure to observe this caution may cause workpieces to fall due to overtravel.
- When not using the tuning-less function, set the correct moment of inertia ratio (Pn103).
- Setting an incorrect moment of inertia ratio may cause machine vibration.
- Do not touch the SERVOPACK heat sinks or servomotor while power is ON or soon after the power is turned OFF. Failure to observe this caution may result in burns due to high temperatures.
- Do not make any extreme adjustments or setting changes of parameters. Failure to observe this caution may result in injury or damage to the equipment due to unstable operation.

CAUTION

- When an alarm occurs, remove the cause, reset the alarm after confirming safety, and then resume operation.
Failure to observe this caution may result in damage to the equipment, fire, or injury.
- Do not use the holding brake of the servomotor for braking.
Failure to observe this caution may result in malfunction.
- The servomotor will decelerate to a stop if the main-circuit or the control-circuit power supply turns OFF during operation without turning servo OFF.
- An alarm or warning may occur if communications are performed with the host controller while the SigmaWin+ or Digital Operator is operating.
If an alarm or warning occurs, it may stop the current process and stop the system.

Maintenance and Inspection

CAUTION

- Do not disassemble the SERVOPACK and the servomotor.
Failure to observe this caution may result in electric shock or injury.
- Do not attempt to change wiring while the power is ON.
Failure to observe this caution may result in electric shock or injury.
- When replacing the SERVOPACK, resume operation only after copying the previous SERVOPACK parameters to the new SERVOPACK.
Failure to observe this caution may result in damage to the equipment.

Disposal

CAUTION

- When disposing of the products, treat them as ordinary industrial waste.

Warranty Information

Free Warranty Period

This product is warranted for twelve months after being delivered to Yaskawa's customer or if applicable eighteen months from the date of shipment from Yaskawa's factory whichever comes first.

Scope of Warranty

If a Yaskawa product is found to be defective due to Yaskawa workmanship or materials and the defect occurs during the warranty period, Yaskawa will provide a replacement, repair the defective product, and provide shipping to and from the site free of charge.

However, if the Yaskawa Authorized Service Center determines that the problem with a Yaskawa product is not due to defects in Yaskawa's workmanship or materials, then the customer will be responsible for the cost of any necessary repairs.

1 Checking Products on Delivery

Check the following items when the DC Power Input Σ -V Series SERVOPACK is delivered.

Items	Check Method
Is the delivered SERVOPACK the one that was ordered?	Check the model numbers marked on the nameplates of the SERVOPACK. Check the accessories as well.
Is there any damage?	Check the overall appearance, and check for damage or scratches that may have occurred during shipping.
Are there any loose screws?	Check screws for looseness using a screwdriver.

If any of the above items are faulty or incorrect, contact your Yaskawa sales representative or the dealer from whom you purchased the products.

1.1 Nameplate

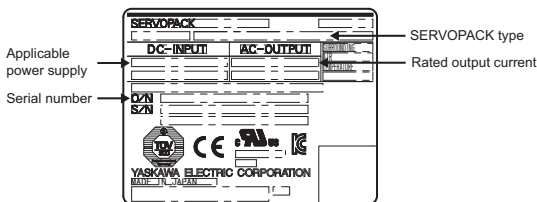

SERVOPACK nameplate

2 Installation

Observe the Installation instructions in *DC Power Input Σ -V Series User's Manual Setup Rotational Motor* (SIEP S800000 80).

For installation sites, use proper care with the following notes.

Situation	Notes on Installation
When installed in a control panel	<ul style="list-style-type: none"> • Design the control panel size, unit layout, and cooling method so that the surrounding air temperature of the SERVOPACK does not exceed 55°C. • When installing multiple SERVOPACKs side by side in a control panel, install cooling fans and provide sufficient space around each SERVOPACK to allow cooling by fan and natural convection.
When installed near a heating unit	Suppress radiation heat from the heating unit and a temperature rise caused by convection so that the surrounding air temperature of the SERVOPACK does not exceed 55°C.
When installed near a source of vibration	Install a vibration isolator underneath the SERVOPACK to prevent it from receiving vibration.
When installed in a place receiving corrosive gases	Corrosive gases do not immediately affect the SERVOPACK but will eventually cause SERVOPACK or contactor-related devices to malfunction. Take appropriate action to protect against corrosive gases.
Others	<ul style="list-style-type: none"> • Avoid installation in a hot and humid place or where excessive dust or iron powder is present in the air. • Be sure there is no condensation or freezing. • Keep the surrounding air temperature 45°C or less to ensure long-term reliability.

3 Wiring

3.1 Input Power Supply, Molded-case Circuit Breaker, and Fuse

Use input power supplies that meet the following conditions.

- The main circuit power supply must be a 24-VDC or a 48-VDC power supply.
- The control circuit power supply must be a 24-VDC power supply.
- The main circuit power supply and the control power supply must be two separate input power supplies.
- Power supplies must have double or reinforced insulation that conforms to safety standards.
- Current limiting function is required for AC/DC converter which is used for main circuit power supply. The current limiting specification must be 50A or less to prevent short-circuit current exceeds 50A under short circuit condition.
- External branch circuit protection must be provided in accordance with the National Electrical Code and local codes.

When choosing molded-case circuit breakers and fuses for input power supplies on the AC side, confirm the specifications of the input power supplies and refer to this table.

Also, choose molded-case circuit breakers and fuses that meet the following cutoff characteristics.

Cutoff characteristics (25°C): ·300% of the rated load input current, five seconds min.

·Does not cut off at the inrush current value of the power supply.

SERVO- PACK Model SGDV-	Main Circuit Power Supply	Max. Applica- ble Servo- motor Capacity [W]	Power Supply Capacity per SERVO- PACK* ¹ [W]	Input Current Capacity			Rated Voltage			
				Main Circuit		Control Circuit* ² [A]	Fuse [V]		MCCB [V]	
				Continu- ous Rated [A]	Instan- taneous Max. [A]		100 V 200 V	400 V	100 V 200 V	400 V
1R7E	DC 24 V	11	108	2.0	5.5	0.3	250	600	240	480
	DC 48 V		169	1.0	4.5					
2R9E	DC 24 V	30	165	3.5	8.5					
	DC 48 V		411	2.0	10.5					

* 1. Values with instantaneous maximum load.

* 2. Values with rated load.

3.2 Names and Functions of Main Circuit Terminals

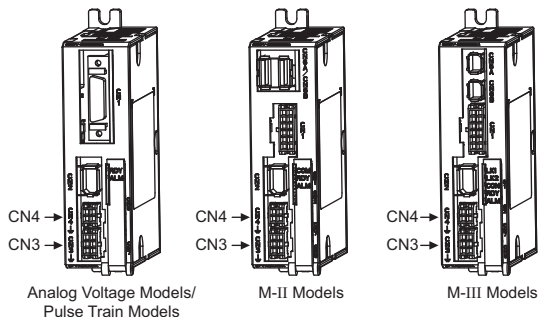

Connector	Terminal Symbols	Pin No.	Name	Description
CN3	L1	6	Main circuit input terminal (+)	24 VDC \pm 15% or 48 VDC \pm 15%
	L2	3	Main circuit input terminal (-)	
	C1	5	Control power input terminal (+)	24 VDC \pm 15%
	C2	4	Control power input terminal (-)	
	\perp	1, 2	Ground terminal	Connect to the ground terminal of the power supply.
CN4	U	1	Servomotor connection terminal (phase U)	Connect to the servomotor.
	V	2	Servomotor connection terminal (phase V)	
	W	3	Servomotor connection terminal (phase W)	
	\perp	4	Ground terminal	Connect to the ground terminal of the servomotor.

3.3 SERVOPACK Main Circuit Cable

Use the following cables for main circuit of the SERVOPACK. These cables are manufactured by YASKAWA Controls Co., Ltd.

Cable	Terminal Symbols	SERVOPACK Model: SGDV-	
		1R7E	2R9E
For power supply	L1, L2, C1, C2, \perp	JZSP-CF1G00-□□-E	
For servomotor main circuit	U, V, W, \perp	JZSP-CF1M00-□□-E (For servomotors without brakes) JZSP-CF1M10-□□-E (For servomotors with brakes) JZSP-CF1M20-□□-E (For servomotors without brakes, flexible type) JZSP-CF1M30-□□-E (For servomotors with brakes, flexible type)	

If you make cables by yourself, read the following items.



IMPORTANT

- Wire sizes are selected for three cables per bundle at 40°C surrounding air temperature with the rated current.
- Use the withstand voltage wires (for 100 V or more)
- Use the wires whose outside diameter of insulator is 1.85 mm or less.
- If cables are bundled in PVC or metal ducts, take into account the reduction of the allowable current.
- Use a heat-resistant wire under high surrounding air or panel temperatures.
- The length of cables for power supply is 10 m max., and the length of cables for servomotor main circuit is 50 m max.

Cable		SERVOPACK Model: SGD V-		Remarks
		1R7E	2R9E	
CN3 for power supply	Connector	43025-0600*		6 poles
	Contact	43030-0001*		–
	For main circuit power supply (L1, L2, $\underline{\underline{\text{PE}}}$)	UL1007, AWG20		Rated voltage 300 V, Rated temperature 80°C
	For control circuit power supply (C1, C2, $\underline{\underline{\text{PE}}}$)	UL1007, AWG20		Rated voltage 300 V, Rated temperature 80°C
CN4 for servo- motor main circuit	Connector (SERVOPACK side)	43025-0400*		4 poles
	Contact (SERVOPACK side)	43030-0001*		–
	Connector (servomotor side, without brake)	43020-0401*		4 poles
	Connector (servomotor side, with brake)	43020-0601*		6 poles
	Contact (servomotor side)	43031-0001*		–
	Power line for servomo- tor main circuit (U, V, W, brake power supply, $\underline{\underline{\text{PE}}}$)	UL1007, AWG20		Rated voltage 300 V, Rated temperature 80°C

* Made by Molex Japan Co., Ltd.

3.4 Typical Main Circuit Wiring Examples



IMPORTANT

- Use a molded-case circuit breaker (1QF) or fuse to protect the servo system.
Always use a molded-case circuit breaker (1QF) or fuse to protect the servo system from accidents involving different power system voltages or other accidents.
- Install a ground fault detector.
The SERVOPACK does not have a built-in protective circuit for grounding.
To configure a safer system, install a ground fault detector against overloads and short-circuiting, or install a ground fault detector combined with a molded-case circuit breaker.
- Do not frequently turn power ON and OFF.
 - Frequently turning power ON and OFF causes elements inside the SERVOPACK to deteriorate. Do not use the servo drive with an application that requires frequently turning power ON and OFF.
 - After the actual operation starts, the allowable interval for turning power ON and OFF is one hour or longer.

The following wiring examples show the DC Power Input Σ -V Series SGDV SERVOPACK (Analog voltage reference model).

■ SGDV-□□□ES1A (□□□ = 1R7, 2R9)

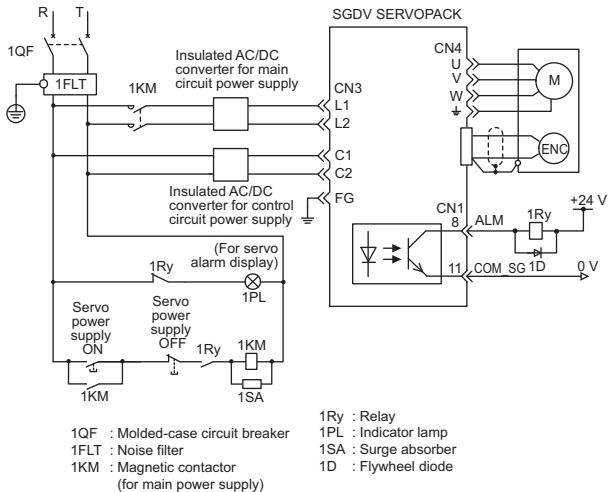

4 Inspection

4.1 SERVOPACK Inspection

For inspections and maintenance of the SERVOPACK, follow the inspection procedures in the table below at least once every year.

Item	Frequency	Procedure	Remedy
Exterior	At least once a year	Check for dust, dirt, and oil on surfaces.	Clean with compressed air or cloth.
Loose screws		Check for loose connector screws.	Tighten any loose screws.

4.2 SERVOPACK's Parts Replacement Schedule

The following electric or electronic parts are subject to deterioration over time. To avoid failure, replace these parts at the frequency indicated.

Refer to the standard replacement period in the following table, contact your Yaskawa representative. After an examination of the part in question, we will determine whether the parts should be replaced or not.

The parameters of any SERVOPACKs overhauled by Yaskawa are reset to the factory settings before shipping. Be sure to confirm that the parameters are properly set before starting operation.

Part	Standard Replacement Period	Operating Conditions
Smoothing capacitor (aluminum electrolytic capacitor)	7 to 8 years	<ul style="list-style-type: none">• Surrounding Air Temperature: Annual average of 30°C• Load Factor: 80% max.• Operation Rate: 20 hours/day max.

5 Compliance with CE Marking

5.1 Installation Conditions of EMC Directive

To adapt the EMC directives (EN55011 group1 classA, EN61800-3) for a combination test using servomotors from the Σ -V mini series and SERVOPACKs from the DC power input Σ -V series, a ferrite core or a noise filter must be used. For details, read the Installation instructions in *DC Power Input Σ -V Series User's Manual Setup Rotational Motor* (SIEP S800000 80).

However, because this product is built-in, check that the following conditions are still met after being installed in the final product.

5.2 Conditions Corresponding to Low Voltage Directive

To adapt SERVOPACKs to the Low Voltage Directive, make sure that the following environmental conditions are met.

- Pollution degree: 2
- Protection class: IP10
- Altitude: 1000 m max.

6 Installation Conditions of UL Standards

To adapt SERVOPACKs to the UL standards, make sure that the following conditions are met.

- Pollution degree: 2
- Protection class: IP10
- Altitude: 1000 m max.
- Short Circuit Current Rating (SCCR): 5000 A
Refer to “3.1 Input Power Supply, Molded-case Circuit Breaker, and Fuse” for details of power supply selection.
- The main circuit power supply and the control power supply must be two separate input power supplies.
- Power supplies must have double or reinforced insulation that conforms to safety standards.

7 Overload Characteristics

The overload detection level is set under hot start^{*1} conditions at a servomotor surrounding air temperature of 40°C.

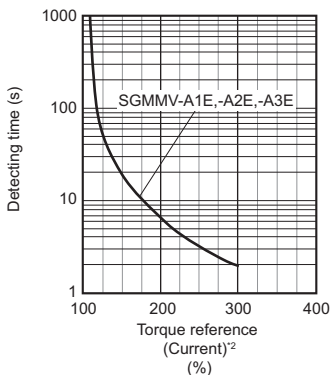
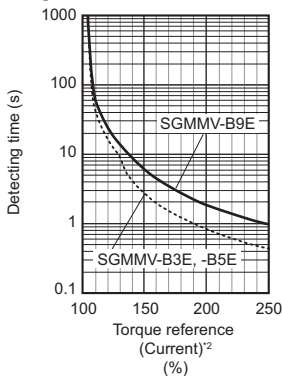

- * 1. A hot start indicates that both the SERVOPACK and the servomotor have run long enough at the rated load to be thermally saturated.
- * 2. The torque reference (current) is indicated as a rate (percentage) in relation to the rated current where the rated current is 100%.

Revision History

The revision dates and numbers of the revised manuals are given on the bottom of the back cover.

MANUAL NO. TOBP C710829 06C

Published in Japan May 2012 11-9 \diamond -1

└─ Date of publication
└─ Date of original publication
└─ WEB revision number
└─ Revision number

Date of Publication	Rev. No.	WEB Rev. No.	Section	Revised Content
May 2013	\diamond 4	0	Back cover	Revision: Address
September 2012	\diamond 3	0	–	Printed version of the user's manual that is available on the web (web version: TOBP C710829 06C<2>-1).
			Back cover	Revision: Address
May 2012	\diamond 2	1	3.1	Revision: Values of the power supply capacity and the input current capacity for the SGDVI1R7E SERVOPACKs
			7	Revision: Torque reference (percent of rated torque) → Torque reference (current)
December 2011	\diamond 1	0	Preface	Revision: Notes of wiring for safe operation
			3.1	Addition: Conditions of input power supplies
			3.2, 3.4	Addition
			6	Addition: Specification of short circuit current rating
			Back cover	Revision: Address
November 2011	\diamond 1	–	Preface	Revision: Notes of wiring and operation for safe operation
September 2011	–	–	–	First edition

AC SERVOPACK

DC Power Input Σ -V Series

SAFETY PRECAUTIONS

IRUMA BUSINESS CENTER (SOLUTION CENTER)

480, Kamifujisawa, Iruma, Saitama 358-8555, Japan
Phone 81-4-2962-5151 Fax 81-4-2962-6138

YASKAWA AMERICA, INC.

2121 Norman Drive South, Waukegan, IL 60085, U.S.A.
Phone 1-800-YASKAWA (927-5292) or 1-847-887-7000 Fax 1-847-887-7310

YASKAWA ELÉTRICO DO BRASIL LTDA.

Avenida Piraporinha 777, Diadema, São Paulo, 09950-000, Brasil
Phone 55-11-3585-1100 Fax 55-11-3585-1187

YASKAWA EUROPE GmbH

Hauptstraße 185, Eschborn 65760, Germany
Phone 49-6196-569-300 Fax 49-6196-569-398

YASKAWA ELECTRIC UK LTD.

1 Hunt Hill Orchardton Woods Cumbernauld, G68 9LF, United Kingdom
Phone 44-1236-735000 Fax 44-1236-458182

YASKAWA ELECTRIC KOREA CORPORATION

9F, Kyobo Securities Bldg. 26-4, Yeouido-dong, Yeongdeungpo-gu, Seoul, 150-737, Korea
Phone 82-2-784-7844 Fax 82-2-784-8495

YASKAWA ELECTRIC (SINGAPORE) PTE. LTD.

151 Lorong Chuan, #04-02A, New Tech Park 556741, Singapore
Phone 65-6282-3003 Fax 65-6289-3003

YASKAWA ELECTRIC (CHINA) CO., LTD.

12F, Carlton Bld., No.21 HuangHe Road, HuangPu District, Shanghai 200003, China
Phone 86-21-5385-2200 Fax 86-21-5385-3299

YASKAWA ELECTRIC (CHINA) CO., LTD. BEIJING OFFICE

Room 1011, Tower W3 Oriental Plaza, No.1 East Chang An Ave.,
Dong Cheng District, Beijing 100738, China
Phone 86-10-8518-4086 Fax 86-10-8518-4082

YASKAWA ELECTRIC TAIWAN CORPORATION

9F, 16, Nanking E. Rd., Sec. 3, Taipei 104, Taiwan
Phone 886-2-2502-5003 Fax 886-2-2505-1280



YASKAWA ELECTRIC CORPORATION

In the event that the end user of this product is to be the military and said product is to be employed in any weapons systems or the manufacture thereof, the export will fall under the relevant regulations as stipulated in the Foreign Exchange and Foreign Trade Regulations. Therefore, be sure to follow all procedures and submit all relevant documentation according to any and all rules, regulations and laws that may apply.

Specifications are subject to change without notice for ongoing product modifications and improvements.

© 2011-2013 YASKAWA ELECTRIC CORPORATION. All rights reserved.

한국 전파법에 관한 주의사항

韓国電波法に關連する注意事項

Precautions for Korean Radio Waves Act

针对韩国电波法的注意事项

사용자 안내문

기종별	사용자 안내문
A 급 기기 (업무용 방송 통신기 자재)	이 기기는 업무용 (A 급) 전자파 적합 기기로서 판매자 또는, 사용자가 이 점을 주의하시기 바라며, 가정외의 지역에서 사용하는 것을 목적으로 합니다.