

YASKAWA AC Drive Option **CC-Link** Technical Manual

Type: SI-C3

To properly use the product, read this manual thoroughly and retain for easy reference, inspection, and maintenance. Ensure the end user receives this manual.

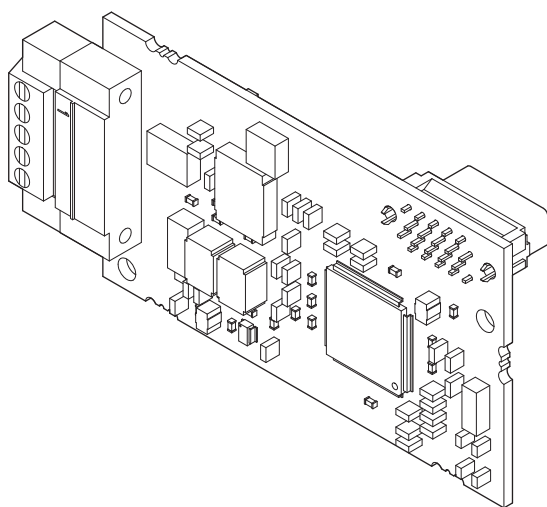

Copyright © 2016 YASKAWA ELECTRIC CORPORATION

All rights reserved. No part of this publication may be reproduced, stored in a retrieval system, or transmitted, in any form, or by any means, mechanical, electronic, photocopying, recording, or otherwise, without the prior written permission of Yaskawa. No patent liability is assumed with respect to the use of the information contained herein. Moreover, because Yaskawa is constantly striving to improve its high-quality products, the information contained in this manual is subject to change without notice. Every precaution has been taken in the preparation of this manual. Yaskawa assumes no responsibility for errors or omissions. Neither is any liability assumed for damages resulting from the use of the information contained in this publication.

Table of Contents

1	PREFACE AND SAFETY	4
2	OVERVIEW	7
3	RECEIVING	9
4	OPTION COMPONENTS	10
5	INSTALLATION PROCEDURE	12
6	RELATED DRIVE PARAMETERS	24
7	BASIC FUNCTIONS	26
8	CC-LINK DATA TABLE	31
9	TROUBLESHOOTING	38
10	CC-LINK CODE NUMBERS	44
11	EUROPEAN STANDARDS	59
12	SPECIFICATIONS	61
13	DISPOSAL	62

1 Preface and Safety

YASKAWA Electric supplies component parts for use in a wide variety of industrial applications. The selection and application of YASKAWA products remain the responsibility of the equipment designer or end user. YASKAWA accepts no responsibility for the way its products are incorporated into the final system design. Under no circumstances should any YASKAWA product be incorporated into any product or design as the exclusive or sole safety control. Without exception, all controls should be designed to detect faults dynamically and fail safely under all circumstances. All products designed to incorporate a component part manufactured by YASKAWA must be supplied to the end user with appropriate warnings and instructions as to the safe use and operation of that part. Any warnings provided by YASKAWA must be promptly provided to the end user. YASKAWA offers an express warranty only as to the quality of its products in conforming to standards and specifications published in the manual. **NO OTHER WARRANTY, EXPRESS OR IMPLIED, IS OFFERED.** YASKAWA assumes no liability for any personal injury, property damage, losses, or claims arising from misapplication of its products.

◆ Applicable Documentation

The following manuals are available for the CC-Link Option:

Option

<p>YASKAWA AC Drive Option CC-Link Installation Manual Manual No.: TOBP C730600 83</p>	<p>This guide is packaged together with the product and contains information necessary to install the option and set related drive parameters.</p>
<p>YASKAWA AC Drive Option CC-Link Technical Manual Manual No.: SIEP C730600 83 (This book)</p>	<p>The technical manual contains detailed information about the option. Access the following sites to obtain the technical manual: U.S.: http://www.yaskawa.com Europe: http://www.yaskawa.eu.com Japan: http://www.e-mechatronics.com Other areas: Check the back cover of these manuals. For questions, contact Yaskawa or a Yaskawa representative.</p>

Drive

<p>YASKAWA AC Drive Manuals</p>	<p>Drive manuals contain basic installation and wiring information in addition to detailed parameter setting, fault diagnostic, and maintenance information. The most recent versions of these manuals are available for download on our documentation websites: U.S.: http://www.yaskawa.com Europe: http://www.yaskawa.eu.com Japan: http://www.e-mechatronics.com Other areas: Check the back cover of these manuals. For questions, contact Yaskawa or a Yaskawa representative.</p>
--	--

◆ Terms

- Note:** Indicates supplemental information that is not related to safety messages.
- Option:** YASKAWA AC Drive Option CC-Link
- Drive:**
- YASKAWA AC Drive 1000-Series (A1000, D1000, U1000, Z1000U)
 - YASKAWA AC Drive GA500
 - YASKAWA AC Drive GA700
 - YASKAWA AC Drive GA800
- Keypad:**
- LCD Operator for YASKAWA AC Drive 1000-Series
 - LED Operator for YASKAWA AC Drive 1000-Series
 - LCD Keypad for YASKAWA AC Drive GA500, GA700, and GA800
 - LED Keypad for YASKAWA AC Drive GA500, GA700, and GA800
- Energy-Saving Unit:** YASKAWA D1000 Series Power Regenerative Converter

◆ Registered Trademarks

- CC-Link is a registered trademark of the CC-Link Partner Association.
 - Other company names and product names listed in this manual are registered trademarks of those companies.
-

◆ Supplemental Safety Information

Read and understand this manual before installing, operating, or servicing this option. The option must be installed according to this manual and local codes.

The following conventions are used to indicate safety messages in this manual. Failure to heed these messages could result in serious or possibly even fatal injury or damage to the products or to related equipment and systems.

DANGER

Indicates a hazardous situation, which, if not avoided, will cause death or serious injury.

WARNING

Indicates a hazardous situation, which, if not avoided, could cause death or serious injury.

CAUTION

Indicates a hazardous situation, which, if not avoided, could cause minor or moderate injury.

NOTICE

Indicates an equipment damage message.

■ General Safety

General Precautions

- The diagrams in this section may include options and drives without covers or safety shields to illustrate details. Be sure to reinstall covers or shields before operating any devices. The option should be used according to the instructions described in this manual.
- The diagrams in this manual are provided as examples only and may not pertain to all products covered by this manual.
- The products and specifications described in this manual or the content and presentation of the manual may be changed without notice to improve the product and/or the manual.
- Contact Yaskawa or a Yaskawa representative and provide the manual number shown on the front cover to order new copies of the manual.

DANGER

Heed the safety messages in this manual.

Failure to comply will cause death or serious injury.

The operating company is responsible for any injuries or equipment damage resulting from failure to heed the warnings in this manual.

WARNING

Electrical Shock Hazard

Do not modify the drive or option circuitry.

Modifications to circuitry can cause serious injury or death, will cause damage to the drive and option, and will void the warranty. Yaskawa is not responsible for modifications of the product made by the user.

NOTICE

Do not use steam or other disinfectants to fumigate wood for packaging the drive or option. Use alternative methods, for example heat treatment, before you package the components.

Gas from wood packaging fumigated with halogen disinfectants, for example fluorine, chlorine, bromine, iodine or DOP gas (phthalic acid ester), can cause damage to the drive and option.

2 Overview

CC-Link Option (Model: SI-C3) is designed for connecting a drive to a field network using the CC-Link protocol. This option conforms to CC-Link Ver.1.10.

Install the option/CC-Link option on a drive to perform the following functions from a CC-Link master device:

- Operate the drive
- Monitor the drive operation status
- Change drive parameter settings



Figure 1 CC-Link Approved

◆ Compatible Products

The option can be used with the products in [Table 1](#).

Table 1 Compatible Products

Product Series	Model(s)	Software Version <1>
A1000	CIMR-A□□A□□□□	≥1020
D1000 <2>	CIMR-D□□A□□□□	≥2005 ≥3013 (for a 400 V class 630 kW unit)
U1000	CIMR-U□□A□□□□	≥1010
	CIMR-U□□E□□□□	
	CIMR-U□□P□□□□	
	CIMR-U□□W□□□□	
Z1000U	CIMR-Z□□A□□□□	≥6110
	CIMR-Z□□E□□□□	
	CIMR-Z□□P□□□□	
	CIMR-Z□□W□□□□	
GA500	CIPR-GA50□□□□	≥1010
GA700	CIPR-GA70□□□□	≥1010
GA800	CIPR-GA80□□□□	≥9010

<1> Refer to “PRG” on the drive nameplate for the software version number.

<2> Before you install the option on a YASKAWA D1000 Series Power Regenerative Converter, make sure that the option software version is PRG: 0106 or later.

Note: Refer to the option package labeling in the field designated “PRG” (four digit number)” or the option labeling in the field designated “C/N” (S + four digit number)” to identify the option software version.

◆ Install the Option on a GA500 Drive

An option card installation case is necessary to install the option on a GA500 drive. The option card installation case model is: JOHB-GA500. This case is sold separately. Refer to the option card installation case manual for more information about installation.

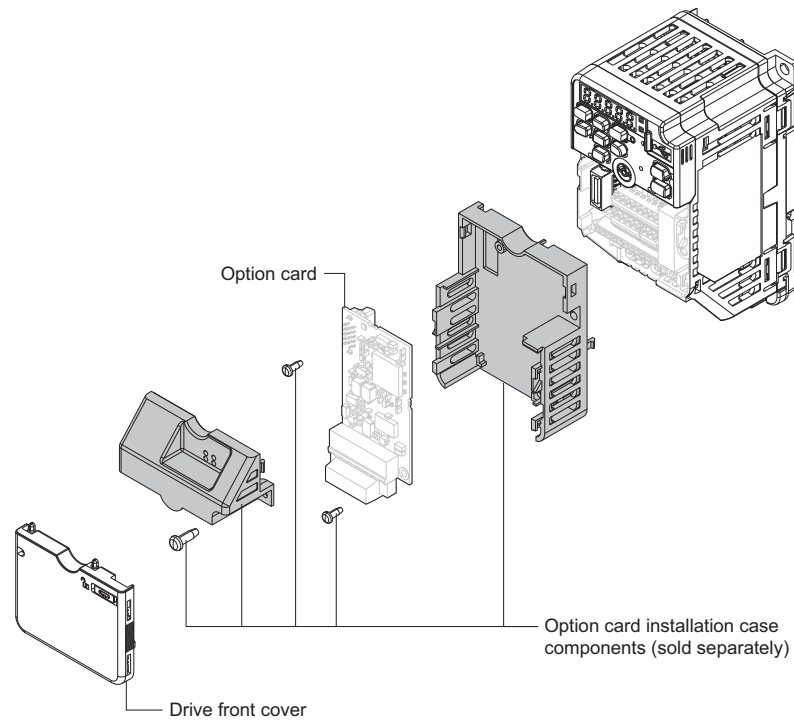

Figure 2 Option Card Installation Case

3 Receiving

After receiving the option package:





1. Make sure that the option is not damaged and no parts are missing. Contact your sales outlet if the option or other parts appear damaged.

NOTICE: Do not use damaged parts to connect the drive and the option. Failure to comply could damage the drive and option.

2. Confirm that the model number on the option nameplate and the model listed in the purchase order are the same. Refer to **Figure 3** on page **10** for details. Contact the distributor where the option was purchased or contact Yaskawa or a Yaskawa representative about any problems with the option.

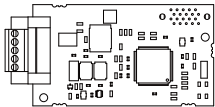
◆ Contents and Packaging

Table 2 Contents of Package

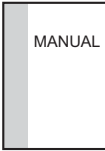
Description:	Option	Ground Wire <1>	Screws	LED Labels		Installation Manual
				1000-Series	GA500, GA700, and GA800	
—						
Quantity:	1	1	3 <2>	1	1	1

<1> GA700 and GA800 drives do not use the ground wire.

<2> GA700 and GA800 drives use two screws only.

◆ Installation Tools

- A Phillips screwdriver. Phillips screw sizes vary by drive capacity.
- A flat-blade screwdriver (blade depth: 0.4 mm (0.02 in), width: 2.5 mm (0.1 in)).
- A pair of diagonal cutting pliers.
- A small file or medium-grit sandpaper.

4 Option Components

◆ CC-Link Option

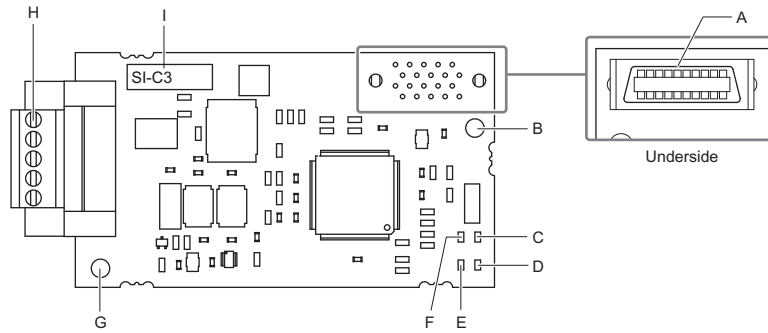

- A – Connector (CN5)
- B – Installation hole
- C – LED (L.RUN) <1>
- D – LED (SD) <1>
- E – LED (RD) <1>
- F – LED (L.ERR) <1>
- G – Ground Terminal (FE) and installation hole <2>
- H – CC-Link Terminal block (CN1)
- I – Option model number

<1> Refer to *Option LED Display on page 11* and *Fault LED Display on Option Side on page 40* for details on the LEDs.

<2> Connect the provided ground wire during installation. Installation on GA700 and GA800 drives does not require the ground wire.

Figure 3 Option Card

◆ Option Modular Connector

Table 3 Option Terminal Descriptions

Terminal	Terminal	Description
1	DA	Communication Data +
2	DB	Communication Data –
3	DG	Signal Ground
4	SLD	Shield
5	SLD	Shield



Figure 4 Option Modular Connector (CN1)

◆ Option LED Display

■ Defining Option LED States

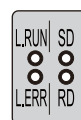

1000-Series Label

GA500, GA700, and GA800 Label

Figure 5 Option LED Labels

Table 4 Option LED States

Name	Indication		Operating Status	Description
	Color	Status		
L.RUN	Green	ON	Normal operation	Receiving data normally
		OFF	Timed out	<ul style="list-style-type: none"> Timed out waiting to receive Logging onto the network During reset
L.ERR	Red	ON	CRC error	<ul style="list-style-type: none"> CRC error Station address setting error (F6-10 = 0)
		OFF	During communications	<ul style="list-style-type: none"> Normal communications During reset
SD	Red	ON	Sending data	Sending data Note: LED may appear to flash with slower baud rates.
		OFF	No data transfer	<ul style="list-style-type: none"> No data being sent During reset
RD	Red	ON	Detecting data received	Detecting data that was received Note: LED may appear to flash with slower baud rates.
		OFF	Waiting for data	<ul style="list-style-type: none"> Data not yet received During reset

◆ Setting Station Address

Set drive parameter F6-10 to a station address (Range 1 to 64) unique to the network. If set to 0, the L.ERR light will turn on and a Station Address Error (AEr) will occur.

5 Installation Procedure

◆ Section Safety

DANGER

Electric Shock Hazard

Do not inspect, connect, or disconnect any wiring while the drive is energized.

Failure to comply will cause death or serious injury.

Before servicing, disconnect all power to the equipment and wait for at least the time specified on the warning label. The internal capacitor remains charged even after the drive is de-energized. The charge indicator LED will extinguish when the DC bus voltage is below 50 Vdc. When all indicators are OFF, measure for unsafe voltages to confirm the drive is safe.

WARNING

Electrical Shock Hazard

Do not operate equipment with covers removed.

Failure to comply could cause death or serious injury.

The diagrams in this section may include options and drives without covers or safety shields to illustrate details. Reinstall covers and shields before operating the drive and run the drive according to the instructions described in this manual.

Do not allow unqualified personnel to perform work on the drive or option.

Failure to comply could cause death or serious injury.

Only authorized personnel familiar with installation, adjustment, and maintenance of AC drives and options may perform work.

Do not remove covers or touch circuit boards while the drive is energized.

Failure to comply could cause death or serious injury.

Do not use damaged wires, stress the wiring, or damage the wire insulation.

Failure to comply could cause death or serious injury.

Fire Hazard

Tighten all terminal screws to the specified tightening torque.

Loose or overtightened connections could cause erroneous operation and damage to the terminal block or start a fire and cause death or serious injury.

NOTICE

Damage to Equipment

Observe proper electrostatic discharge (ESD) procedures when handling the option card, drive, and circuit boards.

Failure to comply could cause ESD damage to circuitry.

Never connect or disconnect the motor from the drive while the drive is outputting voltage.

Improper equipment sequencing could damage the drive.

Do not connect or operate any equipment with visible damage or missing parts.

Failure to comply could further damage the equipment.

NOTICE

Do not use unshielded wire for control wiring.

Failure to comply may cause electrical interference resulting in poor system performance. Use shielded, twisted-pair wires and ground the shield to the ground terminal of the drive.

Properly connect all pins and connectors on the option and drive.

Failure to comply could prevent proper operation and damage equipment.

Confirm that all connections are correct after installing the option and connecting peripheral devices.

Failure to comply could damage the option.

◆ Procedures for Installing and Wiring Options on a Drive

Procedures to install and wire the option are different for different drive models.

Refer to [Table 5](#) to check the procedures to install and wire the option on a drive.

Table 5 Procedures for Installing and Wiring Options on a Drive

Product Series	Procedures for Installing and Wiring Options on a Drive	Page
A1000	Procedure A	14
D1000	Procedure A	14
U1000	Procedure A	14
Z1000U	Procedure A	14
GA500	<1>	–
GA700	Procedure B	18
GA800	Procedure B	18

<1> Use the option card installation case manual to install the option on GA500 drives.

■ Procedure A

This section shows the procedure to install and wire the option on a 1000-series drive.

Prepare the Drive for the Option

Before you install the option on a YASKAWA D1000 Series Power Regenerative Converter, make sure that the option software version is PRG: 0106 or later.

1. Correctly wire the drive as specified by the manual packaged with the drive.
2. Make sure that the drive functions correctly.

Refer to **Figure 6** for an exploded view of the drive with the option and related components for reference in the installation procedure.

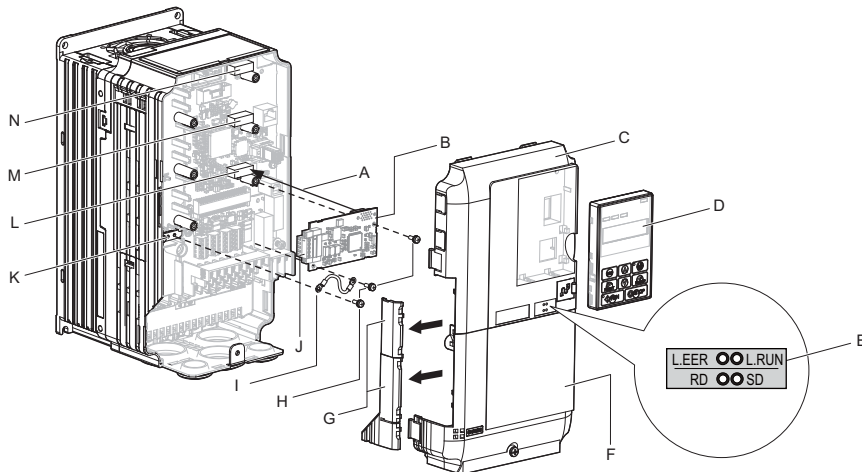

- | | |
|--|--|
| A – Insertion point for CN5 connector | J – Option modular connector CN1 |
| B – SI-C3 option | K – Drive grounding terminal (FE) |
| C – Drive front cover | L – Connector CN5-A |
| D – Keypad | M – Connector CN5-B
(Not available for communication option installation.) |
| E – LED label | N – Connector CN5-C
(Not available for communication option installation.) |
| F – Drive terminal cover | |
| G – Removable tabs for wire routing | |
| H – Included screws | |
| I – Ground wire | |

Figure 6 Drive Components with Option

Install the Option

Remove the front covers of the drive before you install the option.

Refer to the drive manual for information about how to remove the front covers. Different drive sizes have different cover removal procedures.

You can only install this option into the CN5-A connector on the drive control board.

DANGER! Electrical Shock Hazard. Do not inspect, connect, or disconnect any wiring while the drive is energized. Failure to comply will cause death or serious injury. Before servicing, disconnect all power to the equipment and wait for at least the time specified on the warning label. The internal capacitor remains charged even after the drive is de-energized. The charge indicator LED will extinguish when the DC bus voltage is below 50 Vdc. When all indicators are OFF, measure for unsafe voltages to confirm the drive is safe.

1. Shut off power to the drive, wait the appropriate amount of time for voltage to dissipate, then remove the keypad (D) and front covers (C, F).

Refer to the manual packaged with the drive for details on keypad and cover removal.

NOTICE: Damage to Equipment. Observe proper electrostatic discharge (ESD) procedures when handling the option, drive, and circuit boards. Failure to comply could cause ESD damage to circuitry.

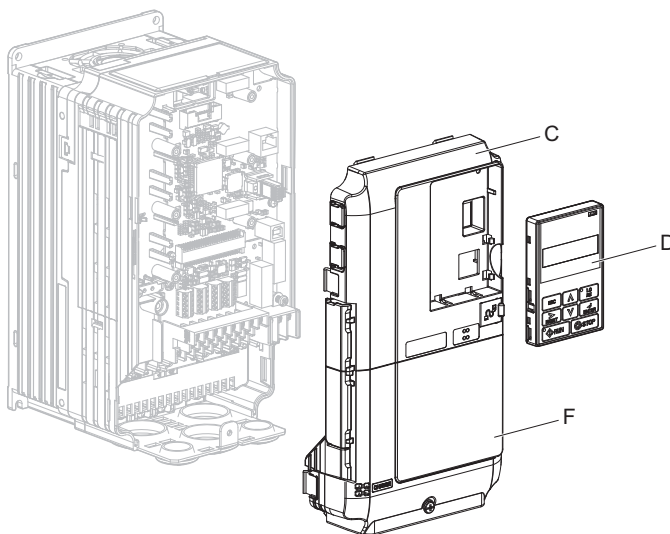

Figure 7 Remove the Keypad, Front Cover, and Terminal Cover

2. Affix the LED label (E) in the appropriate position on the drive front cover (C).

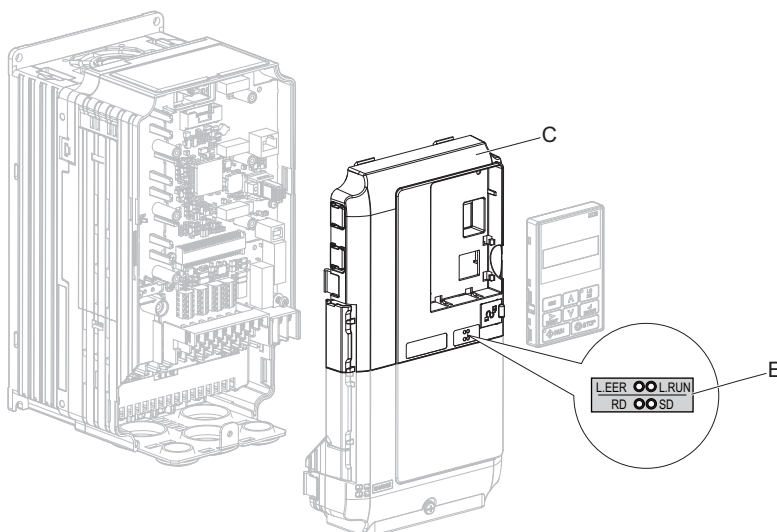

Figure 8 Affix the LED Label

5 Installation Procedure

3. Insert the option card (B) into the CN5-A (L) connector on the drive and fasten it into place using one of the included screws (H). Tighten the screw to 0.5 to 0.6 N·m (4.4 to 5.3 in·lb).

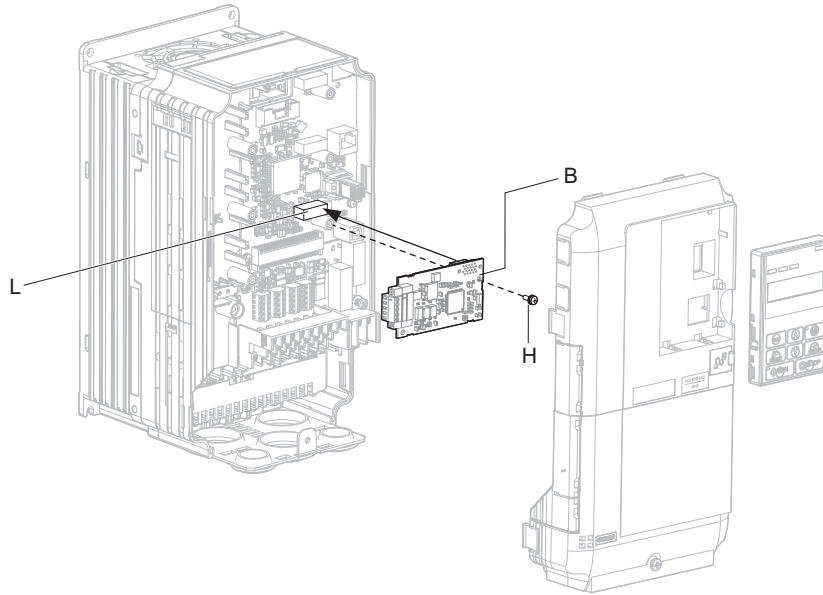

Figure 9 Insert the Option

4. Connect one end of the ground wire (I) to the ground terminal (K) using one of the remaining provided screws (H). Connect the other end of the ground wire (I) to the remaining ground terminal and installation hole on the option (B) using the last remaining provided screw (H). Tighten both screws to 0.5 to 0.6 N·m (4.4 to 5.3 in·lb).

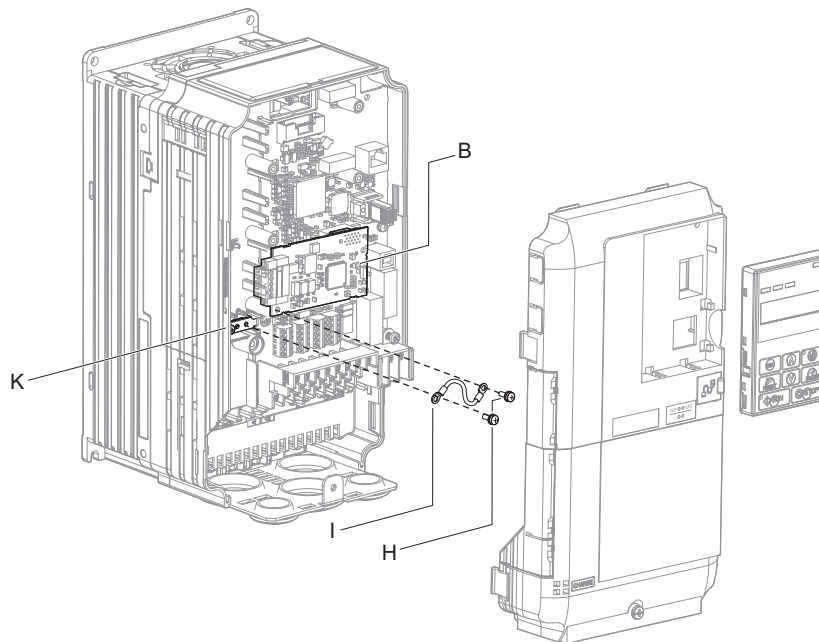

Figure 10 Connect the Ground Wire

Note: The drive has only two ground terminal screw holes (K). Two ground wires should share the same ground terminal when connecting three options.

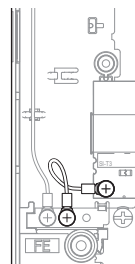

Figure 11 Connecting the Ground Terminal

5. Select the proper CC-Link dedicated communication cable according to [Table 6](#). Route the option wiring inside the enclosure as shown in [Figure 12-B](#). Take proper precautions so that the front covers will easily fit back onto the drive. Users may also choose to route the option wiring through openings on the front cover of some models. Remove the perforated tabs on the left side of the front cover as shown in [Figure 12-A](#) to create the necessary openings on these models. Refer to the Peripheral Devices & Options section of the drive instruction manual for more information.

- Note:**
1. Separate communication cables from main circuit wiring and other electrical lines to avoid potential sources of electrical interference.
 2. Connect the terminator (model No.: JEPMC-W6022-E) to the option modular connector (CN1) on the end drive of the communication lines.

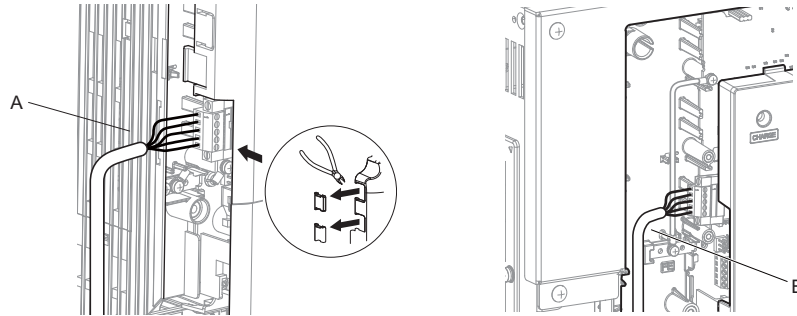

Figure 12 Wire Routing Examples

6. Firmly connect the CC-Link communication cable to option communication connector CN1. Install CC-Link communications cables apart from main-circuit wiring and other electrical and power lines. Ensure the cable end is firmly connected (see [Table 6](#)). Refer to [Communication Cable Topology on page 23](#) for details.
7. Reattach the drive front covers (C, F) and the keypad (D).

NOTICE: Do not pinch cables between the front covers and the drive. Failure to comply could cause erroneous operation.

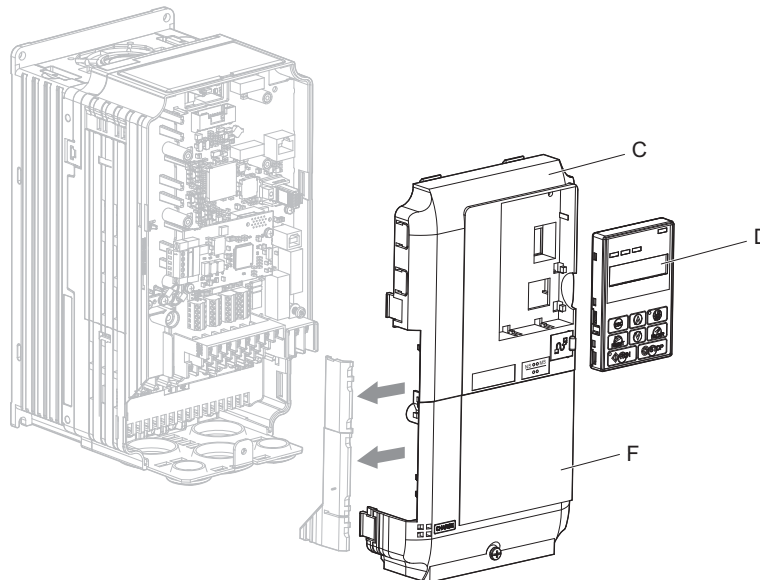

Figure 13 Replace the Front Covers and Keypad

8. Set drive parameters in [Table 7](#) for correct option performance.

■ Procedure B

This section shows the procedure to install and wire the option on a GA700 or GA800 drive.

Prepare the Drive for the Option

1. Correctly wire the drive as specified by the manual packaged with the drive.
2. Make sure that the drive functions correctly.

Refer to **Figure 14** for an exploded view of the drive with the option and related components for reference in the installation procedure.

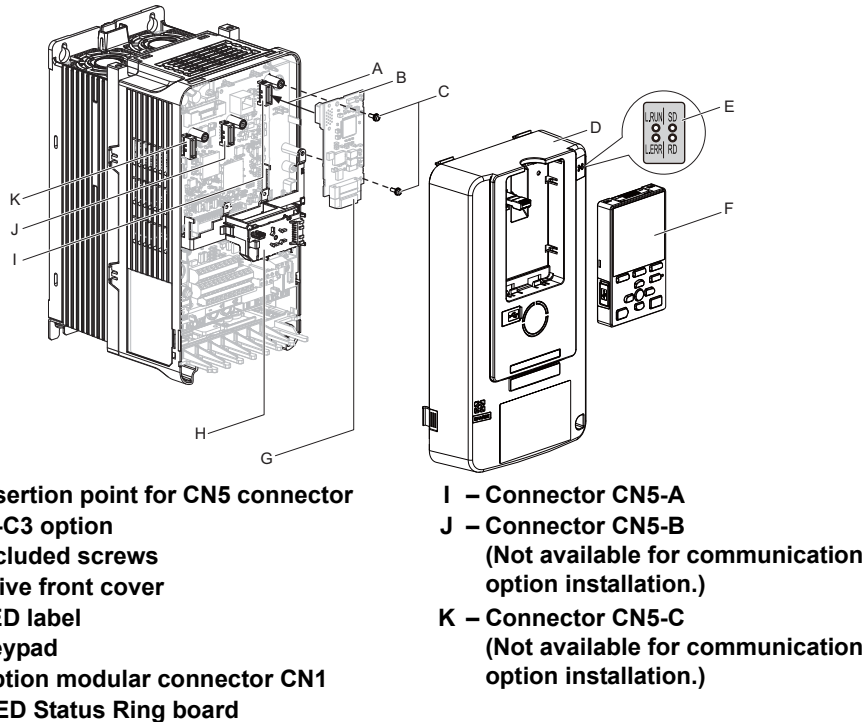

Figure 14 Drive Components with Option

Install the Option

Remove the front cover of the drive before you install the option.

Refer to the drive manual for information about how to remove the front cover. Different drive sizes have different cover removal procedures.

You can only install this option into the **CN5-A** connector on the drive control board.

DANGER! Electrical Shock Hazard. Do not inspect, connect, or disconnect any wiring while the drive is energized. Failure to comply will cause death or serious injury. Before servicing, disconnect all power to the equipment and wait for at least the time specified on the warning label. The internal capacitor remains charged even after the drive is de-energized. The charge indicator LED will extinguish when the DC bus voltage is below 50 Vdc. When all indicators are OFF, measure for unsafe voltages to confirm the drive is safe.

1. Affix the LED label (E) in the appropriate position on the drive front cover (D).

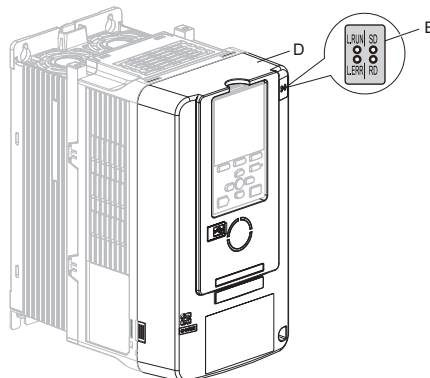

Figure 15 Affix the LED Label

2. Shut off power to the drive, wait the appropriate amount of time for voltage to dissipate, then remove the front cover (D).
Refer to the manual packaged with the drive for details on cover removal.

NOTICE: *Damage to Equipment. Observe proper electrostatic discharge (ESD) procedures when handling the option, drive, and circuit boards. Failure to comply could cause ESD damage to circuitry.*

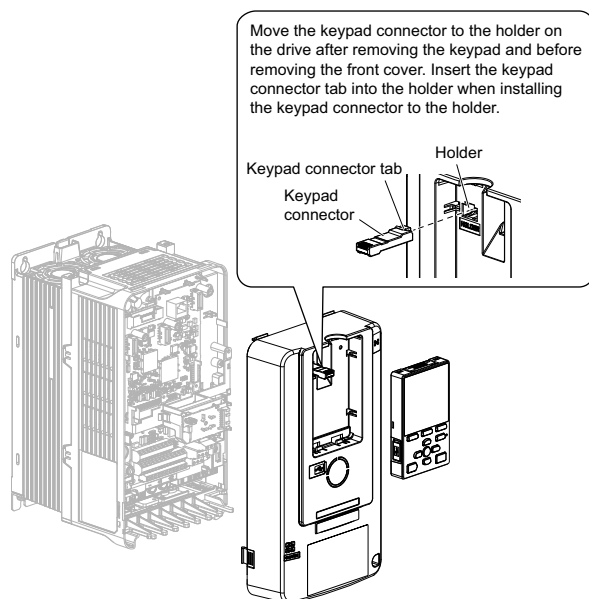

Figure 16 Remove the Front Cover and Keypad

3. Carefully remove the LED Status Ring board (H) and place it on the right side of the drive using the temporary placement holes.
Refer to the manual packaged with the drive for details on removing the LED Status Ring board.

NOTICE: *Do not remove the LED Status Ring board cable connector. Failure to comply could cause erroneous operation and damage the drive.*

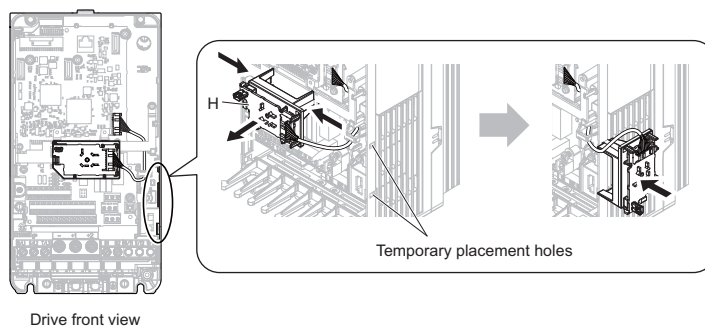

Figure 17 Remove the LED Status Ring Board

5 Installation Procedure

4. Insert the option card (B) into the CN5-A connector (I) on the drive and fasten it into place using the included screws (C). Tighten both screws to 0.5 to 0.6 N·m (4.4 to 5.3 in·lb).

Note: Only two screws are necessary to install the option on a GA700 or GA800 drive. A ground wire is not necessary. The option package ships with three screws and a ground wire for installation on other product series. Do not use the ground wire or the extra screw.

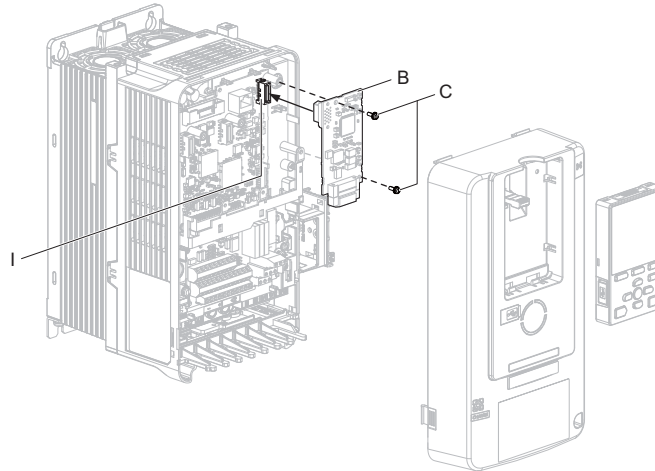

Figure 18 Insert the Option Card

5. Select the proper CC-Link dedicated communication cable according to [Table 6](#). Firmly connect the CC-Link communication cable to option communication connector CN1. Install CC-Link communications cables apart from main-circuit wiring and other electrical and power lines. Ensure the cable end is firmly connected (see [Table 6](#)). Refer to [Communication Cable Topology on page 23](#) for details.

Note: Maximum transmission distance is 100 m (328 ft). Minimum wiring distance between stations is 0.2 m (7.9 in).

6. Reattach the LED Status Ring board (H). Use the open space provided inside the LED Status Ring board to route option wiring.

NOTICE: Do not pinch cables between the front cover or the LED Status Ring board and the drive. Failure to comply could cause erroneous operation.

7. Reattach the drive front cover (D) and the keypad (F).

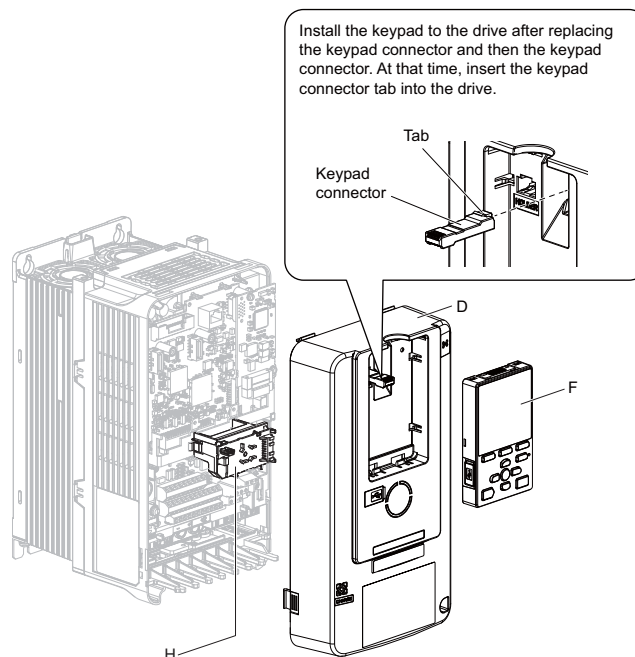

Figure 19 Replace the Front Cover and Keypad

8. Set drive parameters in [Table 7](#) for correct option performance.

◆ Communication Cable Specifications

Use only CC-Link dedicated communication cable; the Yaskawa warranty does not cover other cable types. For more information on cables, refer to the CC-Link website at <http://www.cc-link.org/>.

Yaskawa recommends using CC-Link cables suitable for the conditions listed in [Table 6](#).

Table 6 Communication Cable Requirements

Item		Specifications	
Cable Type		triple-core shielded twisted-pair cable	
External Diameter		8.0 mm maximum	
Drain Wire		20 lines / 0.18 mm or 24 lines / 0.18 mm	
Electrical Characteristics	Conductor Resistance (20°C (68°F))	37.8 Ω/km	
	Insulation Resistance	10000 MΩ·km or greater	
	Voltage Tolerance	500 Vdc, 60 s	
	Capacitance (1 kHz)	60 nF/km maximum	
	Impedance	1 MHz	110 ±15 Ω
		5 MHz	110 ± 6 Ω
Attenuation (20°C (68°F))	1 MHz	1.6 dB / 100 m maximum	
	5 MHz	3.5 dB / 100 m maximum	

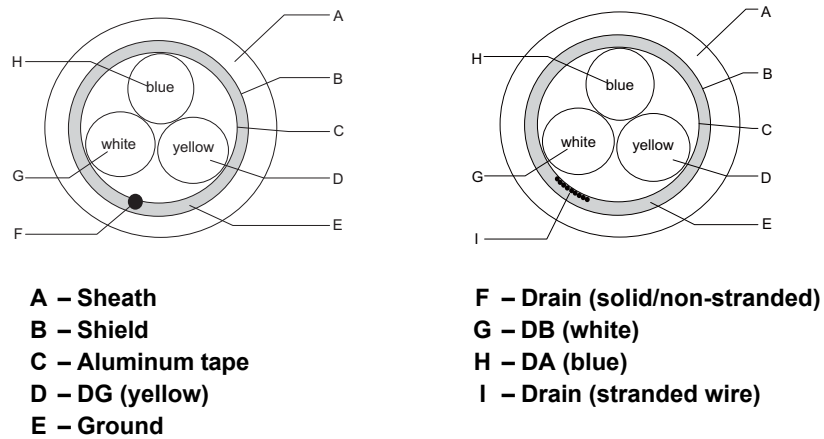

Figure 20 CC-Link Cable Diagram

◆ Option Connection Diagram

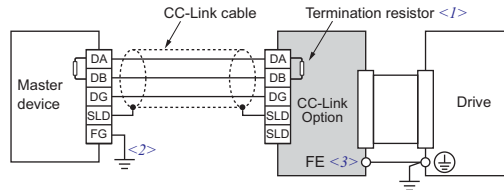

Figure 21 Using a single drive

- <1> The option must be configured with a termination resistor. For instructions, refer to [Termination Resistor Connection on page 23](#).
- <2> Make sure that the FG terminal on the master drive is grounded properly.
- <3> Connect the provided ground wire for installations on 1000-series drives and GA500 drives. The ground wire is not necessary for installation on GA700 or GA800 drives.

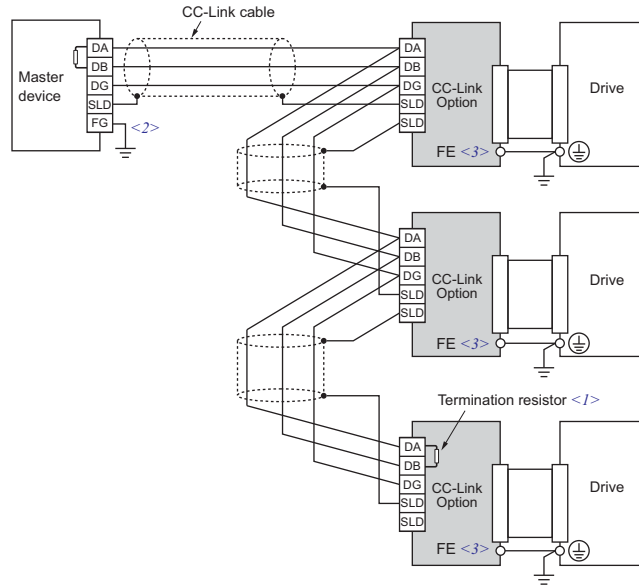

Figure 22 Using multiple drives

- <1> The option must be configured with a termination resistor. For instructions, refer to [Termination Resistor Connection on page 23](#).
- <2> Make sure that the FG terminal on the master drive is grounded properly.
- <3> Connect the provided ground wire for installations on 1000-series drives and GA500 drives. The ground wire is not necessary for installation on GA700 or GA800 drives.

◆ Communication Cable Topology

WARNING! Fire Hazard. Tighten all terminal screws according to the specified tightening torque. Loose electrical connections could result in death or serious injury by fire due to overheating electrical connections. Tightening screws beyond the specified tightening torque may result in erroneous operation, damage to the terminal block, or cause a fire.

Route the option wiring according to the following procedures.

1. Connect the communication cables to the option modular connector CN1 as shown in **Figure 23**.

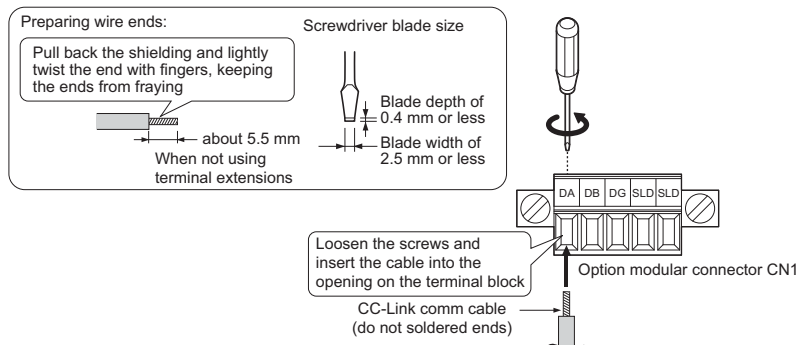

Figure 23 Connect Cable Wiring

2. Take proper precautions to ensure that each cable is properly connected, and that wire insulation is not accidentally pinched into the option modular connector CN1.
3. After the option modular connector CN1 is fully attached to the CC-Link option, tighten the screws on the left and right sides of the option modular connector CN1. (Tightening torque: 0.22 to 0.25 N·m (1.95 to 2.21 in·lb))

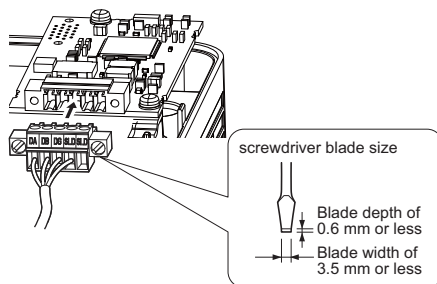

Figure 24 Option Modular Connector CN1 Installation (Ex. GA700)

◆ Termination Resistor Connection

When the CC-Link Option is the last station connected in a CC-Link network, the termination resistor needs to be installed on that CC-Link Option. Cut the ring lugs from the termination resistor leads, and then loosen the DA and DB terminals and insert the termination resistor between terminals DA and DB as shown.

Note: Use the built-in termination resistor from the master if available, otherwise procure a standard-market resistor of 110 Ω, ±5% (1/2 W).

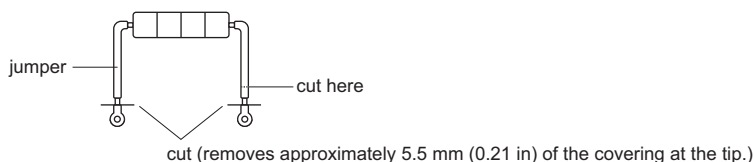

Figure 25 Termination Resistor

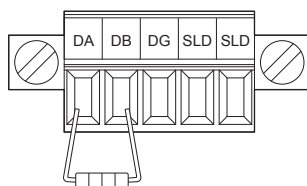

Figure 26 Termination Resistor Wiring

6 Related Drive Parameters

The parameters in **Table 7** set the drive for operation with the option. Confirm proper setting of all parameters in **Table 7** before starting network communications. Refer to the manual packaged with the drive for details on setting parameters.

Note: Hex.: MEMOBUS addresses that you can use to change parameters over network communication are represented in hexadecimal numbers.

Table 7 Parameter Settings

O: Applicable, -: Not applicable, INV: Drive, CNV: Energy-Saving Unit

No. (Hex.)	INV	CNV	Name	Description	Values
b1-01 (0180) <1>	○	-	Reference 1 Source	Selects the input method for frequency reference. 0: Keypad 1: Analog Input 2: Memobus/Modbus Communications 3: Option PCB 4: Pulse Train Input	Default: 1 Range: 0 to 4
b1-02 (0181) <1>	○	○	Run Command 1 Source	Selects the input method for the Run command. 0: Keypad 1: Digital Input 2: Memobus/Modbus Communications 3: Option PCB	Default: 1 Range: 0 to 3
b1-18 (0179) <2>	-	○	Voltage Reference Source	Selects the voltage reference input source. 0: Keypad - RUN and STOP keys 1: Analog input 2: MEMOBUS/Modbus communications 3: Option PCB 7: Input voltage based control 1 8: Input voltage based control 2	Default: 8 Range: 0 to 3, 7, 8
F6-01 (03A2)	○	○	Communications Error Selection	Selects drive response when a bUS error is detected during communications with the option.	-
				When installed to drives: 0: Ramp to stop. 1: Coast to stop. 2: Fast Stop (Use C1-09) 3: Alarm only. <3> 4: Alarm - Run at d1-04 <3> <4> 5: Alarm - Ramp to Stop <4>	Default: 1 Range: 0 to 5 <5>
				When installed to energy-saving units: 1: Stop 3: Alarm Only	Default: 1 Range: 1, 3
F6-02 (03A3)	○	○	Comm External Fault (EF0) Detect	Selects the condition for external fault detection (EF0). 0: Always detected. 1: Detection during run only.	Default: 0 Range: 0, 1
F6-03 (03A4)	○	○	Comm External Fault (EF0) Select	Selects drive response for external fault input (EF0) detection during option communications.	-
				When installed to drives: 0: Ramp to stop. 1: Coast to stop. 2: Fast Stop (Use C1-09) 3: Alarm only. <3>	Default: 1 Range: 0 to 3
				When installed to energy-saving units: 1: Stop 3: Alarm Only	Default: 1 Range: 1, 3
F6-04 (03A5)	○	○	bUS Error Detection Time	Set the maximum time the unit should wait for a communication error to occur (bUS).	Default: 0.0 s <6> Min.: 0.0 s Max.: 5.0 s <7>
F6-06 (03A7) <8> <9>	○	○	Torque Reference/Limit by Comm	Enabling this parameter allows d5-01 to determine whether the value is read as the Torque Limit value (d5-01 = 0) or the Torque Reference value (d5-01 = 1). 0: Disabled 1: Enabled <10>	Default: 0 Range: 0, 1

O: Applicable, -: Not applicable, INV: Drive, CNV: Energy-Saving Unit

No. (Hex.)	INV	CNV	Name	Description	Values
F6-07 (03A8)	○	-	MultiStep Ref Priority Select	0: MultiStep References Disabled 1: MultiStep References Enabled	Default: 0 <11> Range: 0, 1
F6-08 (036A)	○	○	Comm Parameter Reset @Initialize	Selects whether communication-related parameters F6-□□ and F7-□□ are set back to original default values when the drive is initialized using parameter A1-03. 0: No Reset - Parameters retained 1: Reset - Back to factory default Note: The setting value is not changed even when F6-08 is set to 1 and the drive is initialized using A1-03.	Default: 0 Range: 0, 1
F6-10 (03B6) <12> <13> <14>	○	○	CC-Link Node Address	Sets the node address.	Default: 0 Min.: 0 Max.: 64
F6-11 (03B7) <12>	○	○	CC-Link Communication Speed	Sets the communications speed. 0: 156 kbps 1: 625 kbps 2: 2.5 Mbps 3: 5 Mbps 4: 10 Mbps	Default: 0 Range: 0 to 4
F6-14 (03BB)	○	○	CC-Link bUS Error Auto Reset	Enables or disables the Option Communication Error Auto Reset. 0: Disabled 1: Enabled	Default: 0 Range: 0, 1

- <1> Set b1-02 = 3 to start and stop the drive with the CC-Link master device using serial communications.
Set b1-01 = 3 to control the frequency reference of the drive via the master device.
- <2> On D1000, to use the CC-Link master device as the voltage reference, set b1-18 = 3.
- <3> Setting this parameter to 3 or 4 will cause the drive to continue operation after detecting a fault. Take proper measures such as installing an emergency stop switch when using settings 3 or 4.
- <4> Refer to the drive manual to know if settings 4 and 5 are available. Settings 4 and 5 are available in A1000 software versions PRG: 1021 and later.
- <5> The setting range for 1000-Series drives is different for different software versions. Refer to the instruction manual of a specific drive for more information.
- <6> The default setting is 2.0 s, but this default setting will automatically be changed to 0.0 s when CC-Link option is connected.
- <7> When using GA500, the maximum value of F6-04 is 12.0 s.
- <8> When using D1000, the name and description will differ as follows.
<Name>
Active Current Limit from Communications Option
<Description>
Enables or disables the active current limit.
0: Disabled
1: Enabled
- <9> Control method availability of this parameter depends on product series.
 - 1000-Series Drives: Parameter is available in CLV, AOLV/PM, and CLV/PM.
In AOLV/PM, this value is read as the Torque Limit.
 - GA500 Drive: Parameter is available in OLV, AOLV/PM, and EZOLV.
This value is read as the Torque Limit.
 - GA700, GA800 Drives: Parameter is available in OLV, CLV, AOLV, AOLV/PM, CLV/PM, and EZOLV.
In OLV and EZOLV, this value is read as the Torque Limit.
- <10> The setting specifies that network communications provide the torque reference or torque limit. The motor may not rotate if the PLC does not supply a torque reference or torque limit.
- <11> Default setting is 1 for GA500.
- <12> Cycle power for setting changes to take effect.
- <13> All station addresses must be unique.
- <14> A total of 42 nodes can be connected, assuming that all connections are drives.
The following conditions apply when connecting devices that are other drives or energy-saving units to the network:

$$\{(1 \times a) + (2 \times b) + (3 \times c) + (4 \times d)\} \leq 64$$

(a: number of drives that occupies 1 node b: number of drives that occupies 2 nodes)
(c: number of drives that occupies 3 nodes d: number of drives that occupies 4 nodes)

$$\{(16 \times A) + (54 \times B) + (88 \times C)\} \leq 2304$$

(A: number of remote I/O nodes..... 64 max)
(B: number of remote device nodes... 42 max)
(C: number of local nodes..... 26 max)

7 Basic Functions

This interface allows the drive to be connected to a CC-Link network as a remote device, making it possible to operate, adjust settings, and monitor the operation status of the drive using the PLC program. Both bit and word data cyclic transmission are available, and high speed communication up to 10 Mbps is possible.

Below is a description of the basic CC-Link functions that can be performed by the PLC.

Note: Set parameters when operating the drive from a PLC. For instructions, refer to [Related Drive Parameters on page 24](#).

◆ Switching Between Command/Reference Sources

The Run command, Stop command, and the frequency reference can be entered directly from the keypad or given from a separate control device.

To use a separate control device to issue the Run command and frequency reference, the drive needs to be set so that it accepts these commands from an external source such as the Run command source, the frequency reference source, and the voltage reference source.

■ Selecting an External Source

Follow the directions below set the drive up to accept commands from an external controller.

- Using Parameters to Select the Command/Reference Source
- Using the External Terminals to switch the Command/Reference Source
- Using a PLC as the Command/Reference Source

■ Using Parameters to Select the Command/Reference Source

Selecting the Run Command Source

Set b1-02 (Run Command Selection) to 3 (Option PCB).

Selecting the Source of the Frequency Reference

Set b1-01 (Frequency Reference Selection) to 3 (Option PCB).

Selecting the Voltage Reference Source

Set b1-18 (Voltage Reference Source Selection) to 3 (Option PCB).

■ Using the External Terminals to Switch the Command/Reference Source

Selecting the Run Command Source 2

Set b1-16 (Run Command Source 2) to 3 (Option card).

Selecting the Source of the Frequency Reference 2

Set b1-15 (Frequency Reference Source 2) to 3 (Option card).

Selecting the Run Command and Frequency Reference Source

By setting one of the multi-function input terminals S1 through S8 to supply auxiliary reference (H1-01 to H1-08 = 2), then the frequency reference set to b1-15 and the run command source set to b1-16 will become enabled.

■ Using a PLC as the Command/Reference Source

Using Parameters to Switch Sources

Note: By setting H1-□□ = 2, then parameters b1-15 and b1-16 will become enabled when that terminal is switched on.

- Selecting the Run Command Source
Send write data “3” for command code 2181H to the drive or energy-saving unit.
The setting for parameter b1-02 changes to “3”.
- Frequency Reference Source Selection
Send write data “3” for command code 2180H to the drive.
The setting for parameter b1-01 changes to “3”.
- Voltage Reference Source Selection
Send write data “3” for command code 2179H to the energy-saving unit.
The setting for parameter b1-18 changes to “3”.

Using NetRef and NetCtrl

It is also possible to change the source of the frequency reference and the Run command using remote register RW_{w2} command code 00FBH.

If the power is shut off, however, the drive will use the original setting for the command/reference source once the power is turned back again. This method should only be used when briefly switching between command/reference sources.

■ Command/Reference Source Priority Using a PLC

Drive

- Run Command Source

Table 8 Run Command Source Priority

-	Setting Status					
	1	0	0	0	0	0
NetCtrl						
LOCAL/REMOTE Selection	-	LOCAL	REMOTE			
Switching Command Source	-	-	OFF		ON	
Run Command Selection 1 (b1-02)	-	-	3	not 3	-	-
Run Command Selection 2 (b1-16)	-	-	-	-	3	not 3
Run Command Source	PLC	Keypad	PLC	Determined by b1-02	PLC	Determined by b1-16

Note: Dash indicates that the setting has no effect on the source of the Run command.

- Frequency Reference Source

Table 9 Frequency Reference Source Priority

-	Setting Status					
	1	0	0	0	0	0
NetRef						
LOCAL/REMOTE Selection	-	LOCAL	REMOTE			
Switching Reference Source	-	-	OFF		ON	
Frequency Reference Selection 1 (b1-01)	-	-	3	not 3	-	-
Frequency Reference Selection 2 (b1-15)	-	-	-	-	3	not 3
Frequency Reference Source	PLC	Keypad	PLC	Determined by b1-01	PLC	Determined by b1-15

- Note:**
1. When the multi-function input terminals are set up for Multi-Step Speed operation, parameters d1-01 through d1-16 take priority as the source of the frequency reference (assuming that F6-07 = 1).
 2. Dash indicates that the setting has no effect on the source of the frequency reference.
 3. Refer to the technical manual for the drive the CC-Link option is connected to for more details on parameter settings.

7 Basic Functions

Energy-Saving Unit

- Run Command Source

Table 10 Run Command Source Priority

-	Setting Status			
	1	0	0	0
NetCtrl				
LOCAL/REMOTE Selection	-	LOCAL	REMOTE	
Run Command Selection 1 (b1-02)	-	-	3	not 3
Run Command Source	PLC	Keypad	Option	Determined by b1-02

Note: Dash indicates that the setting has no effect on the source of the Run command.

- Voltage Reference Source

Table 11 Voltage Reference Source Priority

-	Setting Status			
	1	0	0	0
NetVol				
LOCAL/REMOTE Selection	-	LOCAL	REMOTE	
Voltage Reference Source Selection (b1-18)	-	-	3	not 3
Voltage Reference Source	PLC	Keypad	Option	Determined by b1-18

Note: 1. Dash indicates that the setting has no effect on the source of the voltage reference.

2. Refer to the instruction manual for the energy-saving unit the CC-Link option is connected to for more details on parameter settings.

◆ Monitors

The user can monitor drive operating status from a PLC.

To do so, the monitor should be set up as follows:

1. Sets the monitor code to the remote register RW_{W0} .
2. Switch the RYC signal on.
Data for the monitor code is stored in the PLC's buffer memory.

Note: Monitor codes and drives are listed in [Drive Monitor Codes on page 47](#) or [Energy-Saving Unit Monitor Codes on page 54](#).

◆ Reading and Setting Parameters

The PLC can write drive parameters, read drive data and operation status, and change settings.

Follow the directions below.

1. Set the command code to remote register RW_{W2} .
Set the write data to RW_{W3} as needed.
2. Switch on the RYF signal (request to execute the command code).
 - Drive executes the process and reply data that correspond with the command code.
 - Command codes for drive parameters should be calculated by adding the values shown below to the MEMOBUS/Modbus register number.

Read command code: MEMOBUS/Modbus register + 1000H

Write command code: MEMOBUS/Modbus register + 2000H

EXAMPLE: Acceleration time command code for C1-01 is 200H. Get the read command code by adding 1000H, yielding 1200H

- Note:**
1. For a list of command codes, write data drives, and setting ranges, refer to [Drive Command Codes on page 44](#), [Drive Extended Command Codes on page 45](#), [Energy-Saving Unit Command Codes on page 52](#), or [Energy-Saving Unit Extended Command Codes on page 53](#).
 2. Refer to the MEMOBUS/Modbus Data Table in Appendix C of the instruction manual for the drive the CC-Link option is connected to for a list of monitor data using the MEMOBUS/Modbus message area.

■ Access Method to Parameter of MEMOBUS Register Number 1000H or Later

When setting and reading parameters of the MEMOBUS register number 1000H or later from the PLC, set the MEMOBUS register number 1000H or later to the register number 0C00H to 0C0FH from the CC-Link communications. The user can access the value of the parameters 1000H or later specified by the MEMOBUS register number 0C00H to 0C0FH with the register number 0C80H to 0C8FH. This function is available in the option versions PRG:0103 and later.

Table 12 List of MEMOBUS Register Numbers and Descriptions

MEMOBUS Register Number	Descriptions
0C00H	Register number setting 1
0C01H	Register number setting 2
0C02H	Register number setting 3
0C03H	Register number setting 4
0C04H	Register number setting 5
0C05H	Register number setting 6
0C06H	Register number setting 7
0C07H	Register number setting 8
0C08H	Register number setting 9
0C09H	Register number setting 10
0C0AH	Register number setting 11
0C0BH	Register number setting 12
0C0CH	Register number setting 13
0C0DH	Register number setting 14
0C0EH	Register number setting 15
0C0FH	Register number setting 16
0C80H	Parameter contents of register number in setting 1
0C81H	Parameter contents of register number in setting 2
0C82H	Parameter contents of register number in setting 3
0C83H	Parameter contents of register number in setting 4
0C84H	Parameter contents of register number in setting 5
0C85H	Parameter contents of register number in setting 6
0C86H	Parameter contents of register number in setting 7
0C87H	Parameter contents of register number in setting 8
0C88H	Parameter contents of register number in setting 9
0C89H	Parameter contents of register number in setting 10
0C8AH	Parameter contents of register number in setting 11
0C8BH	Parameter contents of register number in setting 12
0C8CH	Parameter contents of register number in setting 13
0C8DH	Parameter contents of register number in setting 14
0C8EH	Parameter contents of register number in setting 15
0C8FH	Parameter contents of register number in setting 16

7 Basic Functions

The example below shows reading and setting parameters.

- Example 1: When setting 256 (100H) to the parameter of the MEMOBUS register number 1200H
 - Write the register number (1200 H) that you want to set to register number 0C00H (register number setting 1)
 - Write the value (100H) to be written to register number 1200H in register number 0C80H

Details for settings and readings are as follows:

1. Set the command code (2C00H) to remote register RW_{W2} .
 2. Set the write data (1200H) to remote register RW_{W3} .
 3. Switch on the RYF signal (request to execute the command code).
 4. Set the command code (2C80H) to remote register RW_{W2} .
 5. Set the write data (100H) to remote register RW_{W3} .
 6. Switch on the RYF signal (request to execute the command code).
256(100H) is set to the parameter of register number 1200(H).
- Example 2: When reading the parameter of the MEMOBUS register number 1500H with the register number setting 9
 - Write the register number (1500H) that you want to set to register number 0C08H (register number setting 9)
 - Read the value of the register number 1200H from the register number 0C88H

Details for settings and readings are as follows:

1. Set the command code (2C08H) to remote register RW_{W2} .
2. Set the write data (1500H) to remote register RW_{W3} .
3. Switch on the RYF signal (request to execute the command code).
4. Set the command code (1C88H) to remote register RW_{W2} .
5. Switch on the RYF signal (request to execute the command code).
The parameter value of register number 1500H is stored in remote register RW_{R3} .

8 CC-Link Data Table

◆ Remote I/O

The drive takes up a single station address in the buffer memory or the PLC. The table below shows the drive I/O as seen from the PLC side.

- Note:**
1. Remote I/O data varies between drives and energy-saving units.
 2. Refer to the PLC's programming manual for information on the PLC's buffer memory.

■ Drive Remote I/O

PLC → Drive

Table 13 Remote I/O Table (PLC → Drive)

Signal	Name	Description	Default
RY0	Forward Run	ON: Forward Run Command, OFF: Stop	–
RY1	Reverse Run	ON: Reverse Run Command, OFF: Stop	–
RY2	Terminal S3 Function	Multi-function input: H1-03	H1-03 = 24: External Fault
RY3	Terminal S4 Function	Multi-function input: H1-04	H1-04 = 14: Fault Reset
RY4	Terminal S5 Function	Multi-function input: H1-05	H1-05 = 3: Multi-Step Speed 1
RY5	Terminal S6 Function	Multi-function input: H1-06	H1-06 = 4: Multi-Step Speed 2
RY6	Terminal S7 Function	Multi-function input: H1-07	H1-07 = 6: Jog Reference
RY7	YASKAWA AC Drive 1000-Series, GA700 or GA800: Terminal S8 Function GA500: Reserved	YASKAWA AC Drive 1000-Series, GA700 or GA800: Multi-function input: H1-08 GA500: -	YASKAWA AC Drive 1000-Series, GA700 or GA800: H1-08 = 8: baseblock command GA500: -
RY8	Reserved	–	–
RY9	Drive Output Interrupt	ON: Motor coasts to stop. OFF: Drive will begin operating as soon as a Run command is given.	–
RYA	External Fault	ON: External Fault Input (EF0)	–
RYB	Motor Revolutions / Output Frequency Switch	Sets data contents for the remote register RW_{R1} . ON: Output frequency OFF: Motor revolutions	Disabled in V/f Control or PM Open Loop Vector mode. RW_{R1} is the output frequency.
RYC	Monitor Reference	ON: Monitor data specified in the monitor code is set to remote register RW_{R0} .	When switching between monitors using RYC (Monitor Reference), RYC needs to be turned off and then back on again after the monitor code has been changed.
RYD	Frequency Reference 1	Frequency set to remote register RW_{W1} becomes the operating frequency for the drive.	When switching on RYD, the frequency in the remote register RW_{W1} will always reflect the operating frequency for the drive.
RYE	Frequency Reference 2	Sets the frequency in the remote register RW_{W1} to parameter d1-01 (Frequency Reference 1) and as the drive's main frequency reference at the same time. Note: If the frequency reference is set to be provided by the keypad (i.e. b1-01 = 0), then switching on RYE changes the frequency reference.	All parameter settings are saved when this flag is switched on. Triggered by the rising edge of the signal.
RYF	Command Code Execute Request	Request to execute the command code.	Triggered by the rising edge of the signal.
RY10 to 13	Reserved	–	–
RY14	Terminal S1 Function	Multi-function input: H1-01	Function is disabled when for the Forward Run Command (H1-01 = 40).

8 CC-Link Data Table

Signal	Name	Description	Default
RY15	Terminal S2 Function	Multi-function input: H1-02	Function is disabled when for the Reverse Run Command (H1-02 = 41).
RY16 to 19	Reserved	–	–
RY1A	Fault Reset	Resets a drive fault	–
RY1B to 1F	Reserved	–	–

Note: 1. If making frequent setting changes, use RYD (Frequency Reference 1 flag) for setting the register. You can write data to the EEPROM used for the drive 100,000 times. Do not use this write command frequently.

2. Although RYE and RYF are triggered by the rising edge of the signal, they are otherwise enabled depending on the value that is input.

Drive → PLC

Table 14 Remote I/O Table (Drive → PLC)

Device	Signal Name	Description	Default
RX0	Forward Run	ON: Forward Run Command Present (includes DC Injection Braking) OFF: No Forward Run Command	–
RX1	Reverse Run	ON: Reverse Run Command Present OFF: No Reverse Run Command (includes DC Injection Braking)	–
RX2	YASKAWA AC Drive 1000-Series: Terminals M1, M2 Function YASKAWA AC Drive GA700, GA800: Multi-function digital output 1 Function GA500:Terminals MA/MB-MC Function	Multi-function output: H2-01	YASKAWA AC Drive 1000-Series, GA700, GA800: H2-01 = 0: During Run GA500: H2-01 = E: Fault
RX3	Speed Agree	ON: Output frequency is between frequency reference and the detection width set to L4-02.	–
RX4	During Stall Prevention	–	–
RX5	During Undervoltage	–	–
RX6	YASKAWA AC Drive 1000-Series, GA500: Terminal P1 Function </> YASKAWA AC Drive GA700, GA800: Multi-function digital output 2 Function	Multi-function output: H2-02	YASKAWA AC Drive 1000-Series, GA700, GA800: H2-02 = 1: Zero Speed GA500: H2-02 = 0: During Run
RX7	YASKAWA AC Drive 1000-Series, GA500: Terminal P2 Function </> YASKAWA AC Drive GA700, GA800: Multi-function digital output 3 Function </>	Multi-function output: H2-03	H2-03 = 2: Speed Agree 1
RX8, 9	Reserved	–	–
RXA	CC-Link Option Fault	Communication error between drive and CC-Link device	–
RXB	Monitoring Motor Revolutions	ON: Currently monitoring motor revolutions.	Data is stored in remote register RW _{R1} .
RXC	Obtain Monitor Data	ON: Monitor data has been updated.	–
RXD	Frequency Setting Ready 1	ON: Displays the main frequency reference that has been set.	–
RXE	Frequency Setting Ready 2	ON: Displays the data set to d1-01 (Frequency Reference 1). Note: Also sets the main frequency reference at the same time.	–
RXF	Command Code Execute Complete	ON: Displayed after the specified command code has been executed. RXF signal switches off when the RYF command is no longer present.	–
RX10 to 19	Reserved	–	–
RX1A	Error	ON: Fault occurred on the drive side.	–
RX1B	Remote Station Ready	ON: Drive is ready to operate.	–
RX1C to 1F	Reserved	–	–

</> Terminals will differ depending on the model of the drive. Refer to [Terminals that Change depending on the Model of the Drive on page 37](#) for information on terminals.

Note: If making frequent setting changes, use RYD (Frequency Reference 1 flag) for setting the register. Using RYE (Frequency Reference 2 flag) too often can shorten the performance life of the drive's internal memory.

■ Energy-Saving Unit Remote I/O

PLC → Energy-Saving Unit

Table 15 Remote I/O Table (PLC → Energy-Saving Unit)

Device	Name	Description	Default
RY0	Run Command/Automatic Run Command	ON: Run Command/Automatic Run Command, OFF: Stop Command	–
RY1	Forced Run Command	ON: Forced Run Command, OFF: Stop	–
RY2	Terminal S3 Function	Multi-Function Input: H1-03	H1-03 = 24: External Fault
RY3	Terminal S4 Function	Multi-Function Input: H1-04	H1-04 = 14: Fault Reset
RY4	Terminal S5 Function	Multi-Function Input: H1-05	H1-05 = F: Through Mode
RY5	Terminal S6 Function	Multi-Function Input: H1-06	H1-06 = F: Through Mode
RY6	Terminal S7 Function	Multi-Function Input: H1-07	H1-07 = F: Through Mode
RY7	Terminal S8 Function	Multi-Function Input: H1-08	H1-08 = 8: Baseblock command (N.O.)
RY8	Reserved	–	–
RY9	External Baseblock Command	ON: No converter output	–
RYA	External Fault	ON: External Fault Input (EF0)	–
RYB	Reserved	–	–
RYC	Monitor Reference	ON: Monitor data specified in the monitor code is set to remote register RW_{R0} .	When switching between monitors using RYC (Monitor Reference), RYC needs to be turned off and then back on again after the monitor code has been changed.
RYD, E	Reserved	–	–
RYF	Command Code Execute Request	Request to execute the command code.	Triggered by the rising edge of the signal.
RY10	Terminals M1-M2 Function	Multi-Function Relay Output 1 (terminal M1-M2)	–
RY11	Terminals P1-PC Function <1>	Multi-Function Photocoupler Output 1 (terminal P1-PC)	–
RY12	Terminals P2-PC Function <1>	Multi-Function Photocoupler Output 2 (terminal P2-PC)	–
RY13	Reserved	–	–
RY14	Terminal S1 Function	Multi-Function Input: H1-01	Function is disabled when for the Run Command (H1-01 = 4B).
RY15	Terminal S2 Function	Multi-Function Input: H1-02	Function is disabled when for the Stop Command (H1-02 = 4C).
RY16	RY17 Enabled/Disabled Selection	–	–
RY17	Terminal MA/MB-MC Function	Fault Contact Output (terminal MA/MB-MC)	–
RY18, 19	Reserved	–	–
RY1A	Fault Reset	Resets an energy-saving unit fault.	–
RY1B to 1F	Reserved	–	–

<1> Terminals will differ depending on the model of the drive. Refer to [Terminals that Change depending on the Model of the Drive on page 37](#) for information on terminals.

Note: Although RYF is triggered by the rising edge of the signal, they are otherwise enabled depending on the value that is input.

Energy-Saving Unit → PLC

Table 16 Remote I/O Table (Energy-Saving Unit → PLC)

Device	Name	Description	Default
RX0	During Run/During Stop	ON: During Run, OFF: During Stop	–
RX1	During Regeneration	ON: During Regeneration	–
RX2	Terminals M1-M2 Function	Multi-function output: H2-01	H2-01 = 25: During Run 1
RX3	During Run (Converter Ready)	–	–
RX4	Reserved	–	–
RX5	Undervoltage (Uv)	–	–
RX6	Terminals P1-PC Function </>	Multi-function output: H2-02	H2-02 = 26: During MC ON
RX7	Terminals P2-PC Function </>	Multi-function output: H2-03	H2-03 = 6: Energy-Saving Unit Ready
RX8	Momentary Power Loss Ride-Thru/Recovery from Momentary Power Loss	–	–
RX9	ComCtrlstatus/NetCtrlstatus	–	–
RXA	CC-Link Option Fault	Communication error between energy-saving unit and CC-Link device	–
RXB	During Active Current Limit	–	–
RXC	Obtain Monitor Data	ON: Monitor data has been updated.	–
RXD	Alarm	–	–
RXE	Fault	–	–
RXF	Command Code Execute Complete	ON: Displayed after the specified command code has been executed. RXF signal switches off when the RYF command is no longer present.	–
RX10	During Reset Signal Input	–	–
RX11	oPE Error	–	–
RX12	Power Supply Undervoltage (AUv)	–	–
RX13 to 19	Reserved	–	–
RX1A	Error	ON: Fault occurred on the energy-saving unit side.	–
RX1B	Remote Station Ready	ON: Energy-saving unit is ready to operate.	–
RX1C to 1F	Reserved	–	–

<1> Terminals will differ depending on the model of the drive. Refer to [Terminals that Change depending on the Model of the Drive on page 37](#) for information on terminals.

◆ Remote Register

Note: Remote register data varies between drives and energy-saving units.

■ Drive Remote Register

PLC → Drive

Table 17 Remote Register (PLC → Drive)

Remote Register	Name	Description	Request Flag
RW _{W0}	Monitor Code	<ul style="list-style-type: none"> • Sets the code number of the items to be displayed by the monitor. (Refer to Drive Monitor Codes on page 47). • Once the monitor code has been set, the monitor value is stored in register RW_{R0} by enabling RYC (the monitor execute request flag). • While RW_{R0} is updated, RXC (during monitor flag) remains on. 	RYC (Monitor Execute Request)
RW _{W1}	Frequency Setting	<ul style="list-style-type: none"> • Specifies the source of the frequency reference. The value set to this register becomes the main frequency reference whenever RYD (frequency setting reference 1) is enabled. • When RYE (frequency setting reference 2 flag) is enabled, then the value for frequency reference 1 is written and saved to EEPROM </>. <p>Note: Parameter o1-03 determines the setting drives for the frequency reference.</p>	<ul style="list-style-type: none"> • RYD (Frequency Reference 1) • RYE (Frequency Reference 2)

Remote Register	Name	Description	Request Flag
RW _{W2}	Command Code	<ul style="list-style-type: none"> Sets the command code to execute functions such as the fault reset, fault history, parameter read, and so on. (Refer to Drive Command Codes on page 44, Drive Extended Command Codes on page 45.) When RYF (command code execution request flag) is enabled, the drive executes the specified command. Once the command has been carried out, RXF switches on. Note: The value set to RW_{W3} (write data) should be adjusted accordingly to match changes to any parameter settings. 	RYF (Command Code Execute Request)
RW _{W3}	Write Data	<ul style="list-style-type: none"> Sets the value to be used along with RW_{W2} (Command Code) as needed. RYF (command code execution request flag) needs to be enabled after the command code and write data have been set. 	

<1> Refrain from saving data to the EEPROM excessively because the EEPROM used in the drive can only be written to 100,000 times.

Drive → PLC

Table 18 Remote Register (Drive → PLC)

Remote Register	Name	Description	Check Flag
RW _{R0}	Monitor Data	<ul style="list-style-type: none"> Monitor data is stored according to RW_{W0} (Monitor Code). Monitor data is updated while RYC (monitor execute request flag) is enabled. RXC (during monitor) remains on as data is updated. 	RXC (while monitoring)
RW _{R1}	Output Frequency	<ul style="list-style-type: none"> Motor revolutions or output frequency has been set without errors. Sets data contents with RYB (Motor Revolutions/ Output Frequency Switch). When RYB is disabled, the output frequency are stored. Set in the drives specified by o1-03 (Frequency Reference Setting Drives) in output frequency. Example: When o1-03 = 0, the frequency is displayed in 0.01 Hz. When o1-03 = 2, the frequency is displayed as r/min. When RYB is enabled, the motor revolutions are stored as r/min. Here, RXB (actual motor rotations) is enabled. <p>The output frequency are stored in V/f Control or PM Open Loop Vector mode. RYB setting is disabled.</p>	RXB (actual motor rotations)
RW _{R2}	Response Code	<ul style="list-style-type: none"> Sets 00H when there are no problems with RW_{W2} (Command Code) and RW_{W3} (Write Data). Sets 01H through 03H if an error occurs. Response Code: 00h: Normal 01h: Write-mode error (attempted to write during run, etc.) 02h: Command code error 03h: Data setting range error 	RXF (Command Code Execute Complete)
RW _{R3}	Read Data	Data is set according to the command code.	

Data in RW_{R1} (Output Frequency) and Units

Table 19 Drive RW_{R1} Data

Conditions		Drive → PLC		
A1-02 (Control Method Selection)	RYB (Motor Revolutions/ Output Frequency Switch)	RXB (Actual Motor Rotations)	RW _{R1} Data	RW _{R1} Units
0, 5 <1>	–	OFF (output frequency)	output frequency	Set in the drives specified by o1-03 (Frequency Reference Setting Drives) in output frequency.
1, 2, 3, 4, 6, 7, 8	OFF (motor revolutions)	ON (motor revolutions)	motor revolutions	r/min
	ON (output frequency)	OFF (output frequency)	output frequency	Set in the drives specified by o1-03 (Frequency Reference Setting Drives) in output frequency.

<1> Controls in the same way as A1-02 = 1 (Control Method Selection = V/f Control w/ PG) in A1-02 = 0 (V/f Control) and H6-01 = 3 (PulseTrain InTerm RP Func Select = PG Feedback).

Table 20 RW_{R1} (Output Frequency) Units

Frequency Reference Setting and Display Drives (o1-03)	Frequency Reference Units (RW _{R1})
0	0.01 Hz units (output frequency)
1	0.01% units (percent of maximum output frequency)
2	min ⁻¹ (r/min) units (calculated from the maximum output frequency and the number of motor poles)
3	User-set (according to parameter o1-10 and o1-11)

Note: Refer to the instruction manual for the drive the CC-Link Option is connected to for more details on parameter settings.

■ **Energy-Saving Unit Remote Register**

PLC → Energy-Saving Unit

Table 21 Remote Register (PLC → Energy-Saving Unit)

Remote Register	Name	Description	Request Flag
RW _{W0}	Monitor Code	<ul style="list-style-type: none"> Sets the code number of the items to be displayed by the monitor. (Refer to <i>Energy-Saving Unit Monitor Codes on page 54</i>). Once the monitor code has been set, the monitor value is stored in register RWR0 by enabling RYC (the monitor execute request flag). While RW_{R0} is updated, RXC (during monitor flag) remains on. 	RYC (Monitor Execute Request)
RW _{W1}	Reserved	–	–
RW _{W2}	Command Code	<ul style="list-style-type: none"> Sets the command code to execute functions such as the fault reset, fault history, parameter read, and so on. (Refer to <i>Energy-Saving Unit Command Codes on page 52</i>, <i>Energy-Saving Unit Extended Command Codes on page 53</i>.) When RYF (command code execution request flag) is enabled, the energy-saving unit executes the specified command. Once the command has been carried out, RXF switches on. The value set to RWW3 (write data) should be adjusted accordingly to match changes to any parameter settings. 	RYF (Command Code Execute Request)
RW _{W3}	Write Data	<ul style="list-style-type: none"> Sets the value to be used along with RW_{W2} (Command Code) as needed. RYF (command code execution request flag) needs to be enabled after the command code and write data have been set. 	

Note: Use the extended command code 280H to set the DC bus voltage reference.

Energy-Saving Unit → PLC

Table 22 Remote Register (Energy-Saving Unit → PLC)

Remote Register	Name	Description	Check Flag
RW _{R0}	Monitor Data	<ul style="list-style-type: none"> Monitor data is stored according to RW_{W0} (Monitor Code). Monitor data is updated while RYC (monitor execute request flag) is enabled. RXC (during monitor) remains on as data is updated. 	RXC (while monitoring)
RW _{R1}	Reserved	–	–
RW _{R2}	Response Code	<ul style="list-style-type: none"> Sets 00H when there are no problems with RW_{W2} (Command Code) and RW_{W3} (Write Data). Sets 01H through 03H if an error occurs. Response Code: <ul style="list-style-type: none"> 00h: Normal 01h: Write-mode error (attempted to write during run, etc.) 02h: Command code error 03h: Data setting range error 	RXF (Command Code Execute Complete)
RW _{R3}	Read Data	Data is set according to the command code.	

Note: Use the monitor code 0008H to set the DC bus voltage feedback.

◆ Terminals that Change depending on the Model of the Drive

The table below lists terminals that change depending on the model of the drive.

Table 23 Terminals that Change depending on the Model of the Drive

Drive Type	Name	Terminal	Drive Model
YASKAWA AC Drive 1000-Series	Multi-Function Contact Output	M1-M2	All drives
	Multi-Function Photocoupler Output 1	P1-PC	CIMR-□A□, CIMR-□T□, CIMR-□K□, CIMR-□B□ <1>, CIMR-□D□
		M3-M4	CIMR-□U□, CIMR-□C□
	Multi-Function Photocoupler Output 2	P2-PC	CIMR-□A□, CIMR-□T□, CIMR-□K□, CIMR-□B□ <2>, CIMR-□D□
M5-M6		CIMR-□U□, CIMR-□C□	
YASKAWA AC Drive GA500	Multi-Function Digital Output 1	MA/ MB-MC	All drives
	Multi-Function Digital Output 2	P1-C1	All drives
	Multi-Function Digital Output 3	P2-C2	All drives
YASKAWA AC Drive GA700	Multi-Function Digital Output 1	M1-M2	All drives
	Multi-Function Digital Output 2	M3-M4	All drives
	Multi-Function Digital Output 3	P1-C1	CIPR-GA70A□, CIPR-GA70T□
		M5-M6	CIPR-GA70U□, CIPR-GA70C□, CIPR-GA70B□, CIPR-GA70K□, CIPR-GA70D□
Multi-Function Digital Output 4	P2-C2	CIPR-GA70A□, CIPR-GA70T□	
YASKAWA AC Drive GA800	Multi-Function Digital Output 1	M1-M2	All drives
	Multi-Function Digital Output 2	M3-M4	All drives
	Multi-Function Digital Output 3	M5-M6	All drives

<1> Terminals will change to M3-M4 depending on the model type of CIMR-□B□. Refer to the drive instruction manual for details.

<2> Terminals will change to M5-M6 depending on the model type of CIMR-□B□. Refer to the drive instruction manual for details.

9 Troubleshooting

◆ Drive-Side Error Codes

Drive-side error codes appear on the drive keypad. [Table 24](#) lists causes of the errors and possible corrective actions. Refer to the drive Technical Manual for additional error codes that may appear on the drive keypad.

■ Faults

Both bUS (Option Communication Error) and EF0 (Option Card External Fault) can appear as an alarm or as a fault. When a fault occurs, the keypad ALM LED remains. When an alarm occurs, the keypad ALM LED flashes.

If communication stops while the drive is running, answer the following questions to help remedy the fault:

- Is the option properly installed?
- Is the communication line properly connected to the option? Is it loose?
- Is the controller program working? Has the controller/PLC CPU stopped?
- Did a momentary power loss interrupt communications?

Table 24 Fault Display and Possible Solutions

Keypad Display		Fault Name
bUS	bUS	Option Communication Error
		<ul style="list-style-type: none"> • After establishing initial communication, the connection was lost. • Only detected when the run command or frequency reference is assigned to the option (b1-01 = 3 or b1-02 = 3).
Cause		Possible Solution
No signal was received from the PLC.		<ul style="list-style-type: none"> • Check for faulty wiring. • Correct any wiring problems.
Faulty communications wiring		
An existing short circuit or communications disconnection		Check disconnected cables and short circuits and repair as needed.
A data error occurred due to electric interference		<ul style="list-style-type: none"> • Counteract noise in the control circuit, main circuit, and ground wiring. • If a magnetic contactor is identified as a source of noise, install a surge absorber to the contactor coil. • Use only recommended cables or other shielded line. Ground the shield on the controller side or the drive input power side. • Separate all communication wiring from drive power lines. Install an EMC noise filter to the drive power supply input. • Counteract noise in the master controller (PLC).
The option is not properly connected to the drive.		Reinstall the option.
Option is damaged.		If there are no problems with the wiring and the error continues to occur, replace the option.
Keypad Display		Fault Name
EF0	EF0	Option Card External Fault
		The alarm function for an external device has been triggered.
Cause		Possible Solution
An external fault was received from the PLC.		<ol style="list-style-type: none"> 1. Remove the cause of the external fault. 2. Reset the external fault input from the PLC.
Problem with the PLC program		Check the PLC program.
Keypad Display		Fault Name
oFA00	oFA00	Option Card Connection Error (CN5-A)
		Option is not properly connected.
Cause		Possible Solution
The option card installed into port CN5-A is incompatible with the drive.		Connect the option to the correct option port. Note: PG option cards are supported by option ports CN5-B and CN5-C only.

Keypad Display		Fault Name
oFR01	oFA01	Option Card Fault (CN5-A)
		Option is not properly connected.
Cause		Possible Solution
The option connected to option port CN5-A was changed during run.		De-energize the drive and plug the option into the drive according to Installation Procedure on page 12 .
Keypad Display		Fault Name
oFR03, oFR04	oFA03, oFA04	Option Card Error (CN5-A)
		Option Card Error (CN5-A)
Cause		Possible Solution
A fault occurred in the option.		<ol style="list-style-type: none"> 1. De-energize the drive. 2. Make sure that the option is correctly connected to the connector. 3. If the problem continues, replace the option.
Keypad Display		Fault Name
oFR30 to oFR43	oFA30 to oFA43	Option Card Connection Error (CN5-A)
		Communication ID error.
Cause		Possible Solution
The option card connection to port CN5-A is faulty.		<ol style="list-style-type: none"> 1. Turn off the power. 2. Check if the option is properly plugged into the option port. 3. Replace the option if the fault continues to occur.
Keypad Display		Fault Name
oFb00	oFb00	Option Fault (CN5-B)
		Non-compatible option is connected.
Cause		Possible Solution
The option card installed into port CN5-A is incompatible with the drive.		<p>Connect the option to the correct option port.</p> <p>Note: Use connector CN5-B when connecting DO-A3, AO-A3, or two PG options. Use connector CN5-C when connecting only one PG option.</p>
Keypad Display		Fault Name
oFb02	oFb02	Option Fault (CN5-B)
		Two identical options are connected at the same time.
Cause		Possible Solution
An option of the same type is already installed in option port CN5-A, CN5-B, or CN5-C.		Connect the option to the correct option port.
Keypad Display		Fault Name
oFC00	oFC00	Option Fault (CN5-C)
		Non-compatible option is connected.
Cause		Possible Solution
The option card installed into port CN5-C is incompatible with the drive.		<p>Connect the option to the correct option port.</p> <p>Note: AI-A3, DI-A3, and communication options are not supported by option port CN5-C.</p>
Keypad Display		Fault Name
oFC02	oFC02	Option Fault
		Option Flash write mode.
Cause		Possible Solution
An option of the same type is already installed in option port CN5-A, CN5-B, or CN5-C.		Connect the option to the correct option port.

■ Alarms

Keypad Display		Alarm Name	
AEr	AEr	Station Address Error	
		Option is set to an address outside the allowable setting range.	
Cause		Possible Solution	Alarm (H2-□□ = 10)
CC-Link Option is set to an address outside the allowable setting range.		Set F6-10 to an address within the specified range.	YES
Keypad Display		Alarm Name	
CALL	CALL	Serial communication transmission error	
		Communication is not established.	
Cause		Possible Solution	Alarm (H2-□□ = 10)
Communication wiring is faulty.		<ul style="list-style-type: none"> • Check for wiring errors. • Correct the wiring. 	YES
An existing short circuit or communications disconnection		Check disconnected cables and short circuits and repair as needed.	
Programming error on the master side		Check communications at start-up and correct programming errors.	
Communication circuitry is damaged.		<ul style="list-style-type: none"> • Perform a self-diagnostics check. • If the problem continues, replace either the control board or the entire drive. For instructions on replacing the control board, contact Yaskawa or a Yaskawa representative. 	
Termination resistor of the MEMOBUS/Modbus communications is not enabled.		Set DIP switch S2 to the ON position to enable the termination resistor on a drive located at the end of a network line.	
Keypad Display		Alarm Name	
CyPo	CyPo	Cycle Power to Active Parameters	
		Comm. Option Parameter Not Upgraded	
Cause		Possible Solution	Alarm (H2-□□ = 10)
Although F6-15 = 1 [Comm. Option Parameters Reload = Reload Now], the drive did not update the communication option parameters.		Re-energize the drive to update the communication option parameters. Note: If the option software version is not compatible or if you install an incorrect option to the drive, it will trigger an alarm.	YES

◆ Fault LED Display on Option Side

■ Defining Option LED States

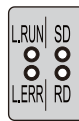

1000-Series Label

GA500, GA700, and GA800 Label

Figure 27 Option LED Labels

Table 25 LED Display

L.RUN	Switches on when data is being received normally. Turns off when the receive data is interrupted.
SD	Lights whenever data is sent.
RD	Light whenever data is received.
L.ERR	Lights when a CRC or abort error occurs.

Note: If communication stops while the drive is running, check the following:

- Is the option properly installed?
- Is the communication line properly connected to the option? Is it loose?
- Is the controller program working? Has the controller/PLC CPU stopped?
- Did a momentary power loss interrupt communications?

■ Faults that Occur with a Single Drive

The example below demonstrates how to read the LED display on the front cover of the drive to determine the cause of a fault and corrective action.

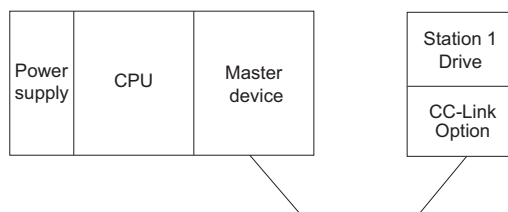

Figure 28 Connecting a Single Drive

Table 26 LED Fault Display for CC-Link Option with a Single Drive

○: On / □: Flashing / ×: Off / *: Either on or off

L.RUN	SD	RD	L.ERR	Cause	Possible Solution
○	○	○	×	Normal communications	–
○	○	○	□	Error has occurred but communication is normal.	⇒Remove the source of electrical noise interference.
○	○	×	□	Problem with the hardware	⇒Try cycling the power. Replace the CC-Link Option if the problem continues.
○	○	×	×	Problem with the hardware	⇒Try cycling the power. Replace the CC-Link Option if the problem continues.
○	×	○	□	CRC error with the data received, and no response can be sent	⇒Remove the source of electrical noise interference.
○	×	○	×	No station address received	⇒Check the PLC program and the operation where the problem occurred.
○	×	×	□	Problem with the hardware	⇒Try cycling the power. Replace the CC-Link Option if the problem continues.
○	×	×	×	Problem with the hardware	⇒Try cycling the power. Replace the CC-Link Option if the problem continues.
×	○	○	□	A response was received after polling, but a CRC error occurred when the reflex data was checked.	⇒Remove the source of electrical noise interference.
×	○	○	×	Problem with the hardware	⇒Try cycling the power. Replace the CC-Link Option if the problem continues. ⇒See if the master device is actually set to function as a remote device station.
×	○	×	□	Problem with the hardware	⇒Try cycling the power. Replace the CC-Link Option if the problem continues.
×	○	×	×	Problem with the hardware	⇒Try cycling the power. Replace the CC-Link Option if the problem continues.
×	×	○	□	CRC errors occurs when the station address is checked.	⇒Remove the source of electrical noise interference.
×	×	○	×	<ul style="list-style-type: none"> • No station address • Cannot receive station address due to electrical noise interference 	⇒Remove the source of electrical noise interference.
×	×	×	□	Problem with the hardware	⇒Try cycling the power. Replace the CC-Link Option if the problem continues.
×	×	×	×	Data cannot be received (CC-Link communications cable may be disconnected)	⇒Check the wiring.
×	×	*	○	The station address or communications speed is set incorrectly.	⇒Enter the proper settings and cycle power.
○	○	○	□	The station address or communications speed was changed without cycling power afterwards.	⇒Return any incorrect settings to their original values and cycle power. ⇒Enter the proper settings and cycle power.

Note: SD and RD may appear to flash with slower baud rates.

■ Faults when Running Multiple Drives

The example below demonstrates how to read the LED display on the front cover of the drive to determine the cause of a fault and the corrective action to take when multiple drives are running from the same network. The example assumes that SW, M/S, and PRM on the master device are all off, indicated that the master device is operating normally.

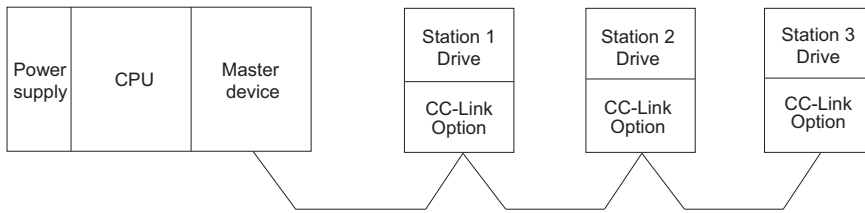

Figure 29 Connecting Multiple Drives on the Same Network

Table 27 LED Fault Display for CC-Link Option with Multiple Drives

○: On / □: Flashing / ×: Off / *: Either on or off

LED Status				Cause	Corrective Action
Master	Remote Device Addresses (CC-Link Option)				
	Station 1	Station 2	Station 3		
	L.RUN○ SD ○ RD ○ L.ERR ×	L.RUN○ SD ○ RD ○ L.ERR ×	L.RUN○ SD ○ RD ○ L.ERR ×	Normal operation	—
	L.RUN× SD × RD × L.ERR ×	L.RUN○ SD ○ RD ○ L.ERR ×	L.RUN○ SD ○ RD ○ L.ERR ×	The CC-Link Option for the first station is not properly installed.	⇒Make sure the CC-Link Option and drive are connected together properly.
	L.RUN* SD * RD * L.ERR *	L.RUN○ SD ○ RD ○ L.ERR ×	L.RUN○ SD ○ RD ○ L.ERR ×	The CC-Link Option for the first station is damaged (most often all LEDs are out). Note: Sometimes an error will appear on the drive's keypad	⇒Replace the CC-Link Option.
	L.RUN○ SD ○ RD ○ L.ERR ×	L.RUN× SD * RD * L.ERR ×	L.RUN× SD * RD * L.ERR ×	Because L.RUN after Station 2 is off, either the communication. line between Station 1 and Station 2 is disconnected, or the connector has come loose.	Make sure components are connected correctly, using the LEDs as a guide to indicate a proper connection.
TIME ○ LINE ○ or TIME × LINE ○	L.RUN× SD * RD * L.ERR ×	L.RUN× SD * RD * L.ERR ×	L.RUN× SD * RD * L.ERR ×	Communication cable has short-circuited	⇒Look for any short-circuits along the communication lines and fix any problems.
	L.RUN× SD * RD * L.ERR *	L.RUN× SD * RD * L.ERR *	L.RUN× SD * RD * L.ERR *	Communication cable is not wire properly	⇒Check the wiring for the CC-Link Option connector and fix and mistakes.
	L.RUN× SD * RD ○ L.ERR ×	L.RUN○ SD ○ RD ○ L.ERR ×	L.RUN× SD * RD ○ L.ERR ×	The CC-Link Options for Station 1 and Station 3 have been assigned the same address.	⇒Enter the correct station address and cycle power.
	L.RUN○ SD ○ RD ○ L.ERR ×	L.RUN× SD × RD ○ L.ERR ×	L.RUN○ SD ○ RD ○ L.ERR ×	The CC-Link Option for Station 2 has a different communication speed setting than the master device.	⇒Set the correct communication speed and cycle power.
	L.RUN○ SD ○ RD ○ L.ERR ×	L.RUN○ SD ○ RD ○ L.ERR ×	L.RUN○ SD ○ RD ○ L.ERR □	The settings for the CC-Link Option connected to Station 3 were changed without cycling power.	⇒Return any incorrect settings to their original values and cycle power. ⇒Enter the proper settings and cycle power.
	L.RUN× SD × RD ○ L.ERR ○	L.RUN○ SD ○ RD ○ L.ERR ×	L.RUN○ SD ○ RD ○ L.ERR ×	Parameters related to the CC-Link Option (F6-10, F6-11) for Station 1 are set outside the acceptable range.	⇒ Set F6-10 and F6-11 correctly and cycle power.

○: On / □: Flashing / ×: Off / *: Either on or off

LED Status				Cause	Corrective Action
Master	Remote Device Addresses (CC-Link Option)				
	Station 1	Station 2	Station 3		
	L.RUN ○ SD ○ RD ○ L.ERR ×	L.RUN ○ SD ○ RD ○ L.ERR ○	L.RUN ○ SD ○ RD ○ L.ERR ×	The CC-Link Option connected to Station 2 is experiencing electrical noise interference (L.RUN is sometimes off).	⇒Make sure that the CC-Link Options, drives, and master device are all grounded properly.
TIME × LINE × or TIME ○ LINE ×	L.RUN ○ SD ○ RD ○ L.ERR ×	L.RUN ○ SD ○ RD ○ L.ERR ○	L.RUN ○ SD ○ RD ○ L.ERR ○	Electrical noise interference along the cable running between Station 2 and Station 3 (L.RUN is sometimes off).	⇒Reconnect the communication line to the SLD terminal on the CC-Link Option connector. Also make sure that all power cables are properly separated from communication lines (at least 100 mm away).
	L.RUN ○ SD ○ RD ○ L.ERR ×	L.RUN ○ SD ○ RD ○ L.ERR ×	L.RUN ○ SD ○ RD ○ L.ERR ○	Termination resistor not connected (L.RUN is sometimes off).	⇒Configure the final station in the series with a termination resistor.

10 CC-Link Code Numbers

Note: Command codes, extended command codes, monitor codes, fault contents, and alarm contents vary between drives and energy-saving units.

◆ Drive Codes

■ Drive Command Codes

Table 28 Drive Command Codes

Command Code	Name	Description
1181H	Read Run command source	0: Keypad 1: Control circuit terminals (sequencer input) 2: MEMOBUS/Modbus communications 3: Option card
1180H	Read frequency reference source	0: Keypad 1: Control circuit terminals (analog input) 2: MEMOBUS/Modbus communications 3: Option card 4: Pulse train input
2181H	Write Run command source	0: Keypad 1: Control circuit terminals (sequencer input) 2: MEMOBUS/Modbus communications 3: Option card
2180H	Write frequency reference source	0: Keypad 1: Control circuit terminals (analog input) 2: MEMOBUS/Modbus communications 3: Option card 4: Pulse train input
0074H	Fault History 1	Reads the contents from U3-01.
0075H	Fault History 2	Reads the contents from U3-02.
0076H	Fault History 3	Reads the contents from U3-03.
0077H	Fault History 4	Reads the contents from U3-04.
0078H	Fault History 5	Reads the contents from U3-05.
0079H	Fault History 6	Reads the contents from U3-06.
007AH	Fault History 7	Reads the contents from U3-07.
0080H	Fault History 8	Reads the contents from U3-08.
0081H	Fault History 9	Reads the contents from U3-09.
0082H	Fault History 10	Reads the contents from U3-10.
006DH	Read frequency reference (RAM)	Reads the drive's frequency reference from RAM.
006EH	Read frequency reference (EEPROM)	Reads the frequency reference from EEPROM.
007BH	Read LOCAL/REMOTE status	0: 0 = Frequency reference is supplied by CC-Link. 1: 0 = FWD/REV Run command is supplied by CC-Link. 8: 1 = During Stall Prevention.
00FBH	Write LOCAL/REMOTE status	0: 0 = Frequency reference from CC-Link is enabled. 1: 0 = FWD/REV Run command from CC-Link is enabled. When power is cycled, however, the source is determined by parameters b1-01 and b1-02. If one of the multi-function relay input terminals is set to switch the source of the Run command (H1-□□ = 2), then the Run command and frequency reference will be supplied by parameters b1-15 and b1-16 when that terminal is closed.
00EDH	Write frequency reference (RAM)	Writes the frequency reference for the drive to RAM.
00EEH	Write frequency reference (EEPROM)	Writes the frequency reference and all parameter values to EEPROM.
–	Read parameters	Adds 1000H to the MEMOBUS/Modbus register number.
–	Parameter settings	Master executes commands by adding 2000H to the MEMOBUS/Modbus register number. Conversion takes place on the option card side.
00F4H	Clear all fault contents	9696H: Clear fault history
00FDH	Reset drive	9696H: Fault reset

■ Drive Extended Command Codes

Table 29 Drive Extended Command Codes

Command Code		Name	
Read	Write	BIT	
100H	-	Operation signals	
		0	H5-12 = 0: Forward run command (0 = Stop, 1 = Forward run) H5-12 = 1: Run command (0 = Stop, 1 = Run)
		1	H5-12 = 0: Reverse run command (0 = Stop, 1 = Reverse run) H5-12 = 1: Forward/Reverse (0 = Forward, 1 = Reverse)
		2	External fault (EF0)
		3	Fault reset
		4	Multi-function input 1 Bit disabled when H1-01 = 40 (FWD/Stop)
		5	Multi-function input 2 Bit disabled when H1-02 = 41 (REV/Stop)
		6	Multi-function input 3
		7	Multi-function input 4
		8	Multi-function input 5
		9	Multi-function input 6
		A	Multi-function input 7
		B	Multi-function input 8
		C to F	Reserved
101H	-	Frequency reference (RAM)	
102H	202H	Torque reference / torque limit	
103H	203H	Torque compensation	
104H	204H	PID setpoint	
105H	205H	Multi-function analog monitor output terminal 1	
106H	206H	Multi-function analog monitor output terminal 2	
107H	207H	Multi-function relay output <I>	
		0	<ul style="list-style-type: none"> YASKAWA AC Drive 1000-Series Multi-Function Contact Outputs (terminal M1-M2) 1: ON 0: OFF YASKAWA AC Drive GA500 Multi-Function Contact Outputs (terminal MA/MB-MC) 1: ON 0: OFF YASKAWA AC Drive GA700 and GA800 Multi-function digital output 1 (terminal M1-M2) 1: ON 0: OFF
		1	<ul style="list-style-type: none"> YASKAWA AC Drive 1000-Series Multi-Function Photocoupler Output 1 (terminal P1-PC) <I> 1: ON 0: OFF YASKAWA AC Drive GA500 Multi-Function Photocoupler Output 1 (terminal P1-C1) 1: ON 0: OFF YASKAWA AC Drive GA700 and GA800 Multi-function digital output 2 (terminal M3-M4) 1: ON 0: OFF
		2	<ul style="list-style-type: none"> YASKAWA AC Drive 1000-Series Multi-Function Photocoupler Output 2 (terminal P2-PC) <I> 1: ON 0: OFF YASKAWA AC Drive GA500 Multi-Function Photocoupler Output 2 (terminal P2-C2) 1: ON 0: OFF YASKAWA AC Drive GA700 and GA800 Multi-function digital output 3 <I> 1: ON 0: OFF
		3	<ul style="list-style-type: none"> YASKAWA AC Drive 1000-Series, GA500 Reserved YASKAWA AC Drive GA700 and GA800 Multi-function digital output 4 <I> 1: ON 0: OFF
		4-5	Reserved
		6	1 : Bit 7 function enabled
		7	1 : Fault Contact Output (terminal MA/MB-MC) 1: ON 0: OFF
		8 to F	Reserved
		109H	209H
10FH	20FH	V/f gain	

10 CC-Link Code Numbers

Command Code		Name	
Read	Write	BIT	
110H	-	Status signal	
		0	During run
		1	During zero speed
		2	During reverse
		3	During fault reset signal input
		4	During speed agree
		5	Drive Ready
		6	Alarm
		7	Fault
		8	During operation error (oPE□□)
		9	During Momentary power loss
		A	NetCtrl status
		B	<ul style="list-style-type: none"> • YASKAWA AC Drive 1000-Series Contact output (terminal M1-M2) 1: ON 0: OFF • YASKAWA AC Drive GA500 Contact output (terminal MA/MB-MC) 1: ON 0: OFF • YASKAWA AC Drive GA700 and GA800 Multi-function digital output 1 (terminal M1-M2) 1: ON 0: OFF
		C	<ul style="list-style-type: none"> • YASKAWA AC Drive 1000-Series Multi-Function Photocoupler Output 1 (terminal P1-PC) <2> 1: ON 0: OFF • YASKAWA AC Drive GA500 Multi-Function Photocoupler Output 1 (terminal P1-C1) 1: ON 0: OFF • YASKAWA AC Drive GA700 and GA800 Multi-function digital output 2 (terminal M3-M4) 1: ON 0: OFF
D	<ul style="list-style-type: none"> • YASKAWA AC Drive 1000-Series Multi-Function Photocoupler Output 2 (terminal P2-PC) <2> 1: ON 0: OFF • YASKAWA AC Drive GA500 Multi-Function Photocoupler Output 2 (terminal P2-C2) 1: ON 0: OFF • YASKAWA AC Drive GA700 and GA800 Multi-function digital output 3 <2> 1: ON 0: OFF 		
E	Motor 2 selected		
F	Zero servo complete		
111H	-	Motor speed (r/min)	
112H	-	Through-mode	
113H	-	Number of pulse 1 speed detection	
114H	-	Frequency reference	
115H	-	Output frequency	
116H	-	Output current	
117H	-	Analog input terminal A1	
118H	-	DC bus voltage	
11CH	-	Analog input terminal A2	
11DH	-	Sequence input	
11EH	-	Analog input terminal A3	
11FH	-	Number of pulse 2 speed detection	
120H	-	Fault contents 1 <3>	
121H	-	Fault contents 2 <3>	
122H	-	Fault contents 3 <3>	
123H	-	Fault contents 4 <3>	
124H	-	Fault contents 5 <3>	
130H	-	CPF contents 1 <3>	
131H	-	CPF contents 2 <3>	
132H	-	CPF contents 3 <3>	

<1> When using YASKAWA AC Drive GA700 and GA800, refer to command data 0009H of the MEMOBUS/Modbus data table in the drive instruction manual for information on bit assignment.

<2> Terminals will differ depending on the model of the drive. Refer to [Terminals that Change depending on the Model of the Drive on page 37](#) for information on terminals.

<3> Refer to [Drive Fault Contents on page 48](#) or [Drive Alarm Contents on page 51](#) for information on fault contents.

■ Drive Monitor Codes

Table 30 Drive Monitor Codes

Monitor Code	Name	Comments
0000H	Reserved	—
0001H	Output frequency	Units are determined by o1-03.
0002H	Output current	Units are either 0.1 A or 0.01 A, depending on the capacity of the drive.
0003H	Output voltage reference	Units: 0.1 V
0004H	Reserved	—
0005H	Frequency reference	Units are determined by o1-03.
0006H	Motor speed	Units: 1 r/min
0007H	Motor torque	Units: 0.1%
0008H	DC bus voltage	Units: 1 V
0009H to 000DH	Reserved	—
000EH	Output power	Units: 1 V
000FH	Input terminal status	<p>7 6 5 4 3 2 1 0 RW 1: ON 0: OFF</p> <ul style="list-style-type: none"> Multi-Function Digital Input 1 (terminal S1 enabled) Multi-Function Digital Input 2 (terminal S2 enabled) Multi-Function Digital Input 3 (terminal S3 enabled) Multi-Function Digital Input 4 (terminal S4 enabled) Multi-Function Digital Input 5 (terminal S5 enabled) Multi-Function Digital Input 6 (terminal S6 enabled) Multi-Function Digital Input 7 (terminal S7 enabled) Multi-Function Digital Input 8 (terminal S8 enabled)
0010H	Output terminal status	<ul style="list-style-type: none"> • When using YASKAWA AC Drive 1000-Series <p>7 6 5 4 3 2 1 0 RW 1: ON 0: OFF</p> <ul style="list-style-type: none"> Multi-Function Digital Output (terminal M1-M2) enabled Multi-Function Digital Output 1 (terminal P1) enabled </I> Multi-Function Digital Output 2 (terminal P2) enabled </I> Fault Contact Output (terminal MA/MB-MC) enabled • When using YASKAWA AC Drive GA500 <p>7 6 5 4 3 2 1 0 RW 1: ON 0: OFF</p> <ul style="list-style-type: none"> Multi-Function Digital Output (terminal MA/MB-MC) enabled Multi-Function Digital Output 1 (terminal P1-C1) enabled Multi-Function Digital Output 2 (terminal P2-C2) enabled • When using YASKAWA AC Drive GA700 and GA800 <p>7 6 5 4 3 2 1 0 RW 1: ON 0: OFF</p> <ul style="list-style-type: none"> Multi-function digital output 1 (terminal M1-M2) enabled Multi-function digital output 2 (terminal M3-M4) enabled Multi-function digital output 3 enabled </I> Fault Contact Output (terminal MA/MB-MC) enabled
0011H	Reserved	—
0012H	Motor excitation current	Units: 0.1%
0013H	Reserved	—
0014H	Cumulative operation time	<ul style="list-style-type: none"> • Units: 1 hour • Parameter o4-02 determines if the operation time is the considered to be whenever the drive powered on or only when there is voltage output.
0015H, 0016H	Reserved	—
0017H	Actual operation time	<ul style="list-style-type: none"> • Units: 1 hour • Parameter o4-02 determines if the operation time is the considered to be whenever the drive powered on or only when there is voltage output.
0018H	Motor secondary current	—

10 CC-Link Code Numbers

Monitor Code	Name	Comments
0019H	Cumulative power	Units: 4 kW
0034H	PID setpoint	Units: 0.1%
0035H	PID input	Units: 0.1%
0036H	PID output	Units: 0.1%
1000H	Number of pulse 1 speed detection	—
1001H	Number of pulse 2 speed detection	—
1002H	Cumulative operation time	—
1003H	Watt-hour output (lower digits)	—
1004H	Watt-hour output (upper digits)	—
1010H	Alarm code	—
1011H	Fault code	—
1012H	Reserved	—
1013H	Fault contents 1 <2>	—
1014H	Fault contents 2 <2>	—
1015H	Fault contents 3 <2>	—
1016H	Fault contents 4 <2>	—
1017H	Fault contents 5 <2>	—
101CH	CPF contents 1 <2>	—
101DH	CPF contents 2 <2>	—
101EH	CPF contents 3 <2>	—
101FH	Alarm contents 1 <2>	—
1020H	Alarm contents 2 <2>	—
1021H	Alarm contents 3 <2>	—
1022H	Alarm contents 4 <2>	—
1023H	Alarm contents 5 <2>	—
1027H	Output frequency at previous fault	—
1028H	Output frequency at previous fault	—
1029H	Output voltage at previous fault	—
102AH	Total operation time at previous fault	—

<1> Terminals will differ depending on the model of the drive. Refer to [Terminals that Change depending on the Model of the Drive on page 37](#) for information on terminals.

<2> Refer to [Drive Fault Contents on page 48](#) or [Drive Alarm Contents on page 51](#) for information on fault contents.

■ Drive Fault Contents

Table 31 Drive Fault Contents

Extended Command Code (Monitor Code)	Fault Name		Fault Code (U2, U3)
	BIT		
120H (1013H)	Fault contents 1		—
	0	Reserved	—
	1	Undervoltage (Uv1)	0002H
	2	Control power supply undervoltage (Uv2)	0003H
	3	Softcharge circuit fault (Uv3)	0004H
	4	Load short-circuit (SC)	0005H
	5	Reserved	—
	6	Overcurrent (oC)	0007H
	7	Overvoltage (ov)	0008H
	8	Heatsink overheat (oH)	0009H
	9	Heatsink overheat (oH1)	000AH
	A	Motor overload (oL1)	000BH
	B	Drive overload (oL2)	000CH
	C	Overtorque detection 1 (oL3)	000DH
	D	Overtorque detection 2 (oL4)	000EH
E	Dynamic braking transistor (rr)	000FH	
F	Braking resistor overheat (rH)	0010H	

Extended Command Code (Monitor Code)	Fault Name		Fault Code (U2, U3)
	BIT		
121H (1014H)	Fault contents 2		–
	0	External fault (input terminal S3) (EF3)	0011H
	1	External fault (input terminal S4) (EF4)	0012H
	2	External fault (input terminal S5) (EF5)	0013H
	3	External fault (input terminal S6) (EF6)	0014H
	4	External fault (input terminal S7) (EF7)	0015H
	5	External fault (input terminal S8) (EF8)	0016H
	6	Reserved	–
	7	Overspeed (oS) Note: Possible only when using Simple V/f with PG	0018H
	8	Excessive speed deviation (dEv) Note: Possible only when using Simple V/f with PG	0019H
	9	PG disconnect (PGo) Note: Possible only when using Simple V/f with PG	001AH
	A	Input phase loss (PF)	001BH
	B	Output phase loss (LF)	001CH
	C	Motor overheat (PTC input) (oH3)	001DH
	D	Keypad connection fault (oPr)	001EH
	E	EEPROM write error (Err)	001FH
F	Motor overheat fault (PTC input) (oH4)	0020H	
122H (1015H)	Fault contents 3		–
	0	MEMOBUS/Modbus communication fault (CE)	0021H
	1	Option communications error (bUS)	0022H
	2, 3	Reserved	–
	4	Control fault (CF)	0025H
	5	Zero servo fault (SvE)	0026H
	6	Option card external fault (EF0)	0027H
	7	PID feedback loss (FbL)	0028H
	8, 9	Undertorque detection 1 (UL3)	0029H
	A	High Slip Braking overload (oL7)	002BH
	B to E	Reserved	–
	F	Hardware fault (including oF□)	0030H
123H (1016H)	Fault contents 4		–
	0	Reserved	–
	1	Z-phase pulse fall detection (Only IPM mode with PG)	0032H
	2	Z-phase noise fault detection (Only IPM mode with PG)	0033H
	3	Inversion detection (Only IPM mode with PG)	0034H
	4	Inversion prevention detection (Only IPM mode with PG)	0035H
	5	Output current imbalance (LF2)	0036H
	6	Pullout detection (STo) Note: When using YASKAWA AC Drive GA500, GA700 and GA800, “STPo” (Motor Pull Out or Step Out Detection) will be displayed.	0037H
	7	PG fault (PGoH)	–
	8, 9	Reserved	–
	A	Too many speed search restart (SEr)	003BH
	B to F	Reserved	–

10 CC-Link Code Numbers

Extended Command Code (Monitor Code)	Fault Name		Fault Code (U2, U3)
	BIT		
124H (1017H)	Fault contents 5		–
	0	Excessive PID feedback (FbH)	0041H
	1	External fault (input terminal S1) (EF1)	0042H
	2	External fault (input terminal S2) (EF2)	0043H
	3	Mechanical weakening detection 1 (oL5)	0044H
	4	Mechanical weakening detection 2 (UL5)	0045H
	5	Current offset fault (CoF)	0046H
	6, 7	Reserved	–
	8	DriveWorksEZ fault (dWFL)	0049H
	9 to B	Reserved	–
	C	Output Voltage Detection Fault (voF)	–
	D	Braking Resistor Fault (rF)	–
	E	Braking Transistor Overload Fault (boL)	–
	F	Reserved	–
130H (101CH)	CPF contents 1		–
	0, 1	Reserved	–
	2	A/D conversion error (CPF02)	0083H
	3	PWM data error (CPF03)	0084H
	4, 5	Reserved	–
	6	EEPROM data error (CPF06)	0087H
	7	Terminal board communication error (CPF07)	0088H
	8	EEPROM serial communication fault (CPF08)	0089H
	9, A	Reserved	–
	B	RAM fault (CPF11)	008CH
	C	Flash memory fault (CPF12)	008DH
	D	Watchdog circuit exception (CPF13)	008EH
	E	Control circuit fault (CPF14)	008FH
	F	Reserved	–
131H (101DH)	CPF contents 2		–
	0	Clock fault (CPF16)	0091H
	1	Timing fault (CPF17)	0092H
	2	Control circuit fault (CPF18)	0093H
	3	Control circuit fault (CPF19)	0094H
	4	Hardware fault at power up (CPF20)	0095H
	5	Hardware fault at communication start up (CPF21)	0096H
	6	A/D conversion fault (CPF22)	0097H
	7	PWM feedback fault (CPF23)	0098H
	8	Drive capacity signal fault (CPF24)	0099H
	9	Reserved	–
	A	Control Circuit Fault (CPF26)	009BH
	B	Control Circuit Fault (CPF27)	009CH
	C	Control Circuit Fault (CPF28)	009DH
	D	Control Circuit Fault (CPF29)	009EH
	E	Control Circuit Fault (CPF30)	009FH
	F	Control Circuit Fault (CPF31)	00A0H
132H (101EH)	CPF contents 3		–
	0	CPF32 Control Circuit Fault	00A1H
	1	CPF33 Control Circuit Fault	00A2H
	2	CPF34 Control Circuit Fault	00A3H
	3 to F	Reserved	–

■ Drive Alarm Contents

Table 32 Drive Alarm Contents

Monitor Code	Alarm Name		Alarm Code (MEMOBUS/ Modbus Register 07FH)
	BIT		
101FH	Alarm contents 1		–
	0	Undervoltage (Uv)	0001H
	1	Overvoltage (ov)	0002H
	2	Heatsink Overheat (oH)	0003H
	3	Drive Overheat (oH2)	0004H
	4	Overtorque 1 (oL3)	0005H
	5	Overtorque 2 (oL4)	0006H
	6	Run Command Input Error (EF)	0007H
	7	Drive Baseblock (bb)	0008H
	8	External Fault (input terminal S3) (EF3)	0009H
	9	External Fault (input terminal S4) (EF4)	000AH
	A	External Fault (input terminal S5) (EF5)	000BH
	B	External Fault (input terminal S6) (EF6)	000CH
	C	External Fault (input terminal S7) (EF7)	000DH
	D	External Fault (input terminal S8) (EF8)	000EH
	E	Reserved	–
F	Overspeed (oS)	0010H	
1020H	Alarm contents 2		–
	0	Excessive Speed Deviation (dEv)	0011H
	1	PG Disconnect (PGo)	0012H
	2	Keypad Connection Fault (oPr)	0013H
	3	MEMOBUS/Modbus Communication Error (CE)	0014H
	4	Option Card Communications Error (bUS)	0015H
	5	Serial Communication Transmission Error (CALL)	0016H
	6	Motor Overload (oL1)	0017H
	7	Drive Overload (oL2)	0018H
	8	Reserved	–
	9	Option Card External Fault (EF0)	001AH
	A	During Run 2, Motor Switch Command Input (rUn)	001BH
	B	Reserved	–
	C	Serial Communication Transmission Error (CALL)	001DH
	D	Undertorque Detection 1 (UL3)	001EH
	E	Undertorque Detection 2 (UL4)	001FH
F	MEMOBUS/Modbus Test Mode Fault (SE)	0020H	
1021H	Alarm contents 3		–
	0	Reserved	–
	1	Motor Overheat (oH3)	0022H
	2 to 5	Reserved	–
	6	PID Feedback Loss (FbL)	0027H
	7	Excessive PID Feedback (FbH)	0028H
	8	Reserved	–
	9	Drive Disabled (dnE)	002AH
	A	PG Hardware Fault (PGoH)	002BH
B to F	Reserved	–	

10 CC-Link Code Numbers

Monitor Code	Alarm Name		Alarm Code (MEMOBUS/ Modbus Register 07FH)
	BIT		
1022H	Alarm contents 4		–
	0	Reserved	–
	1	Station Number Setting Error (AEr)	0032H
	2	Reserved	–
	3	Current Alarm (HCA)	0034H
	4	Cooling Fan Maintenance Time (LT-1)	0035H
	5	Capacitor Maintenance Time (LT-2)	0036H
	6, 7	Reserved	–
	8	External Fault (input terminal S1) (EF1)	0039H
	9	External Fault (input terminal S2) (EF2)	003AH
	A	Safe Disable Signal Input (HbbF)	003BH
	B	Safe Disable Signal Input (Hbb)	003CH
	C	Mechanical Weakening Detection 1 (oL5)	003DH
	D	Mechanical Weakening Detection 2 (UL5)	003EH
E, F	Reserved	–	
1023H	Alarm contents 5		–
	0	Output Voltage Detection Fault (voF)	0041H
	1	IGBT Maintenance Time (90%) (TrPC)	0042H
	2	Soft Charge Bypass Relay Maintenance Time (LT-3)	0043H
	3	IGBT Maintenance Time (50%) (LT-4)	0044H
	4	Braking Transistor Overload Fault (boL)	0045H
	5, 6	Reserved	–
	7	Reserved	–
	8	DriveWorksEZ Alarm (dWAL)	0049H
	9 to F	Reserved	–

◆ Energy-Saving Unit Codes

■ Energy-Saving Unit Command Codes

Table 33 Energy-Saving Unit Command Codes

Command Code	Name	Description
0074H	Fault History 1	Reads the contents from U3-01.
0075H	Fault History 2	Reads the contents from U3-02.
0076H	Fault History 3	Reads the contents from U3-03.
0077H	Fault History 4	Reads the contents from U3-04.
0078H	Fault History 5	Reads the contents from U3-05.
0079H	Fault History 6	Reads the contents from U3-06.
007AH	Fault History 7	Reads the contents from U3-07.
0080H	Fault History 8	Reads the contents from U3-08.
0081H	Fault History 9	Reads the contents from U3-09.
0082H	Fault History 10	Reads the contents from U3-10.
007BH	Read LOCAL/REMOTE status	0: 0 = Frequency reference is supplied by CC-Link. 1: 0 = FWD/REV Run command is supplied by CC-Link.
00FBH	Write LOCAL/REMOTE status	0: 0 = Frequency reference from CC-Link is enabled. 1: 0 = FWD/REV Run command from CC-Link is enabled. When power is cycled, however, the source is determined by parameters b1-01 and b1-02.
–	Read parameters	Adds 1000H to the MEMOBUS/Modbus register number.
–	Parameter settings	Master executes commands by adding 2000H to the MEMOBUS/Modbus register number. Conversion takes place on the option card side.
00F4H	Clear all fault contents	9696H: Clear fault history
00FDH	Reset converter	9696H: Fault reset

■ Energy-Saving Unit Extended Command Codes

Table 34 Energy-Saving Unit Extended Command Codes

Command Code		Name	
Read	Write	BIT	
100H	-	Operation signals	
		0	Run Command <I>/Automatic Run Command, Stop Command <I>
		1	Forced Run command, Stop Command
		2	External fault (EF0)
		3	Fault reset
		4	Multi-function input 1
		5	Multi-function input 2
		6	Multi-function input 3
		7	Multi-function input 4
		8	Multi-function input 5
		9	Multi-function input 6
		A	Multi-function input 7
		B	Multi-function input 8
		C to F	Reserved
105H	205H	Multi-function analog monitor output terminal 1	
106H	206H	Multi-function analog monitor output terminal 2	
107H	-	Multi-function relay output	
		0	Multi-Function Contact Outputs (terminal M1-M2) 1: ON 0: OFF
		1	Multi-Function Photocoupler Output 1 (terminal P1-PC) <2> 1: ON 0: OFF
		2	Multi-Function Photocoupler Output 2 (terminal P2-PC) <2> 1: ON 0: OFF
		3-5	Reserved
		6	1 : Bit 7 function enabled
		7	1 : Fault Contact Output (terminal MA/MB-MC) 1 : ON 0 : OFF
8-F	Reserved		
110H	-	Status signal	
		0	1: During Run 0: During Stop
		1	Reserved
		2	1: During Regenerative Operation
		3	1: During Reset Signal Input
		4	1: During run (Operation Ready)
		5	1: Operation Ready
		6	1: Alarm
		7	1: Fault
		8	1: oPE Error
		9	1: Momentary Power Loss Ridethru 0: Recovery from Momentary Power Loss
		A	1: ComCtrl status/NetCtrl status
		B, C	Reserved
		D	1: During Active Current Limit
E, F	Reserved		
117H	-	Analog input terminal A1	
11CH	-	Analog input terminal A2	
11EH	-	Analog input terminal A3	
120H	-	Fault contents 1 <I>	
121H	-	Fault contents 2 <I>	
122H	-	Fault contents 3 <I>	
123H	-	Fault contents 4 <I>	
124H	-	Fault contents 5 <I>	
125H	-	Fault contents 6 <I>	
126H	-	Fault contents 7 <I>	
130H	-	CPF contents 1 <I>	
131H	-	CPF contents 2 <I>	

10 CC-Link Code Numbers

Command Code		Name
Read	Write	
132H	–	CPF contents 3 <1>
160H	–	DC bus voltage feedback
161H	–	DC voltage reference
162H	–	DC current reference
163H	–	Power supply side power
164H	–	Power supply side current
–	280H	DC bus voltage reference
–	281H	Active current limit (positive)
–	282H	Active current limit (negative)
1181H	2181H	Read and write Run command source 0: LED keypad 1: Control circuit terminals (sequencer input) 2: MEMOBUS/Modbus communications 3: Option card
1179H	2179H	Read and write voltage reference source 0: Keypad 1: Control circuit terminals (analog input) 2: MEMOBUS/Modbus communications 3: Option PCB 7: Input voltage based control 1 8: Input voltage based control 2

<1> Refer to *Energy-Saving Unit Fault Contents on page 55* or *Energy-Saving Unit Alarm Contents on page 58* for information on fault contents.
 <2> Terminals will differ depending on the model of the drive. Refer to *Terminals that Change depending on the Model of the Drive on page 37* for information on terminals.

■ Energy-Saving Unit Monitor Codes

Table 35 Energy-Saving Unit Monitor Codes

Monitor Code	Name	Comments
0000H to 0006H	Reserved	–
0007H	DC bus voltage reference (before SFS)	Units: 1 V
0008H	DC bus voltage feedback	Units: 1 V
0009H to 000CH	Reserved	–
000DH	Power supply side power	Units: 1 kW
000EH	DC bus side power	Units: 1 kW
000FH	Input terminal status	<p>7 6 5 4 3 2 1 0 RW 1: ON 0: OFF</p> <ul style="list-style-type: none"> Multi-Function Digital Input 1 (terminal S1 enabled) Multi-Function Digital Input 2 (terminal S2 enabled) Multi-Function Digital Input 3 (terminal S3 enabled) Multi-Function Digital Input 4 (terminal S4 enabled) Multi-Function Digital Input 5 (terminal S5 enabled) Multi-Function Digital Input 6 (terminal S6 enabled) Multi-Function Digital Input 7 (terminal S7 enabled) Multi-Function Digital Input 8 (terminal S8 enabled)
0010H	Output terminal status	<p>7 6 5 4 3 2 1 0 RW 1: ON 0: OFF</p> <ul style="list-style-type: none"> Multi-Function Digital Output (terminal M1-M2) enabled Multi-Function Digital Output 1 (terminal P1) enabled <1> Multi-Function Digital Output 2 (terminal P2) enabled <1> Fault Contact Output (terminal MA/MB-MC) enabled
0011H to 0017H	Reserved	–
0018H	Active current	Units: 0.1%
0019H	Reserved	–
0034H to 0036H	Reserved	–

Monitor Code	Name	Comments
1000H, 1001H	Reserved	–
1002H	Power supply side voltage	–
1003H	Power supply side current	–
1004H	DC bus side current	–
1010H	Alarm code	–
1011H	Fault codes	–
1012H	Reserved	–
1013H	Fault contents 1 <2>	–
1014H	Fault contents 2 <2>	–
1015H	Fault contents 3 <2>	–
1016H	Fault contents 4 <2>	–
1017H	Fault contents 5 <2>	–
1018H	Fault contents 6 <2>	–
1019H	Fault contents 7 <2>	–
101CH	CPF contents 1 <2>	–
101DH	CPF contents 2 <2>	–
101EH	CPF contents 3 <2>	–
101FH	Alarm contents 1 <2>	–
1020H	Alarm contents 2 <2>	–
1021H	Alarm contents 3 <2>	–
1022H	Alarm contents 4 <2>	–
1023H	Alarm contents 5 <2>	–
1027H	Reserved	–
1028H	Power supply side current at previous fault	–
1029H	DC bus voltage feedback at previous fault	–
102AH	Cumulative operation time at previous fault	–

<1> Terminals will differ depending on the model of the drive. Refer to *Terminals that Change depending on the Model of the Drive on page 37* for information on terminals.

<2> Refer to *Energy-Saving Unit Fault Contents on page 55* or *Energy-Saving Unit Alarm Contents on page 58* for information on fault contents.

■ Energy-Saving Unit Fault Contents

Table 36 Energy-Saving Unit Fault Contents

Extended Command Code (Monitor Code)	Fault Name		Fault Code (U2, U3)
	BIT		
120H (1013H)	Fault contents 1		–
	0	DC fuse blowout (FUd)	0001H
	1	Undervoltage (Uv1)	0002H
	2	Control power supply undervoltage (Uv2)	0003H
	3	Softcharge circuit fault (Uv3)	0004H
	4	Load short-circuit (SC)	0005H
	5	Ground fault (GF)	0006H
	6	Overcurrent (oC)	0007H
	7	Overvoltage (ov)	0008H
	8	Heatsink overheat (oH)	0009H
	9	Heatsink overheat (oH1)	000AH
	A	Reserved	–
	B	Converter overload (oL2)	000CH
C to F	Reserved	–	

10 CC-Link Code Numbers

Extended Command Code (Monitor Code)	Fault Name		Fault Code (U2, U3)
	BIT		
121H (1014H)	Fault contents 2		–
	0	External fault (input terminal S3) (EF3)	0011H
	1	External fault (input terminal S4) (EF4)	0012H
	2	External fault (input terminal S5) (EF5)	0013H
	3	External fault (input terminal S6) (EF6)	0014H
	4	External fault (input terminal S7) (EF7)	0015H
	5	External fault (input terminal S8) (EF8)	0016H
	6	Cooling fan error (FAn)	0017H
	7 to C	Reserved	–
	D	Keypad connection fault (oPr)	001EH
	E	EEPROM write error (Err)	001FH
	F	Reserved	–
122H (1015H)	Fault contents 3		–
	0	MEMOBUS/Modbus communication fault (CE)	0021H
	1	Option communications error (bUS)	0022H
	2 to 5	Reserved	–
	6	Option card external fault (EF0)	0027H
	7 to E	Reserved	–
F	Hardware fault (including of□)	0030H	
123H (1016H)	Fault contents 4		–
	0 to F	Reserved	–
124H (1017H)	Fault contents 5		–
	0	Reserved	–
	1	External fault (input terminal S1) (EF1)	0042H
	2	External fault (input terminal S2) (EF2)	0043H
	3, 4	Reserved	–
	5	Current offset fault (CoF)	0046H
6 to F	Reserved	–	
125H (1018H)	Fault contents 6		–
	0	Reserved	–
	1	Node setup fault (nSE)	0052H
2 to F	Reserved	–	
126H (1019H)	Fault contents 7		–
	0	Power supply module undervoltage (Uv4)	0061H
	1 to 4	Reserved	–
	5	Power supply undervoltage (AUv)	0066H
	6	Power supply overvoltage (Aov)	0067H
	7	Power supply frequency fault (Fdv)	0068H
	8	Power phase rotation variation (SrC)	0069H
	9	Input power supply fault (PF2)	006AH
	A	Input phase loss 3 (PF3)	006BH
	B to E	Reserved	–
F	AC fuse blowout (FUA)	0070H	

Extended Command Code (Monitor Code)	Fault Name		Fault Code (U2, U3)
	BIT		
130H (101CH)	CPF contents 1		–
	0, 1	Reserved	–
	2	A/D conversion error (CPF02)	0083H
	3	PWM data error (CPF03)	0084H
	4, 5	Reserved	–
	6	EEPROM data error (CPF06)	0087H
	7	Terminal board communication error (CPF07)	0088H
	8	EEPROM serial communication fault (CPF08)	0089H
	9, A	Reserved	–
	B	RAM fault (CPF11)	008CH
	C	Flash memory fault (CPF12)	008DH
	D	Watchdog circuit exception (CPF13)	008EH
	E	Control circuit fault (CPF14)	008FH
F	Reserved	–	
131H (101DH)	CPF contents 2		–
	0	Clock fault (CPF16)	0091H
	1	Timing fault (CPF17)	0092H
	2	Control circuit fault (CPF18)	0093H
	3	Control circuit fault (CPF19)	0094H
	4	Hardware fault at power up (CPF20)	0095H
	5	Hardware fault at communication start up (CPF21)	0096H
	6	A/D conversion fault (CPF22)	0097H
	7	Reserved	–
	8	Converter capacity signal fault (CPF24)	0099H
	9	Terminal board is not properly connected. (CPF25)	009AH
	A	ASIC BB circuit error (CPF26)	009BH
	B	ASIC PWM setting register error (CPF27)	009CH
	C	ASIC PWM pattern error (CPF28)	009DH
	D	ASIC on-delay error (CPF29)	009EH
	E	ASIC BBON error (CPF30)	009FH
F	ASIC code error (CPF31)	00A0H	
132H (101EH)	CPF contents 3		–
	0	ASIC start-up error (CPF32)	00A1H
	1	Watch-dog error (CPF33)	00A2H
	2	ASIC power/clock error (CPF34)	00A3H
	3	External A/D converter error (CPF35)	00A4H
	4 to 7	Reserved	–
	8	Control circuit error (CPF40)	00A9H
	9	Control circuit error (CPF41)	00AAH
	A	Control circuit error (CPF42)	00ABH
	B	Control circuit error (CPF43)	00ACH
	C	Control circuit error (CPF44)	00ADH
	D	Control circuit error (CPF45)	00AEH
	E, F	Reserved	–

■ Energy-Saving Unit Alarm Contents

Table 37 Energy-Saving Unit Alarm Contents

Monitor Code	Alarm Name		Alarm Code (MEMOBUS/ Modbus Register 07FH)
	BIT		
101FH	Alarm contents 1		–
	0	Undervoltage (Uv)	0001H
	1	Overvoltage (ov)	0002H
	2	Heatsink Overheat (oH)	0003H
	3	Converter Overheat (oH2)	0004H
	4 to 6	Reserved	–
	7	Converter Baseblock (bb)	0008H
	8	External Fault (input terminal S3) (EF3)	0009H
	9	External Fault (input terminal S4) (EF4)	000AH
	A	External Fault (input terminal S5) (EF5)	000BH
	B	External Fault (input terminal S6) (EF6)	000CH
	C	External Fault (input terminal S7) (EF7)	000DH
	D	External Fault (input terminal S8) (EF8)	000EH
	E	Cooling Fan Error (FAn)	000FH
	F	Reserved	–
1020H	Alarm contents 2		–
	0, 1	Reserved	–
	2	Keypad Connection Fault (oPr)	0013H
	3	MEMOBUS/Modbus Communication Error (CE)	0014H
	4	Option Card Communications Error (bUS)	0015H
	5	Serial Communication Transmission Error (CALL)	0016H
	6	Reserved	–
	7	Converter Overload (oL2)	0018H
	8	Reserved	–
	9	Option Card External Fault (EF0)	001AH
	A, B	Reserved	–
	C	Serial Communication Transmission Error (CALL)	001DH
	D, E	Reserved	–
	F	MEMOBUS/Modbus Test Mode Fault (SE)	0020H
1021H	Alarm contents 3		–
	0 to F	Reserved	–
1022H	Alarm contents 4		–
	0	Reserved	–
	1	Station Number Setting Error (AEr)	0032H
	2	Reserved	–
	3	Current Alarm (HCA)	0034H
	4	Cooling Fan Maintenance Time (LT-1)	0035H
	5	Capacitor Maintenance Time (LT-2)	0036H
	6, 7	Reserved	–
	8	External Fault (input terminal S1) (EF1)	0039H
	9	External Fault (input terminal S2) (EF2)	003AH
A to F	Reserved	–	
1023H	Alarm contents 5		–
	0, 1	Reserved	–
	2	Soft Charge Bypass Relay Maintenance Time (LT-3)	0043H
	3 to E	Reserved	–
F	Power supply undervoltage (AUv)	0050H	

11 European Standards



Figure 30 CE Mark

The CE mark indicates compliance with European safety and environmental regulations. It is required for engaging in business and commerce in Europe.

European standards include the Machinery Directive for machine manufacturers, the Low Voltage Directive for electronics manufacturers, and the EMC guidelines for controlling noise.

This option displays the CE mark based on the EMC guidelines.

EMC Guidelines: 2014/30/EU

Drives used in combination with this option and devices used in combination with the drive must also be CE certified and display the CE mark. When using drives displaying the CE mark in combination with other devices, it is ultimately the responsibility of the user to ensure compliance with CE standards. Verify that conditions meet European standards after setting up the device.

◆ EMC Guidelines Compliance

This option is tested according to European standards EN 61800-3:2004/A1:2012 and complies with EMC guidelines. The CE marking is declared based on the harmonized standards.

■ EMC Guidelines Installation Conditions

Verify the following installation conditions to ensure that other devices and machinery used in combination with this option and drives also comply with EMC guidelines:

1. Use dedicated shield cable for the option and external device (encoder, I/O device, master), or run the wiring through a metal conduit.
2. Keep wiring as short as possible and ground the largest possible surface area of the shield to the metal panel according to [Figure 32](#).

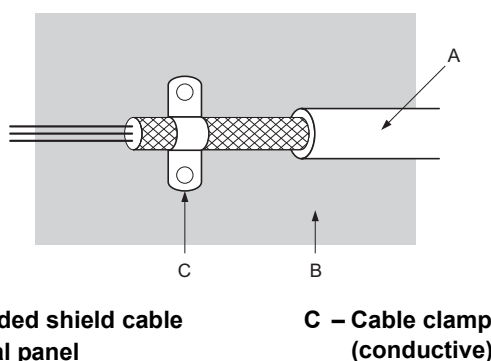

Figure 31 Ground Area

■ Option Installation for CE Compliance: Models PG-□□, DI-□□, DO-□□, AI-□□, AO-□□, SI-□□

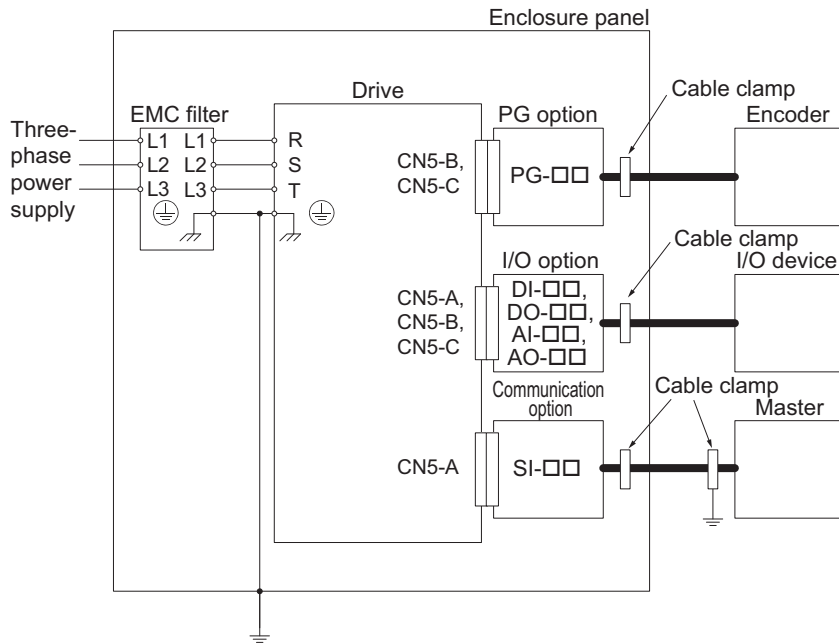

Figure 32 Option Installation for CE Compliance (PG-□□, DI-□□, DO-□□, AI-□□, AO-□□, SI-□□)

■ Option Installation for CE Compliance with GA500

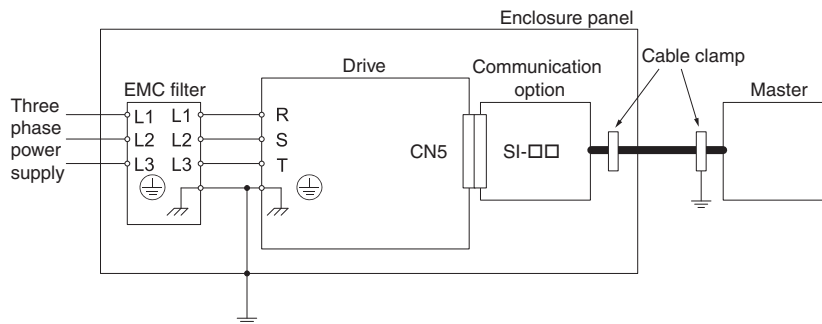

Figure 33 Option Installation for CE Compliance with GA500

12 Specifications

Table 38 Option Specifications

Items	Specifications
Model	SI-C3
CC-Link Version	Complies with CC-Link Ver.1.10
Station Type	Remote device station
No. of Occupied Stations	1
Communication Speed	156 kbps to 10 Mbps
Ambient Temperature	-10°C to +50°C (14°F to 122°F)
Humidity	up to 95% RH (no condensation)
Storage Temperature	-20°C to +60°C (-4°F to 140°F) allowed for short-term transport of the product
Area of Use	Indoors and free from: <ul style="list-style-type: none"> • Oil mist, corrosive gas, flammable gas, and dust • Radioactive materials or flammable materials, including wood • Harmful gas or fluids • Salt • Direct sunlight • Falling foreign objects
Altitude	Up to 1000 m (3280 ft)

Note: The number of drives that can be connected to the network varies depending on the type of nodes connected. Refer to page [24](#) for more information.

13 Disposal

◆ Disposal Instructions

Correctly dispose of this product and packing material as specified by applicable regional, local, and municipal laws and regulations.

◆ WEEE Directive



Figure 34 WEEE Mark

The wheeled bin symbol on this product, its manual, or its packaging identifies that you must recycle it at the end of its product life.

You must discard the product at an applicable collection point for electrical and electronic equipment (EEE).

Do not discard the product with usual waste.

◆ Revision History

The revision dates and numbers of the revised manuals are given on the bottom of the back cover.

MANUAL NO. SIEP C730600 83B <1>

Revision number

Published in Japan October 2016

Date of publication

Date of Publication	Rev. No.	Section	Revised Content
February 2019	<3>	All	Addition: Applicable product series Revision: Reviewed and corrected entire documentation.
		Chapter 13	Addition: Disposal
December 2018	<2>	All	Addition: Applicable product series Revision: Reviewed and corrected entire documentation.
		Back cover	Revision: Address
October 2016	<1>	All	Revision: Applicable product series
		Back cover	Revision: Address
June 2016	–	–	First edition

YASKAWA AC Drive Option

CC-Link

Technical Manual

DRIVE CENTER (INVERTER PLANT)

2-13-1, Nishimiyaichi, Yukuhashi, Fukuoka, 824-8511, Japan
Phone: +81-930-25-2548 Fax: +81-930-25-3431
<http://www.yaskawa.co.jp>

YASKAWA ELECTRIC CORPORATION

New Pier Takeshiba South Tower, 1-16-1, Kaigan, Minatoku, Tokyo, 105-6891, Japan
Phone: +81-3-5402-4502 Fax: +81-3-5402-4580
<http://www.yaskawa.co.jp>

YASKAWA AMERICA, INC.

2121, Norman Drive South, Waukegan, IL 60085, U.S.A.
Phone: +1-800-YASKAWA (927-5292) or +1-847-887-7000 Fax: +1-847-887-7310
<http://www.yaskawa.com>

YASKAWA ELÉTRICO DO BRASIL LTDA.

777, Avenida Piraporinha, Diadema, São Paulo, 09950-000, Brasil
Phone: +55-11-3585-1100 Fax: +55-11-3585-1187
<http://www.yaskawa.com.br>

YASKAWA EUROPE GmbH

Hauptstraße 185, 65760 Eschborn, Germany
Phone: +49-6196-569-300 Fax: +49-6196-569-398
<http://www.yaskawa.eu.com> E-mail: info@yaskawa.eu.com

YASKAWA ELECTRIC KOREA CORPORATION

35F, Three IFC, 10 Gukjegeumyung-ro, Yeongdeungpo-gu, Seoul, 07326, Korea
Phone: +82-2-784-7844 Fax: +82-2-784-8495
<http://www.yaskawa.co.kr>

YASKAWA ASIA PACIFIC PTE. LTD.

30A, Kallang Place, #06-01, 339213, Singapore
Phone: +65-6282-3003 Fax: +65-6289-3003
<http://www.yaskawa.com.sg>

YASKAWA ELECTRIC (THAILAND) CO., LTD.

59, 1st-5th Floor, Flourish Building, Soi Ratchadapisek 18, Ratchadapisek Road, Huaykwang, Bangkok, 10310, Thailand
Phone: +66-2-017-0099 Fax: +66-2-017-0799
<http://www.yaskawa.co.th>

YASKAWA ELECTRIC (CHINA) CO., LTD.

22F, Link Square 1, No.222, Hubin Road, Shanghai, 200021, China
Phone: +86-21-5385-2200 Fax: +86-21-5385-3299
<http://www.yaskawa.com.cn>

YASKAWA ELECTRIC (CHINA) CO., LTD. BEIJING OFFICE

Room 1011, Tower W3 Oriental Plaza, No. 1, East Chang An Ave.,
Dong Cheng District, Beijing, 100738, China
Phone: +86-10-8518-4086 Fax: +86-10-8518-4082

YASKAWA ELECTRIC TAIWAN CORPORATION

12F, No. 207, Sec. 3, Beishin Rd., Shindian Dist., New Taipei City 23143, Taiwan
Phone: +886-2-8913-1333 Fax: +886-2-8913-1513 or +886-2-8913-1519
<http://www.yaskawa.com.tw>

YASKAWA INDIA PRIVATE LIMITED

#17/A, Electronics City, Hosur Road, Bangalore, 560 100 (Karnataka), India
Phone: +91-80-4244-1900 Fax: +91-80-4244-1901
<http://www.yaskawaindia.in>

YASKAWA

YASKAWA ELECTRIC CORPORATION

In the event that the end user of this product is to be the military and said product is to be employed in any weapons systems or the manufacture thereof, the export will fall under the relevant regulations as stipulated in the Foreign Exchange and Foreign Trade Regulations. Therefore, be sure to follow all procedures and submit all relevant documentation according to any and all rules, regulations and laws that may apply.

Specifications are subject to change without notice for ongoing product modifications and improvements.

© 2016 YASKAWA ELECTRIC CORPORATION

MANUAL NO. SIEP C730600 83D <3>-0

Published in Japan February 2019
18-11-20