

YASKAWA AC Drive Option **EtherNet/IP** Technical Manual

Type: SI-EN3

To properly use the product, read this manual thoroughly and retain for easy reference, inspection, and maintenance. Ensure the end user receives this manual.

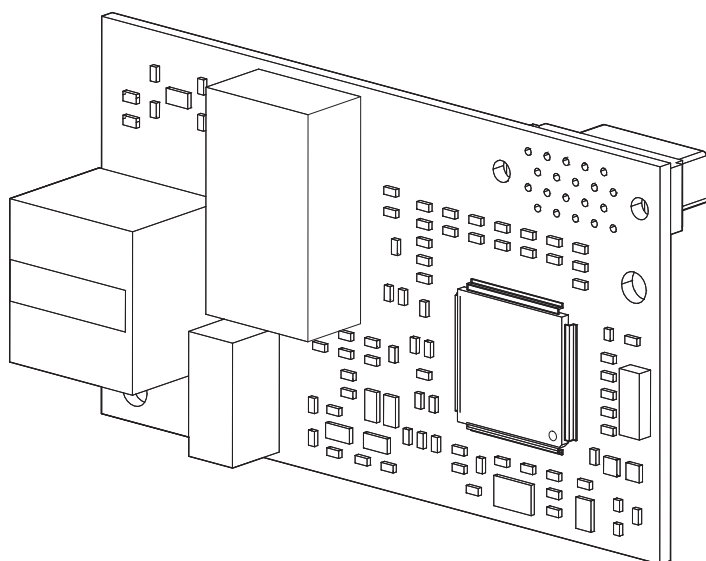

Copyright © 2016 YASKAWA ELECTRIC CORPORATION

All rights reserved. No part of this publication may be reproduced, stored in a retrieval system, or transmitted, in any form or by any means, mechanical, electronic, photocopying, recording, or otherwise, without the prior written permission of Yaskawa. No patent liability is assumed with respect to the use of the information contained herein. Moreover, because Yaskawa is constantly striving to improve its high-quality products, the information contained in this manual is subject to change without notice. Every precaution has been taken in the preparation of this manual. Yaskawa assumes no responsibility for errors or omissions. Neither is any liability assumed for damages resulting from the use of the information contained in this publication.

Table of Contents

1 PREFACE AND SAFETY	4
2 OVERVIEW	6
3 RECEIVING	8
4 OPTION COMPONENTS	9
5 INSTALLATION PROCEDURE	11
6 RELATED DRIVE PARAMETERS	25
7 CONFIGURING MESSAGING	29
8 OUTPUT ASSEMBLIES (DRIVE CONSUMES)	30
9 INPUT ASSEMBLIES (DRIVE PRODUCES)	47
10 GENERAL CLASS OBJECTS	67
11 VENDOR-SPECIFIC (YASKAWA) CLASS OBJECTS	76
12 WEB INTERFACE	78
13 TROUBLESHOOTING	81
14 OPTION INSTALLATION	85
15 SPECIFICATIONS	86
16 DISPOSAL	87

1 Preface and Safety

YASKAWA Electric supplies component parts for use in a wide variety of industrial applications. The selection and application of YASKAWA products remain the responsibility of the equipment designer or end user. YASKAWA accepts no responsibility for the way its products are incorporated into the final system design. Under no circumstances should any YASKAWA product be incorporated into any product or design as the exclusive or sole safety control. Without exception, all controls should be designed to detect faults dynamically and fail safely under all circumstances. All products designed to incorporate a component part manufactured by YASKAWA must be supplied to the end user with appropriate warnings and instructions as to the safe use and operation of that part. Any warnings provided by YASKAWA must be promptly provided to the end user. YASKAWA offers an express warranty only as to the quality of its products in conforming to standards and specifications published in the manual. **NO OTHER WARRANTY, EXPRESS OR IMPLIED, IS OFFERED.** YASKAWA assumes no liability for any personal injury, property damage, losses, or claims arising from misapplication of its products.

◆ Applicable Documentation

The following manuals are available for the SI-EN3 option:

SI-EN3 Option

YASKAWA AC Drive Option SI-EN3 EtherNet/IP Installation Manual Manual No: TOBP C730600 92	This guide is packaged together with the product and contains information necessary to install the option and set related drive parameters.
YASKAWA AC Drive Option SI-EN3 EtherNet/IP Technical Manual Manual No: SIEP C730600 92 (This book)	The technical manual contains detailed information about the option. Access the following sites to obtain the technical manual: U.S.: http://www.yaskawa.com Europe: http://www.yaskawa.eu.com Japan: http://www.e-mechatronics.com Other areas: Check the back cover of these manuals. For questions, contact Yaskawa or a Yaskawa representative.

Drive

YASKAWA AC Drive Manuals	Drive manuals contain basic installation and wiring information in addition to detailed parameter setting, fault diagnostic, and maintenance information. The most recent versions of these manuals are available for download on our documentation websites: U.S.: http://www.yaskawa.com Europe: http://www.yaskawa.eu.com Japan: http://www.e-mechatronics.com Other areas: Check the back cover of these manuals. For questions, contact Yaskawa or a Yaskawa representative.
-------------------------------------	---

◆ Terms

- Note:** Indicates supplemental information that is not related to safety messages.
- Option:** YASKAWA AC Drive Option SI-EN3 EtherNet/IP
- Drive:**
- YASKAWA AC Drive 1000-Series (A1000, U1000, U1000L, Z1000U, Z1000)
 - YASKAWA AC Drive GA500
 - YASKAWA AC Drive GA700
 - YASKAWA AC Drive GA800
- Keypad:**
- LCD Operator for YASKAWA AC Drive 1000-Series
 - LED Operator for YASKAWA AC Drive 1000-Series
 - LCD Keypad for YASKAWA AC Drive GA500, GA700, and GA800
 - LED Keypad for YASKAWA AC Drive GA500, GA700, and GA800

◆ Registered Trademarks

- EtherNet/IP is a trademark of the ODVA.
- All trademarks are the property of their respective owners.

◆ Supplemental Safety Information

Read and understand this manual before installing, operating, or servicing this option. The option must be installed according to this manual and local codes.

The following conventions are used to indicate safety messages in this manual. Failure to heed these messages could result in serious or possibly even fatal injury or damage to the products or to related equipment and systems.

DANGER

Indicates a hazardous situation, which, if not avoided, will cause death or serious injury.

WARNING

Indicates a hazardous situation, which, if not avoided, could cause death or serious injury.

CAUTION

Indicates a hazardous situation, which, if not avoided, could cause minor or moderate injury.

NOTICE

Indicates an equipment damage message.

■ General Safety

General Precautions

- The diagrams in this section may include options and drives without covers or safety shields to illustrate details. Be sure to reinstall covers or shields before operating any devices. The option should be used according to the instructions described in this manual.
- The diagrams in this manual are provided as examples only and may not pertain to all products covered by this manual.
- The products and specifications described in this manual or the content and presentation of the manual may be changed without notice to improve the product and/or the manual.
- Contact Yaskawa or a Yaskawa representative and provide the manual number shown on the front cover to order new copies of the manual.

DANGER

Heed the safety messages in this manual.

Failure to comply will cause death or serious injury.

The operating company is responsible for any injuries or equipment damage resulting from failure to heed the warnings in this manual.

WARNING

Electrical Shock Hazard

Do not modify the drive or option circuitry.

Modifications to circuitry can cause serious injury or death, will cause damage to the drive and option, and will void the warranty. Yaskawa is not responsible for modifications of the product made by the user.

NOTICE

Do not use steam or other disinfectants to fumigate wood for packaging the drive or option. Use alternative methods, for example heat treatment, before you package the components.

Gas from wood packaging fumigated with halogen disinfectants, for example fluorine, chlorine, bromine, iodine or DOP gas (phthalic acid ester), can cause damage to the drive and option.

2 Overview

The option provides a communications connection between the drive and an ODVA EtherNet/IP network. The option connects the drive to an EtherNet/IP network and facilitates the exchange of data.

This manual explains the handling, installation and specifications of this product.

EtherNet/IP is a communications link to connect industrial devices (such as smart motor controllers, operator interfaces, and variable frequency drives) as well as control devices (such as programmable controllers and computers) to a network. EtherNet/IP is a simple, networking solution that reduces the cost and time to wire and install factory automation devices, while providing interchangeability of like components from multiple vendors.

EtherNet/IP is an open device network standard.

Install the option/EtherNet/IP option on a drive to perform the following functions from a EtherNet/IP master device:

- Operate the drive
- Monitor the drive operation status
- Change drive parameter settings



◆ Compatible Products

The option can be used with the products in [Table 1](#).

Table 1 Compatible Products

Product Series	Model(s)	Software Version <1>
A1000	CIMR-A□2A□□□□	≥ 1020
	CIMR-A□4A0002 to 4A0675	
	CIMR-A□4A0930 and 4A1200	≥ 3015
U1000	CIMR-A□5A□□□□	≥ 5040
	CIMR-U□□A□□□□	≥ 1010
	CIMR-U□□E□□□□	
	CIMR-U□□P□□□□	
CIMR-U□□W□□□□		
U1000L	CIMR-U□□L□□□□	≥ 6210
	CIMR-U□□F□□□□	
	CIMR-U□□R□□□□	
	CIMR-U□□S□□□□	
Z1000U	CIMR-Z□□A□□□□	≥6110
	CIMR-Z□□E□□□□	
	CIMR-Z□□P□□□□	
	CIMR-Z□□W□□□□	
Z1000	CIMR-Z□□A□□□□	≥ 1016
GA500 <2>	CIPR-GA50□□□□□	≥1010
GA700 <2>	CIPR-GA70□□□□□	≥1010
GA800 <2>	CIPR-GA80□□□□□	≥ 9010

<1> Refer to “PRG” on the drive nameplate for the software version number.

<2> Before you install the option on a YASKAWA AC Drive GA500, GA700, or GA800, make sure that the option software version is PRG: 4103 or later.

Note: 1. Refer to the option package labeling in the field designated “PRG” (four digit number)” to identify the option software version.

2. For Yaskawa customers in the North or South America region:

If your product is not listed in [Table 1](#), refer to the web page below to confirm this manual is correct for your product. The web page provides a list of option manuals by product, and a direct link to download a PDF.

Scan QR code

Or refer to: <http://www.yaskawa.com/optionlookup>

◆ Install the Option on a GA500 Drive

An option card installation case is necessary to install the option on a GA500 drive. The option card installation case model is: JOHB-GA500. This case is sold separately. Refer to the option card installation case manual for more information about installation.

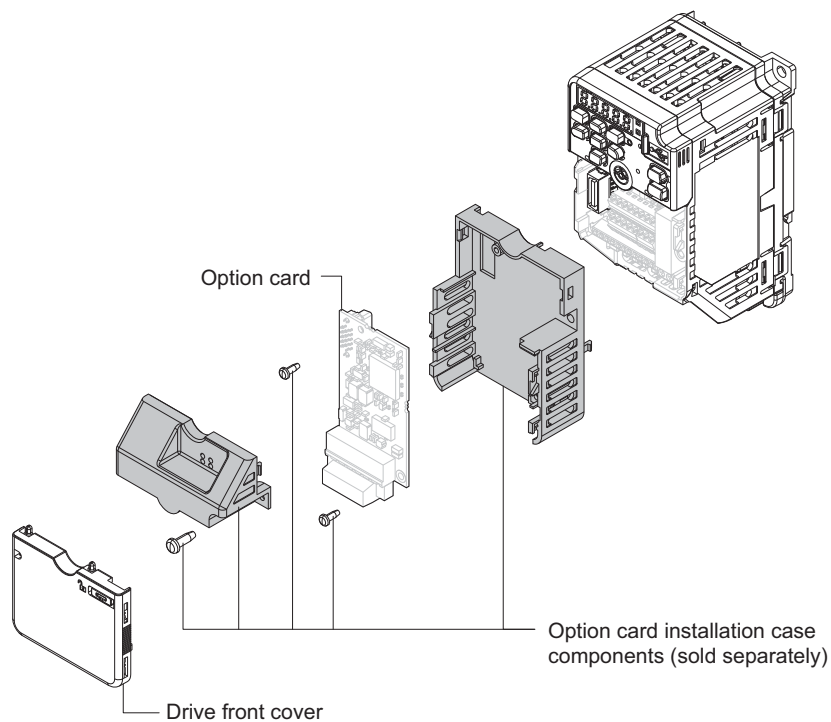

Figure 1 Option Card Installation Case

3 Receiving

After receiving the option package:







1. Make sure that the option is not damaged and no parts are missing. Contact your sales outlet if the option or other parts appear damaged.

NOTICE: Do not use damaged parts to connect the drive and the option. Failure to comply could damage the drive and option.

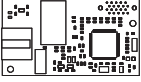
2. Confirm that the model number on the option nameplate and the model listed in the purchase order are the same. Refer to **Figure 2** on page 9 for details. Contact the distributor where the option was purchased or contact Yaskawa or a Yaskawa representative about any problems with the option.

◆ Option Package Components

Table 2 Option Package Components

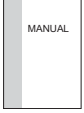
Description:	Option	Ground Wire <1>	Screws (M3)	LED Labels			Installation Manual
				A1000, U1000, U1000L, and Z1000U	Z1000	GA500, GA700, and GA800	
—							
Quantity:	1	1	3 <2>	1	1	1	1

<1> GA700 and GA800 drives do not use the ground wire.

<2> GA700 and GA800 drives use two screws only.

◆ Installation Tools

- A Phillips screwdriver. Phillips screw sizes vary by drive capacity.
- A flat-blade screwdriver (blade depth: 0.4 mm (0.02 in), width: 2.5 mm (0.1 in)).
- A pair of diagonal cutting pliers.
- A small file or medium-grit sandpaper.

4 Option Components

◆ SI-EN3 Option

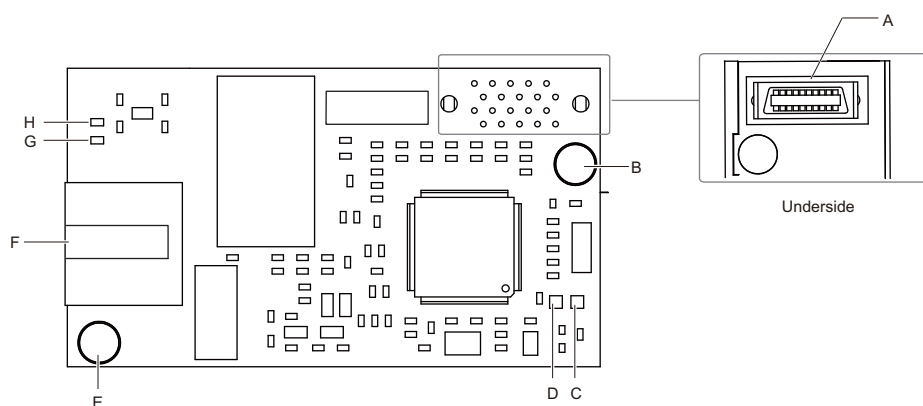

A – Connector (CN5)

B – Installation hole

C – LED (MS) <1>

D – LED (NS) <1>

E – Ground terminal (FE) and installation hole <2>

F – Communication connector CN1 (RJ45)

G – LED (LINK/ACT) <1>

H – LED (10/100) <1>

<1> Refer to **Option LED Display on page 10** for details on the LEDs.

<2> Connect the provided ground wire during installation. Installation on GA700 and GA800 drives does not require the ground wire.

Figure 2 SI-EN3 Option Components

◆ Communication Connector CN1

The communication connector on the option is a modular RJ45 female connector designated CN1. CN1 is the connection point for a customer-supplied male Ethernet network communication cable.

Table 3 Male 8-way Ethernet Modular Connector (Customer Supplied)

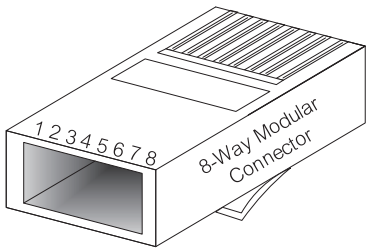
Male EtherNet 8-Way Modular Connector	Pin	Description
	1 (Pair 2)	Transmit data (TXD) +
	2 (Pair 2)	Transmit data (TXD) -
	3 (Pair 3)	Receive data (RXD) +
	4 (Pair 1)	Not used <1>
	5 (Pair 1)	Not used <1>
	6 (Pair 3)	Receive data (RXD) -
	7 (Pair 4)	Not used <1>
	8 (Pair 4)	Not used <1>

<1> Not used for 10 Mbps and 100 Mbps networks.

◆ Option LED Display

The option has four LEDs:

Bi-color Status LEDs:

- Module status (MS) red/green
- Network status (NS) red/green

Green Ethernet LEDs:

- Network speed-10/100 (MS) green
- Link status and network activity-Link/Act (NS) red/green

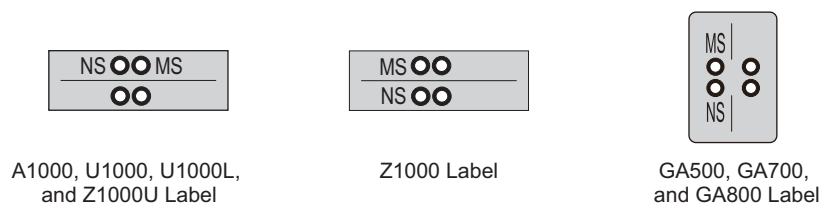

Figure 3 Option LED Labels

The operational states of the option LEDs after the power-up diagnostic LED sequence is completed are described in [Table 4](#). Wait at least 2 seconds for the power-up diagnostic process to complete before verifying the states of the LEDs.

Table 4 Option LED States

LED Name	Indication		Operating Status	Description
	Color	Status		
MS	–	OFF	Power supply OFF	Power is not being supplied to the drive
	Green	ON	Option operating	The option is operating normally
	Green	Flashing	Option initializing	The option is configuring an IP address
	Red	ON	Fatal error occurred	The option has detected a fatal (unrecoverable) error
	Red	Flashing	Non-fatal error occurred	The option has detected a non-fatal (recoverable) error
	Green/Red	Flashing	Option self-test	The option is in self-test mode
NS	–	OFF	Offline or Power supply OFF	–
	Green	ON	Online communications established	The option is online and has established connections
	Green	Flashing	Online communications not established	The option is online without an established connection
	Red	ON	Communications error (fatal)	The option detected a duplicate IP address
	Red	Flashing	Communications time-out (non-fatal)	A communications time-out occurred
	Green/Red	Flashing	Option self-test	The option is in self-test mode
10/100 </>	Green	OFF	10 Mbps is established	–
	Green	ON	100 Mbps is established	
LINK/ACT </>	Green	OFF	Link is not established	
	Green	ON	Link is established	
	Green	Flashing	Link is established and there is network activity	

<1> Remove the drive front cover to check the status of the LED. Be careful not to touch the main circuit terminals or the control board in the drive.

■ Power-Up Diagnostics

An LED test is performed each time the drive is powered up. The initial boot sequence may take several seconds. After the LEDs have completed the diagnostic LED sequence, the option is successfully initialized. The LEDs then assume operational conditions as shown in [Table 4](#).

Table 5 Power-Up Diagnostic LED Sequence

Sequence	Module Status (MS)	Network Status (NS)	Time (ms)
1	Green	OFF	250
2	Red	OFF	250
3	Green	OFF	–
4	Green	Green	250
5	Green	Red	250
6	Green	OFF	–

5 Installation Procedure

◆ Section Safety

DANGER

Electrical Shock Hazard

Do not inspect, connect, or disconnect any wiring while the drive is energized.

Failure to comply will cause death or serious injury.

Before servicing, disconnect all power to the equipment and wait for at least the time specified on the warning label. The internal capacitor remains charged even after the drive is de-energized. The charge indicator LED will extinguish when the DC bus voltage is below 50 Vdc. When all indicators are OFF, measure for unsafe voltages to confirm the drive is safe.

WARNING

Electrical Shock Hazard

Do not operate equipment with covers removed.

Failure to comply could cause death or serious injury.

The diagrams in this section may include options and drives without covers or safety shields to illustrate details. Reinstall covers and shields before operating the drive and run the drive according to the instructions described in this manual.

Do not allow unqualified personnel to perform work on the drive or option.

Failure to comply could cause death or serious injury.

Only authorized personnel familiar with installation, adjustment, and maintenance of AC drives and options may perform work.

Do not remove covers or touch circuit boards while the drive is energized.

Failure to comply could cause death or serious injury.

Do not use damaged wires, stress the wiring, or damage the wire insulation.

Failure to comply could cause death or serious injury.

Fire Hazard

Tighten all terminal screws to the specified tightening torque.

Loose or overtightened connections could cause erroneous operation and damage to the terminal block or start a fire and cause death or serious injury.

NOTICE

Damage to Equipment

Observe proper electrostatic discharge (ESD) procedures when handling the option, drive, and circuit boards.

Failure to comply could cause ESD damage to circuitry.

Never connect or disconnect the motor from the drive while the drive is outputting voltage.

Improper equipment sequencing could damage the drive.

Do not connect or operate any equipment with visible damage or missing parts.

Failure to comply could further damage the equipment.

Do not use unshielded wire for control wiring.

Failure to comply may cause electrical interference resulting in poor system performance. Use shielded, twisted-pair wires and ground the shield to the ground terminal of the drive.

NOTICE

Properly connect all pins and connectors on the option and drive.

Failure to comply could prevent proper operation and damage equipment.

Confirm that all connections are correct after installing the option and connecting peripheral devices.

Failure to comply could damage the option.

◆ Procedures for Installing and Wiring Options on a Drive

Procedures to install and wire the option are different for different drive models.

Refer to [Table 6](#) to check the procedures to install and wire the option on a drive.

Table 6 Procedures for Installing and Wiring Options on a Drive

Product Series	Procedures for Installing and Wiring Options on a Drive	Page
A1000	Procedure A	13
U1000	Procedure A	13
U1000L	Procedure A	13
Z1000U	Procedure A	13
Z1000	Procedure B	17
GA500	<1> <2>	–
GA700	Procedure C	21
GA800	Procedure C	21

[<1>](#) Use the option card installation case manual to install the option on GA500 drives.

[<2>](#) Before you install the option on a YASKAWA AC Drive GA500, make sure that the option software version is PRG: 4103 or later.

■ Procedure A

This section shows the procedure to install and wire the option on a 1000-series drive.

Prepare the Drive for the Option

1. Correctly wire the drive as specified by the manual packaged with the drive.
2. Make sure that the drive functions correctly.

Refer to [Figure 4](#) for an exploded view of the drive with the option and related components for reference in the installation procedure.

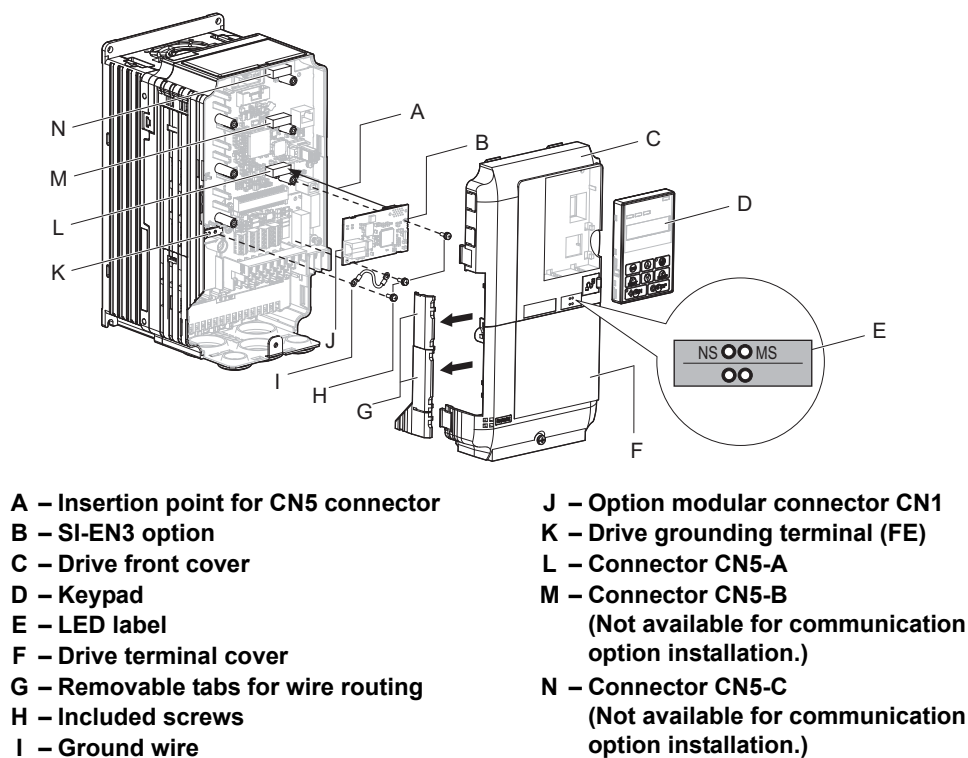

Figure 4 Drive Components with Option

5 Installation Procedure

Install the Option

Remove the front covers of the drive before you install the option.

Refer to the drive manual for information about how to remove the front covers. Different drive sizes have different cover removal procedures.

You can only install this option into the **CN5-A** connector on the drive control board.

DANGER! Electrical Shock Hazard. Do not inspect, connect, or disconnect any wiring while the drive is energized. Failure to comply will cause death or serious injury. Before servicing, disconnect all power to the equipment and wait for at least the time specified on the warning label. The internal capacitor remains charged even after the drive is de-energized. The charge indicator LED will extinguish when the DC bus voltage is below 50 Vdc. When all indicators are OFF, measure for unsafe voltages to confirm the drive is safe.

1. Shut off power to the drive, wait the appropriate amount of time for voltage to dissipate, then remove the keypad (D) and front covers (C, F).

Refer to the manual packaged with the drive for details on keypad and cover removal.

NOTICE: Damage to Equipment. Observe proper electrostatic discharge (ESD) procedures when handling the option, drive, and circuit boards. Failure to comply could cause ESD damage to circuitry.

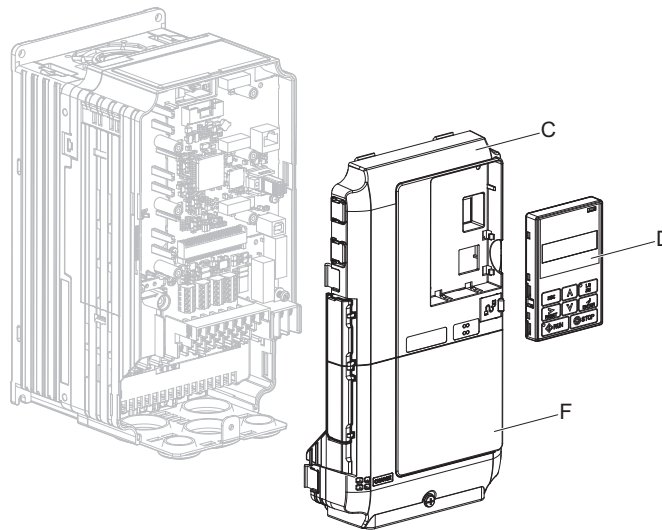

Figure 5 Remove the Keypad, Front Cover, and Terminal Cover

2. Affix the LED label (E) in the appropriate position on the drive front cover (C).

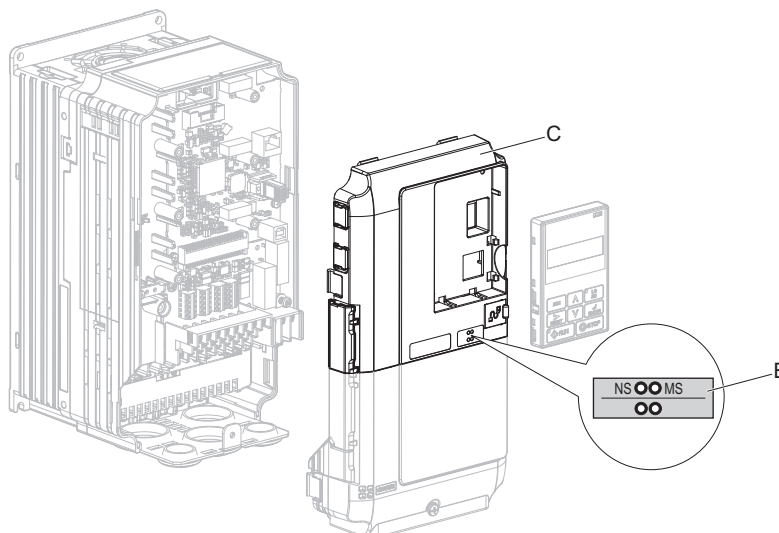

Figure 6 Affix the LED Label

3. Insert the option card (B) into the CN5-A (L) connector on the drive and fasten it into place using one of the included screws (H). Tighten the screw to 0.5 to 0.6 N·m (4.4 to 5.3 in·lb).

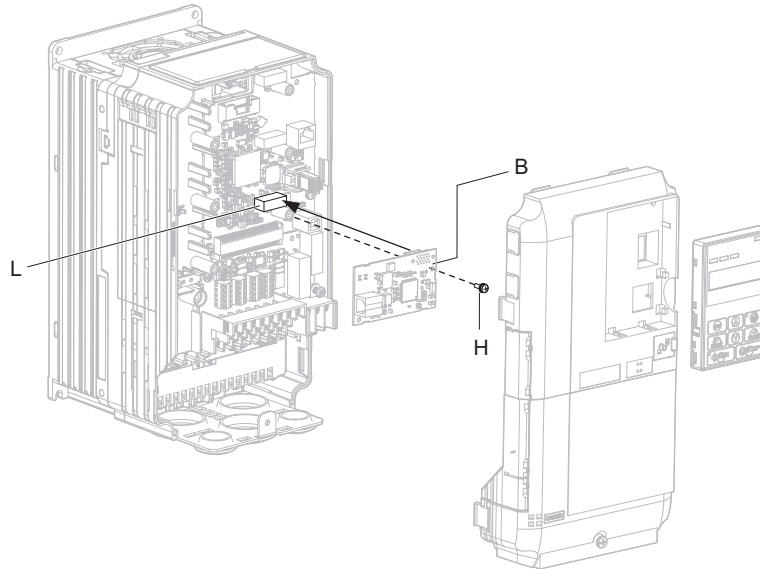

Figure 7 Insert the Option

4. Connect one end of the ground wire (I) to the ground terminal (K) using one of the remaining provided screws (H). Connect the other end of the ground wire (I) to the remaining ground terminal and installation hole on the option (B) using the last remaining provided screw (H). Tighten both screws to 0.5 to 0.6 N·m (4.4 to 5.3 in·lb).

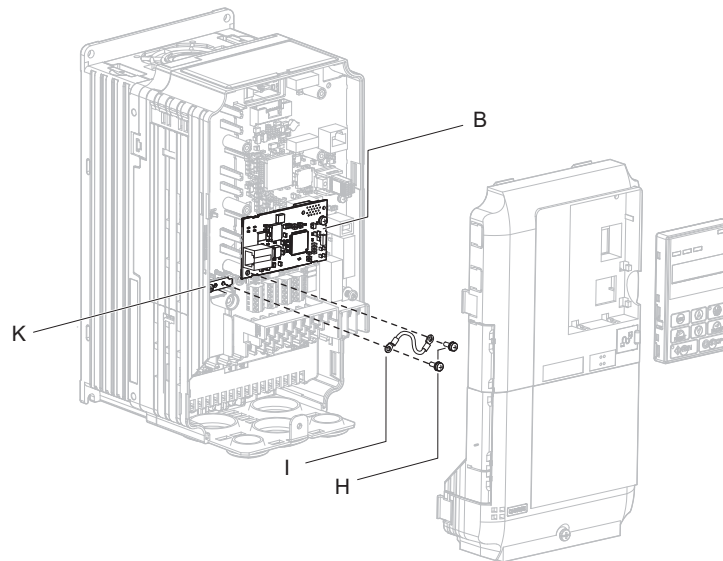

Figure 8 Connect the Ground Wire

Note: The drive has only two ground terminal screw holes (K). Two ground wires should share the same ground terminal when connecting three options.

5 Installation Procedure

5. Route the option wiring inside the enclosure as shown in [Figure 9-B](#). Take proper precautions so that the front covers will easily fit back onto the drive.
Users may also choose to route the option wiring through openings on the front cover of some models. Remove the perforated tabs on the left side of the front cover as shown in [Figure 9-A](#) to create the necessary openings on these models.
Refer to the Peripheral Devices & Options section of the drive instruction manual for more information.

Note: Separate communication cables from main circuit wiring and other electrical lines to avoid potential sources of electrical interference.

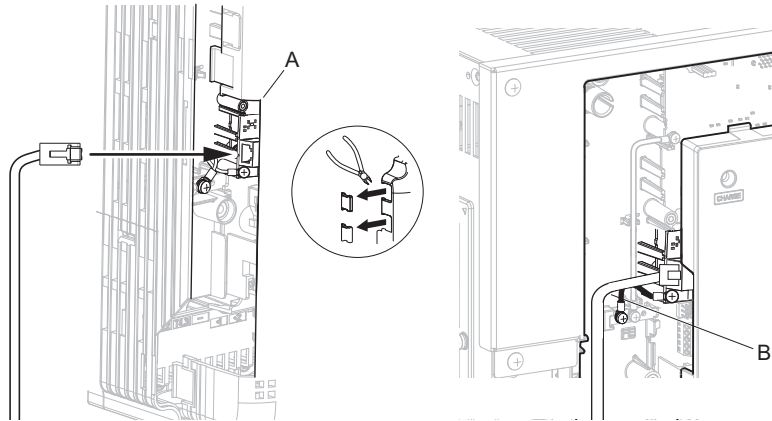

A – Route wires through the openings provided on the left side of the front cover. <1>

B – Use the open space provided inside the drive to route option wiring.

<1> The drive will not meet Enclosed wall-mounted type (IP20/UL Type 1) requirements if wiring is exposed outside the enclosure.

Figure 9 Wire Routing Examples

6. Firmly connect the Ethernet communication cable to the option modular connector (CN1).
Install Ethernet communications cables apart from main-circuit wiring and other electrical and power lines.
Ensure the cable end is firmly connected (see [Figure 23](#)). Refer to [Communication Cable Specifications on page 24](#) for details.
7. Reattach the drive front covers (C, F) and the keypad (D).

NOTICE: Do not pinch cables between the front covers and the drive. Failure to comply could cause erroneous operation.

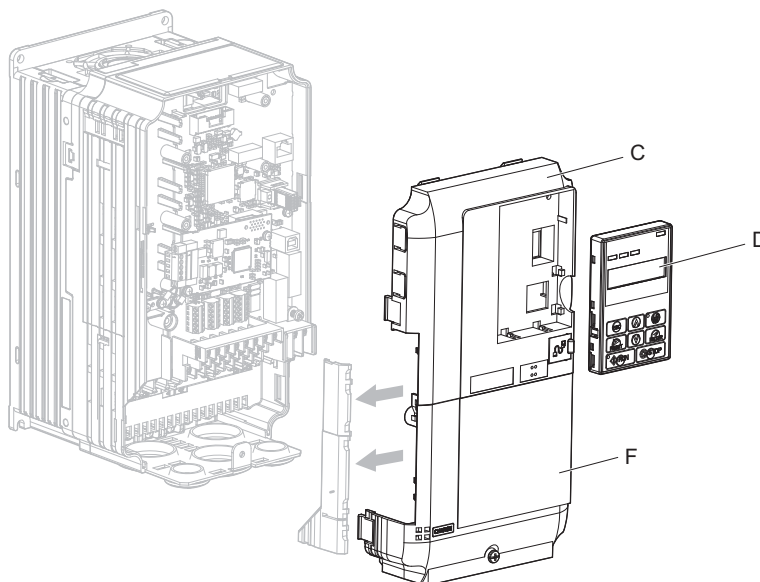

Figure 10 Replace the Front Covers and Keypad

8. Set drive parameters in [Table 7](#) for correct option performance.

■ Procedure B

This section shows the procedure to install and wire the option on a Z1000 drive.

Prepare the Drive for the Option

Prior to installing the option, wire the drive, make necessary connections to the drive terminals, and verify that the drive functions normally without the option installed. Refer to the User Manual packaged with the drive for information on wiring and connecting the drive.

Figure 11 shows an exploded view of the drive with the option and related components for reference.

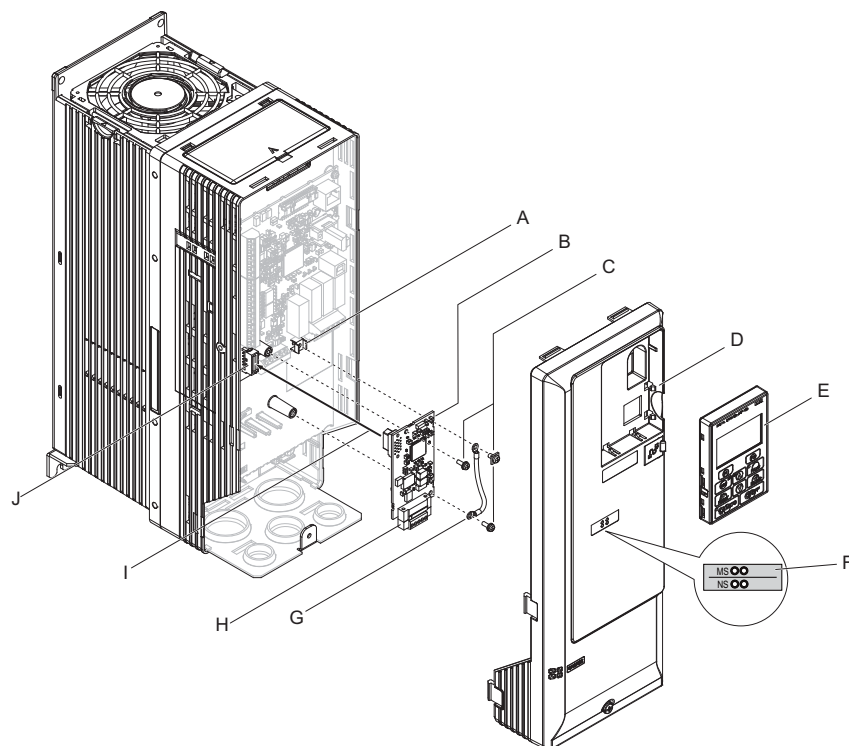

- | | |
|--|--------------------------------------|
| A – Drive grounding terminal (FE) | F – LED label |
| B – SI-EN3 option | G – Ground wire |
| C – Mounting screw | H – Terminal block CN1 |
| D – Drive front cover | I – Insert connector CN5 here |
| E – HOA keypad | J – Connector CN5 |

Figure 11 Drive Components with Option

5 Installation Procedure

Installing the Option

Remove the front cover of the drive before you install the option.

Refer to the drive manual for information about how to remove the front covers. Different drive sizes have different cover removal procedures.

DANGER! Electrical Shock Hazard. Do not inspect, connect, or disconnect any wiring while the power is on. Before wiring or servicing, disconnect all power to the equipment. The internal capacitor remains charged even after the power supply is turned off. The charge indicator LED will extinguish when the DC bus voltage is below 50 Vdc. To prevent electric shock, wait for at least the time specified on the warning label; after all indicators are OFF, measure the DC bus voltage level to confirm it has reached a safe level. Failure to comply could result in death or serious personal injury.

1. Shut off power to the drive, wait the appropriate amount of time for voltage to dissipate, then remove the HOA keypad (E) and front cover (D).

NOTICE: Damage to Equipment. Observe proper electrostatic discharge procedures (ESD) when handling the option, drive, and circuit boards. Failure to comply may result in ESD damage to circuitry.

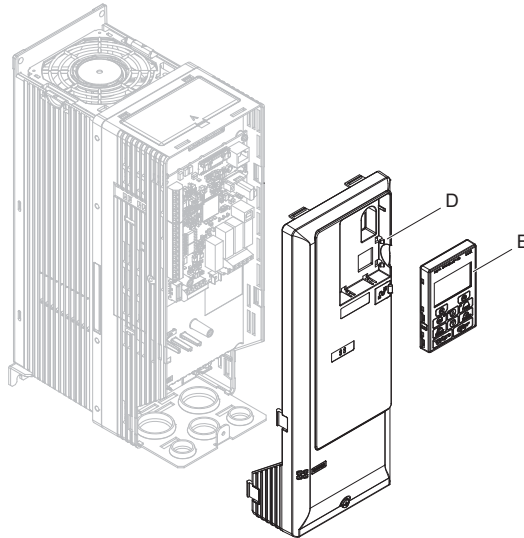

Figure 12 Remove the Front Cover and HOA Keypad

2. With the front cover and HOA keypad removed, apply the LED label (F) in the appropriate position on the drive front cover (D).

Note: Place the LED label vertically on Z1000 drives as shown in [Figure 13](#).

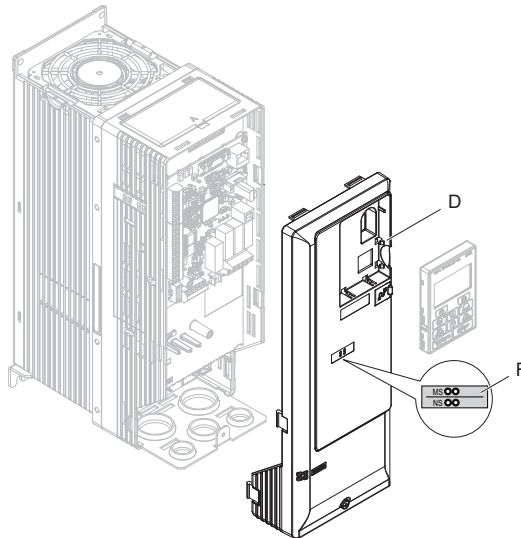

Figure 13 Apply the LED Label

3. Make sure the screws on the left and right sides of the option terminal block (H) are tightened with a tightening torque of 0.5 to 0.6 N·m (4.4 to 5.3 in·lb), then insert the option (B) into the CN5 connector (J) located on the drive and fasten it using one of the included screws (C).

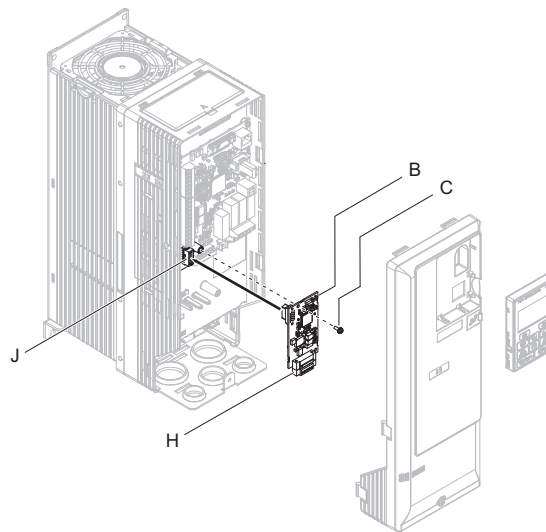

Figure 14 Insert the Option

4. Connect the ground wire (G) to the ground terminal (A) using one of the remaining provided screws (C). Connect the other end of the ground wire (G) to the ground terminal and installation hole on the option using the last remaining provided screw (C) and tighten both screws to 0.5 to 0.6 N·m (4.4 to 5.3 in·lb).

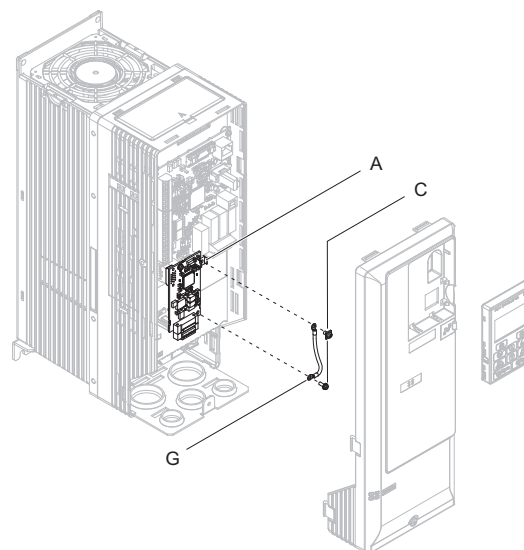

Figure 15 Connect the Ground Wire

5. Wire the communication cables.

Note: Separate communication cables from main circuit wiring and other electrical lines.

5 Installation Procedure

6. Firmly connect the Ethernet communication cable to the option modular connector (CN1).
Install Ethernet communications cables apart from main-circuit wiring and other electrical and power lines.
Ensure the cable end is firmly connected (see [Figure 23](#)). Refer to [Communication Cable Specifications on page 24](#) for details of installing.
7. Reattach the drive front cover (D) and the HOA Keypad (E).

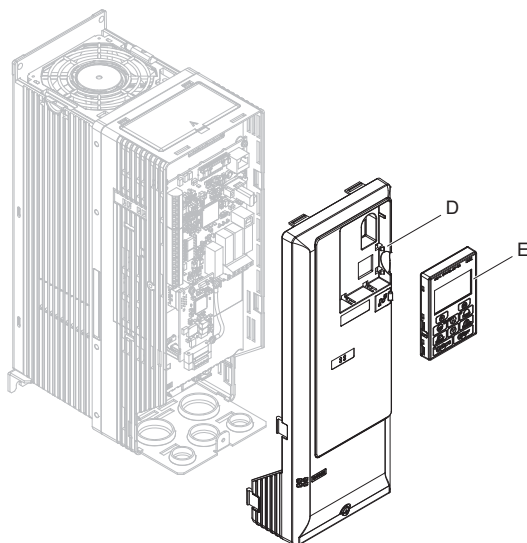

Figure 16 Replace the Front Cover and HOA Keypad

Note: Take proper precautions when wiring the option so that the front covers will easily fit back onto the drive. Make sure no cables are pinched between the front covers and the drive when replacing the covers.

8. Set drive parameters in [Table 7](#) for correct option performance.

■ Procedure C

This section shows the procedure to install and wire the option on a GA700 or GA800 drive.

Prepare the Drive for the Option

Before you install the option on a YASKAWA AC Drive GA700 or GA800, make sure that the option software version is PRG: 4103 or later.

1. Correctly wire the drive as specified by the manual packaged with the drive.

2. Make sure that the drive functions correctly.

Refer to [Figure 17](#) for an exploded view of the drive with the option and related components for reference in the installation procedure.

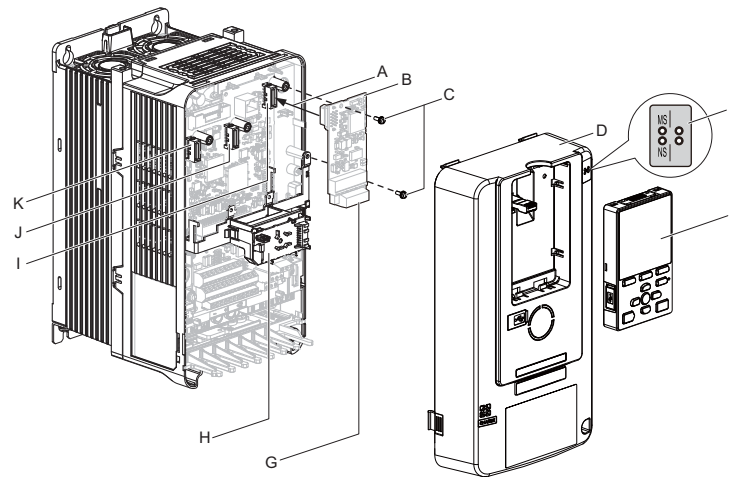

- | | |
|--|--|
| A – Insertion point for CN5 connector | I – Connector CN5-A |
| B – SI-EN3 option | J – Connector CN5-B |
| C – Included screws | (Not available for communication option installation.) |
| D – Drive front cover | K – Connector CN5-C |
| E – LED label | (Not available for communication option installation.) |
| F – Keypad | |
| G – Option modular connector CN1 | |
| H – LED Status Ring board | |

Figure 17 Drive Components with Option

Install the Option

Remove the front cover of the drive before you install the option.

Refer to the drive manual for information about how to remove the front cover. Different drive sizes have different cover removal procedures.

You can only install this option into the **CN5-A** connector on the drive control board.

DANGER! Electrical Shock Hazard. Do not inspect, connect, or disconnect any wiring while the drive is energized. Failure to comply will cause death or serious injury. Before servicing, disconnect all power to the equipment and wait for at least the time specified on the warning label. The internal capacitor remains charged even after the drive is de-energized. The charge indicator LED will extinguish when the DC bus voltage is below 50 Vdc. When all indicators are OFF, measure for unsafe voltages to confirm the drive is safe.

5 Installation Procedure

1. Affix the LED label (E) in the appropriate position on the drive front cover (D).

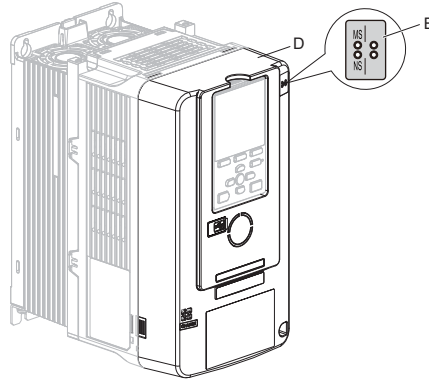

Figure 18 Affix the LED Label

2. Shut off power to the drive, wait the appropriate amount of time for voltage to dissipate, then remove the front cover (D).
Refer to the manual packaged with the drive for details on cover removal.

NOTICE: Damage to Equipment. Observe proper electrostatic discharge (ESD) procedures when handling the option, drive, and circuit boards. Failure to comply could cause ESD damage to circuitry.

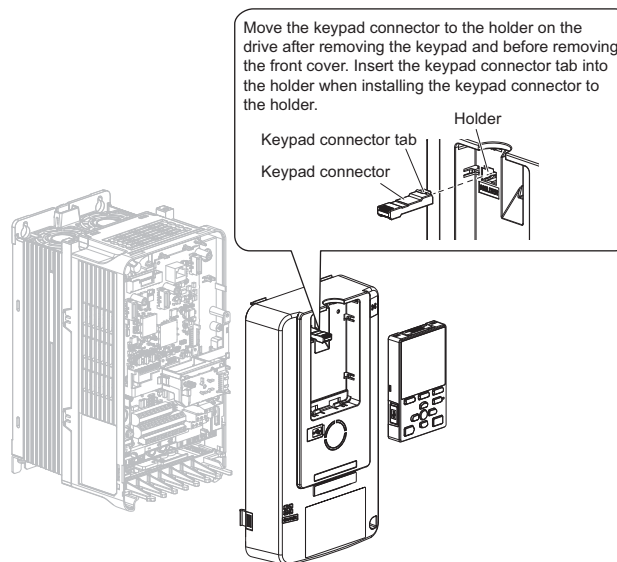

Figure 19 Remove the Front Cover and Keypad

3. Carefully remove the LED Status Ring board (H) and place it on the right side of the drive using the temporary placement holes.
Refer to the manual packaged with the drive for details on removing the LED Status Ring board.

NOTICE: Do not remove the LED Status Ring board cable connector. Failure to comply could cause erroneous operation and damage the drive.

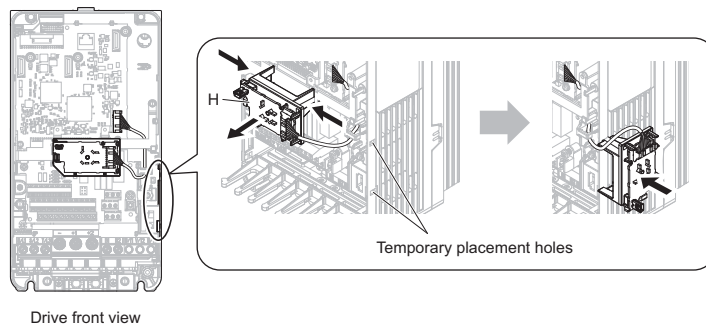

Figure 20 Remove the LED Status Ring Board

4. Insert the option card (B) into the CN5-A connector (I) on the drive and fasten it into place using the included screws (C). Tighten both screws to 0.5 to 0.6 N·m (4.4 to 5.3 in·lb).

Note: Only two screws are necessary to install the option on a GA700 or GA800 drive. A ground wire is not necessary. The option package ships with three screws and a ground wire for installation on other product series. Do not use the ground wire or the extra screw.

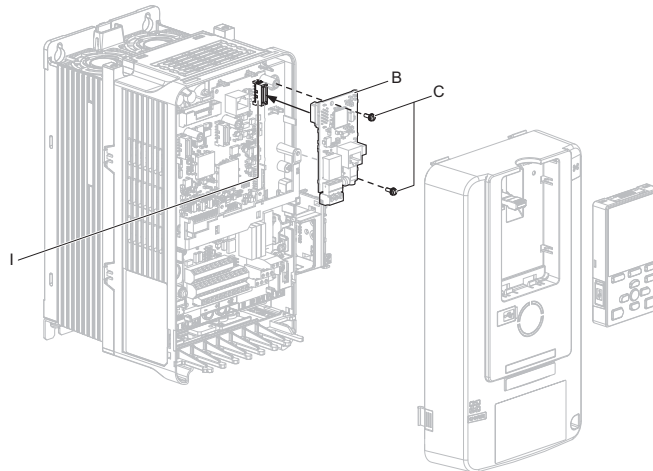

Figure 21 Insert the Option Card

5. Firmly connect the Ethernet communication cable to the option modular connector (CN1). Install Ethernet communications cables apart from main-circuit wiring and other electrical and power lines. Ensure the cable end is firmly connected (see [Figure 23](#)). Refer to [Communication Cable Specifications on page 24](#) for details.

Note: 1. Separate communication cables from main circuit wiring and other electrical lines.
2. Maximum transmission distance is 100 m (328 ft). Minimum wiring distance between stations is 0.2 m (7.9 in).

6. Reattach the LED Status Ring board (H). Use the open space provided inside the LED Status Ring board to route option wiring.

NOTICE: Do not pinch cables between the front cover or the LED Status Ring board and the drive. Failure to comply could cause erroneous operation.

7. Reattach the drive front cover (D) and the keypad (F).

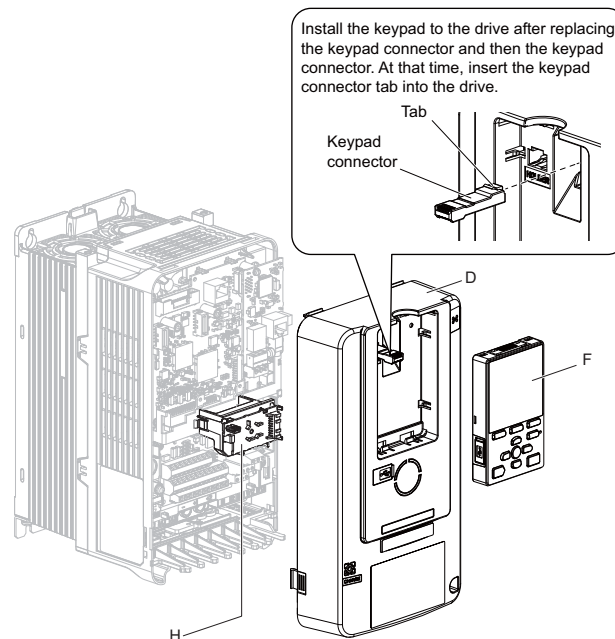

Figure 22 Replace the Front Cover and Keypad

8. Set drive parameters in [Table 7](#) for correct option performance.

◆ IGMP Snooping

Switches implementing IGMP Snooping are strongly recommended. When IGMP Snooping is used, devices will only receive the multicast packets in which they are interested.

◆ Communication Cable Specifications

Use only EtherNet/IP dedicated communication cable; the Yaskawa warranty does not cover other cable types. Refer to the ODVA website (www.odva.org) for more information on network cabling.

◆ Option Connection Diagram

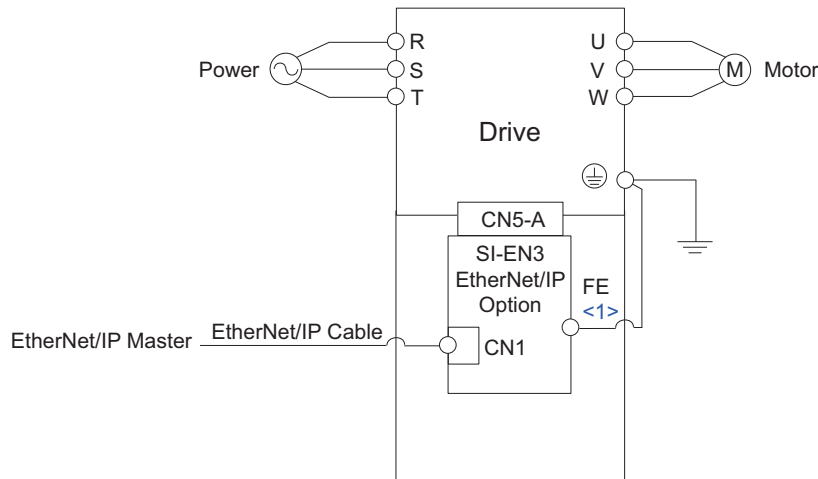

<1> Connect the provided ground wire for installations on 1000-series drives and GA500 drives.
The ground wire is not necessary for installation on GA700 or GA800 drives.

Figure 23 Option Connection Diagram

◆ EDS Files

For easy network implementation of drives equipped with the option, an EDS file can be obtained from:

U.S.: <http://www.yaskawa.com>

Europe: <http://www.yaskawa.eu.com>

Japan: <http://www.e-mechatronics.com>

Other areas: Check the back cover of these manuals.

For questions, contact Yaskawa or a Yaskawa representative.

Note: Download the EDS file for SI-EN3 option. The SI-EN3 will not function as a slave in the network without the appropriate EDS file.

6 Related Drive Parameters

The parameters in [Table 7](#) set the drive for operation with the option. Confirm proper setting of all parameters in [Table 7](#) before starting network communications. Refer to the manual packaged with the drive for details on setting parameters.

Note: Hex.: MEMOBUS addresses that you can use to change parameters over network communication are represented in hexadecimal numbers.

Table 7 Related Parameter Settings

No. (Hex.)	Name	Description	Values
b1-01 (0180) <I>	Reference 1 Source	Selects the input method for frequency reference. 0: Keypad 1: Analog Input 2: Memobus/Modbus Communications 3: Option PCB 4: Pulse Train Input	Default: 1 Range: 0 to 4 (Set to 3)
b1-02 (0181) <I>	Run Command 1 Source	Selects the input method for the Run command. 0: Keypad 1: Digital Input 2: Memobus/Modbus Communications 3: Option PCB	Default: 1 Range: 0 to 3 (Set to 3)
F6-01 (03A2)	Communication Error Selection	Selects drive response when a bUS error is detected during communications with the option. 0: Ramp to Stop 1: Coast to Stop 2: Fast Stop (Use C1-09) 3: Alarm Only <I> 4: Alarm - Run at d1-04 <I> <I> 5: Alarm - Ramp to Stop <I>	Default: 1 Range: 0 to 5 <I>
F6-02 (03A3)	Comm External Fault (EF0) Detect	Selects the condition for external fault detection (EF0). 0: Always detected 1: Detection during run only	Default: 0 Range: 0, 1
F6-03 (03A4)	Comm External Fault (EF0) Select	Selects drive response for external fault input (EF0) detection during option communications. 0: Ramp to Stop 1: Coast to Stop 2: Fast Stop (Use C1-09) 3: Alarm Only <I>	Default: 1 Range: 0 to 3
F6-06 (03A7) <I>	Torque Reference/Limit by Comm	Selects whether to enable or disable the torque reference and torque limit received from the communication option card. 0: Disabled 1: Enabled <I>	Default: 0 Range: 0, 1
F6-07 (03A8)	MultiStep Ref Priority Select	0: MultiStep References Disabled 1: MultiStep References Enabled	Default: 0 <I> Range: 0, 1
F6-08 (036A)	Comm Parameter Reset @Initialize	Selects whether communication-related parameters F6-□□ and F7-□□ are set back to original default values when the drive is initialized using parameter A1-03. 0: No Reset - Parameters retained 1: Reset - Back to factory default Note: The setting value is not changed even when F6-08 is set to 1 and the drive is initialized using A1-03.	Default: 0 <I> Range: 0, 1
F6-14 (03BB) <I>	Bus Error Auto Reset	Sets the automatic reset function for bUS [Option Communication Errors]. 0: Disabled 1: Enabled	Default: 0 Range: 0, 1
F6-15 (0B5B) <I>	Comm. Option Parameters Reload	Selects whether F6-□□/□□/□□/□□ communication-related parameters changed are enabled. 0: Reload at Next Power Cycle 1: Reload Now 2: Cancel Reload Request Note: F6-15 is reset to 0 after setting 1 or 2.	Default: 0 Range: 0 to 2
F7-01 (03E5) <I> <I> <I>	IP Address 1	Sets the static/fixed IP address. Parameter F7-01 sets the most significant octet.	Default: 192 Min: 0 Max: 255

6 Related Drive Parameters

No. (Hex.)	Name	Description	Values
F7-02 (03E6) <8> <11> <12>	IP Address 2	Sets the static/fixed IP address. Parameter F7-02 sets the second most significant octet.	Default: 168 Min: 0 Max: 255
F7-03 (03E7) <8> <11> <12>	IP Address 3	Sets the static/fixed IP address. Parameter F7-03 sets the third most significant octet.	Default: 1 Min: 0 Max: 255
F7-04 (03E8) <8> <11> <12>	IP Address 4	Sets the static/fixed IP address. Parameter F7-04 sets the fourth most significant octet.	Default: 20 Min: 0 Max: 255
F7-05 (03E9) <8>	Subnet Mask 1	Sets the static/fixed Subnet Mask. Parameter F7-05 sets the most significant octet.	Default: 255 Min: 0 Max: 255
F7-06 (03EA) <8>	Subnet Mask 2	Sets the static/fixed Subnet Mask. Parameter F7-06 sets the second most significant octet.	Default: 255 Min: 0 Max: 255
F7-07 (03EB) <8>	Subnet Mask 3	Sets the static/fixed Subnet Mask. Parameter F7-07 sets the third most significant octet.	Default: 255 Min: 0 Max: 255
F7-08 (03EC) <8>	Subnet Mask 4	Sets the static/fixed Subnet Mask. Parameter F7-08 sets the fourth most significant octet.	Default: 0 Min: 0 Max: 255
F7-09 (03ED) <8>	Gateway Address 1	Sets the static/fixed Gateway address. Parameter F7-09 sets the most significant octet.	Default: 192 Min: 0 Max: 255
F7-10 (03EE) <8>	Gateway Address 2	Sets the static/fixed Gateway address. Parameter F7-10 sets the second most significant octet.	Default: 168 Min: 0 Max: 255
F7-11 (03EF) <8>	Gateway Address 3	Sets the static/fixed Gateway address. Parameter F7-11 sets the third most significant octet.	Default: 1 Min: 0 Max: 255
F7-12 (03F0) <8>	Gateway Address 4	Sets the static/fixed Gateway address. Parameter F7-12 sets the fourth most significant octet.	Default: 1 Min: 0 Max: 255
F7-13 (03F1) <8>	Address Mode at Startup	Selects how the option address is set. 0: Static <12> 1: BOOTP 2: DHCP	Default: 2 Range: 0 to 2
F7-14 (03F2)	Duplex Mode Selection	Selects duplex mode setting. 0: Half/Half 1: Auto/Auto 2: Full/Full 3: Half/Auto 4: Half/Full 5: Auto/Half 6: Auto/Full 7: Full/Half 8: Full/Auto	Default: 1 Range: 0 to 8
F7-15 (03F3) <13>	Communication Speed Selection	Sets the communication speed 10: 10/10 Mbps 100: 100/100 Mbps 101: 10/100 Mbps 102: 100/10 Mbps Note: Setting 10 applies to SI-EN3 because it is single port.	Default: 10 Range: <14>
F7-16 (03F4) <9>	Timeout Value	Sets the detection time for a communications timeout. Note: Set this parameter to 0.0 to disable the connection timeout function.	Default: 0.0 s Min.: 0.0 s Max.: 30.0 s
F7-17 (03F5)	EtherNet/IP Speed Scaling Factor	Sets the scaling factor for the speed monitor in EtherNet/IP Class ID 2AH Object.	Default: 0 Min.: -15 Max.: 15

No. (Hex.)	Name	Description	Values
F7-18 (03F6)	EtherNet/IP Current Scaling Factor	Sets the scaling factor for the output current monitor in EtherNet/IP Class ID 2AH Object.	Default: 0 Min.: -15 Max.: 15
F7-19 (03F7)	EtherNet/IP Torque Scaling Factor	Sets the scaling factor for the torque monitor in EtherNet/IP Class ID 2AH Object.	Default: 0 Min.: -15 Max.: 15
F7-20 (03F8)	EtherNet/IP Power Scaling Factor	Sets the scaling factor for the power monitor in EtherNet/IP Class ID 2AH Object.	Default: 0 Min.: -15 Max.: 15
F7-21 (03F9)	EtherNet/IP Voltage Scaling Factor	Sets the scaling factor for the voltage monitor in EtherNet/IP Class ID 2AH Object.	Default: 0 Min.: -15 Max.: 15
F7-22 (03FA)	EtherNet/IP Time Scaling	Sets the scaling factor for the time monitor in EtherNet/IP Class ID 2AH Object.	Default: 0 Min.: -15 Max.: 15
F7-23 to F7-27 (03FB to 03FF) F7-28 to F7-32 (0370 to 0374)	Dynamic Output Assembly Parameters	Parameters used in Output Assemblies 116, 117, 118, 119, 120. Each parameter contains a MEMOBUS/Modbus address. The value received for the Output Assembly will be written to this corresponding MEMOBUS/Modbus address. A MEMOBUS/Modbus address value of 0 means that the value received for the Output Assembly will not be written to any MEMOBUS/Modbus register.	Default: 0
F7-33 to F7-42 (0375 to 037E)	Dynamic Input Assembly Parameters	Parameters used in Input Assemblies 166, 167, 168, 169, 170. Each parameter contains a MEMOBUS/Modbus address. The value sent for the Input Assembly will be read from this corresponding MEMOBUS/Modbus address. A MEMOBUS/Modbus address value of 0 means that the value sent for the Input Assembly is not defined by the user, therefore the option default register value will be returned. <i>Refer to Input Assemblies (Drive Produces) on page 47</i> for definitions of the default MEMOBUS/Modbus registers.	Default: 0

- <1> Set b1-02 = 3 to start and stop the drive with the EtherNet/IP master device using serial communications.
Set b1-01 = 3 to control the frequency reference of the drive via the master device.
- <2> Setting this parameter to 3 or 4 will cause the drive to continue operation after detecting a fault. Take proper measures such as installing an emergency stop switch when using settings 3 or 4.
- <3> Refer to the drive manual to know if settings 4 and 5 are available. Settings 4 and 5 are available in A1000 software versions PRG: 1021 and later.
- <4> The setting range for 1000-Series drives is different for different software versions. Refer to the instruction manual of a specific drive for more information.
- <5> Control method availability of this parameter depends on product series.
 - 1000-Series Drives: Parameter is available in CLV, AOLV/PM, and CLV/PM. In AOLV/PM, this value is read as the Torque Limit.
 - GA500 Drive: Parameter is available in OLV, AOLV/PM, and EZOLV. This value is read as the Torque Limit.
 - GA700, GA800 Drives: Parameter is available in OLV, CLV, AOLV, AOLV/PM, CLV/PM, and EZOLV. In OLV and EZOLV, this value is read as the Torque Limit.
- <6> The setting specifies that network communications provide the torque reference or torque limit. The motor may not rotate if the PLC does not supply a torque reference or torque limit.
- <7> Default setting is 1 for GA500.
- <8> Set F7-01 to F7-12 when F7-13 is set to 0.
- <9> Available in A1000 software versions PRG: 1021 and later.
- <10> Supported in option software versions PRG: 4103 and later on non-1000-series drives.
- <11> Cycle power for setting changes to take effect. Set F6-15 to 1 (Enable), to have settings take effect immediately on non-1000 series drives.
- <12> Set F7-01 to F7-04 when F7-13 is set to 0. All IP Addresses (F7-01 to F7-04) must be unique.
- <13> Set F7-15 when F7-14 is not set to 1 (Auto Negotiate).
- <14> Default and setting range of this parameter depend on drive series.
 - 1000-Series Drives, GA700, or GA800
Default: 10
Setting range: 10 to 102
 - GA500 Drives
Default: 10
Setting range: 10, 100

Table 8 Option Monitors

No.	Name	Description	Range
U6-80 to U6-83	OPT IP ADR 1 to 4	Displays IP Address currently available; <ul style="list-style-type: none"> • U6 -80: First octet • U6 -81: Second octet • U6 -82: Third octet • U6 -83: Forth octet 	0 to 255
U6-84 to U6-87	Online Subnet 1 to 4	Displays subnet currently available; <ul style="list-style-type: none"> • U6 -84: First octet • U6 -85: Second octet • U6 -86: Third octet • U6 -87: Forth octet 	0 to 255
U6-88 to U6-91	Online Gateway	Displays gateway currently available; <ul style="list-style-type: none"> • U6 -88: First octet • U6 -89: Second octet • U6 -90: Third octet • U6 -91: Forth octet 	0 to 255
U6-92	Online Speed	Displays CN1 Port 1 link speed currently available.	10: 10 Mbps 100: 100 Mbps
U6-93	Online Duplex	Displays CN1 Port 1 duplex setting currently available.	0: Half, 1: Full
U6-97	OPT SPARE 4	Displays option software version.	–
U6-98	First Fault	Displays first option fault. Refer to <i>Option Fault Monitors U6-98 and U6-99 on page 83</i> for details.	–
U6-99	Current Fault	Displays current option fault. Refer to <i>Option Fault Monitors U6-98 and U6-99 on page 83</i> for details.	–

7 Configuring Messaging

This section provides information on methods used to control the drive with the option installed.

◆ Drive Polled Configuration

The assemblies in [Table 9](#) are available for polled I/O:

Table 9 Supported Polled I/O Assemblies

Assembly Number (Hex)	Description	Type	Bytes	Page
20 (14)	Basic Speed Control Output	Output	4	30
21 (15)	Extended Speed Control Output	Output	4	30
22 (16)	Speed and Torque Control Output	Output	6	31
23 (17)	Extended Speed and Torque Control Output	Output	6	31
70 (46)	Basic Speed Control Input	Input	4	47
71 (47)	Extended Speed Control Input	Input	4	47
72 (48)	Speed and Torque Control Input	Input	6	48
73 (49)	Extended Speed and Torque Control Input	Input	6	49
100 (64)	(Vendor Specific Yaskawa Electric (YE) Assy)-MEMOBUS/Modbus Message Output	Output	5	32
101 (65)	(Vendor Specific Yaskawa Electric (YE) Assy)-Speed/Torque Control Output	Output	8	33
115 (73)	(Vendor Specific Yaskawa Electric (YE) Assy)-Extended Speed/Torque Control Output	Output	40	35
116 (74)	(Vendor Specific Yaskawa Electric (YE) Assy)-High Speed/Torque Control Output	Output	44	37
117 (75)	(Vendor Specific Yaskawa Electric (YE) Assy)-8 Byte Dynamic Output	Output	8	40
118 (76)	(Vendor Specific Yaskawa Electric (YE) Assy)-12 Byte Dynamic Output	Output	12	41
119 (77)	(Vendor Specific Yaskawa Electric (YE) Assy)-18 Byte Dynamic Output	Output	18	43
120 (78)	(Vendor Specific Yaskawa Electric (YE) Assy)-24 Byte Dynamic Output	Output	24	45
150 (96)	(Vendor Specific Yaskawa Electric (YE) Assy)-MEMOBUS/Modbus Message Input	Input	5	50
151 (97)	(Vendor Specific Yaskawa Electric (YE) Assy)-Speed/Torque Status Input	Input	8	51
155 (9B)	(Vendor Specific Yaskawa Electric (YE) Assy)- Extended Speed/ Torque Status Input	Input	40	53
166 (A6)	(Vendor Specific Yaskawa Electric (YE) Assy)-High Speed/Torque Status Input	Input	44	56
167 (A7)	(Vendor Specific Yaskawa Electric (YE) Assy)-8 Byte Dynamic Input	Input	8	60
168 (A8)	(Vendor Specific Yaskawa Electric (YE) Assy)-12 Byte Dynamic Input	Input	12	61
169 (A9)	(Vendor Specific Yaskawa Electric (YE) Assy)-18 Byte Dynamic Input	Input	18	63
170 (AA)	(Vendor Specific Yaskawa Electric (YE) Assy)-24 Byte Dynamic Input	Input	24	65

8 Output Assemblies (Drive Consumes)

Note: The convention in this manual is from the PLC perspective. As such, an assembly is called an “Output Assembly” when outputted from the PLC and received by this node. This section details “Output Assemblies” that are “Consumed” by this drive.

◆ Basic Speed Control Output - 20 (0x14)

Output Instance	Word	Byte	Bit 7	Bit 6	Bit 5	Bit 4	Bit 3	Bit 2	Bit 1	Bit 0	
20	0	0	–	–	–	–	–	Fault Reset	–	Run Fwd	
		1	–								
	1	2	Speed Reference (Low Byte)								
		3	Speed Reference (High Byte)								

Name	Description
Run Fwd	Forward Run Command 0: Stop 1: Forward Run
Fault Reset	Fault Reset (0 to 1 transition: Fault Reset)
Speed Reference	Speed Command Sets drive speed reference. Speed reference data: Frequency reference/2 ^{SS} (SS: Speed scale) Setting range: 0 to 0xFFFF Example: setting a reference of 4096 with a speed scale of 2: Speed reference data = 4096/2 ² = 1024 = 0x0400 Unit depends on o1-03.

◆ Extended Speed Control Output - 21 (0x15)

Output Instance	Word	Byte	Bit 7	Bit 6	Bit 5	Bit 4	Bit 3	Bit 2	Bit 1	Bit 0	
21	0	0	–	NetRef	NetCtrl	–	–	Fault Reset	Run Rev	Run Fwd	
		1	–								
	1	2	Speed Reference (Low Byte)								
		3	Speed Reference (High Byte)								

Name	Description
Run Fwd	Forward Run Command 0: Stop 1: Forward Run
Run Rev	Reverse Run Command 0: Stop 1: Reverse Run
Fault Reset	Fault Reset (0 to 1 transition: Fault Reset)
NetCtrl	Run command from Network 0: Depends on b1-02 1: Enables the run command from network
NetRef	Speed reference from Network 0: Depends on b1-01 1: Enables the speed reference from network
Speed Reference	Speed Command Sets drive speed reference. Speed reference data: Frequency reference/2 ^{SS} (SS: Speed scale) Setting range: 0 to 0xFFFF For example, when setting a reference of 4096 with a speed scale of 2: Speed reference data = 4096/2 ² = 1024 = 0x0400 Unit depends on o1-03.

◆ Speed and Torque Control Output - 22 (0x16)

Output Instance	Word	Byte	Bit 7	Bit 6	Bit 5	Bit 4	Bit 3	Bit 2	Bit 1	Bit 0	
22	0	0	–	–	–	–	–	Fault Reset	–	Run Fwd	
		1	–								
	1	2	Speed Reference (Low Byte)								
		3	Speed Reference (High Byte)								
	2	4	Torque Reference/Torque Limit (Low Byte)								
		5	Torque Reference/Torque Limit (High Byte)								

Name	Description
Run Fwd	Forward Run Command 0: Stop 1: Forward Run
Fault Reset	Fault Reset (0 to 1 transition: Fault Reset)
Speed Reference	Speed Command Sets drive speed reference. Speed reference data: Frequency reference/ 2^{SS} (SS: Speed scale) Setting range: 0 to 0xFFFF For example, when setting a reference of 4096 with a speed scale of 2: Speed reference data = $4096/2^2 = 1024 = 0x0400$ Unit depends on o1-03.
Torque Reference/Torque Limit	Torque Reference/Torque Limit Sets the Torque Reference/Torque Limit in units of 0.1%. Sets the Torque Reference when using Torque Control (d5-01 = 1). <I> Sets the Torque Limit when using Speed Control (d5-01 = 0). The Torque Reference and Torque Limit are disabled with F6-06 = 0.

<I> Torque Control is not available for GA500.

◆ Extended Speed and Torque Control Output - 23 (0x17)

Output Instance	Word	Byte	Bit 7	Bit 6	Bit 5	Bit 4	Bit 3	Bit 2	Bit 1	Bit 0	
23	0	0	–	NetRef	NetCtrl	–	–	Fault Reset	Run Rev	Run Fwd	
		1	–								
	1	2	Speed Reference (Low Byte)								
		3	Speed Reference (High Byte)								
	2	4	Torque Reference/Torque Limit (Low Byte)								
		5	Torque Reference/Torque Limit (High Byte)								

Name	Description
Run Fwd	Forward Run Command 0: Stop 1: Forward Run
Run Rev	Reverse Run Command 0: Stop 1: Reverse Run
Fault Reset	Fault Reset (0 to 1 transition: Fault Reset)
NetCtrl	Run command from Network 0: Depends on b1-02 1: Enables the run command from network
NetRef	Speed reference from Network 0: Depends on b1-01 1: Enables the speed reference from network

8 Output Assemblies (Drive Consumes)

Name	Description
Speed Reference	Speed Command Sets drive speed reference. Speed reference data: Frequency reference/2 ^{SS} (SS: Speed scale) Setting range: 0 to 0xFFFF For example, when setting a reference of 4096 with a speed scale of 2: Speed reference data = 4096/2 ² = 1024 = 0x0400 Unit depends on o1-03.
Torque Reference/Torque Limit	Torque Reference/Torque Limit Sets the Torque Reference/Torque Limit in units of 0.1%. Sets the Torque Reference when using Torque Control (d5-01 = 1). </> Sets the Torque Limit when using Speed Control (d5-01 = 0). The Torque Reference and Torque Limit are disabled with F6-06 = 0.

<1> Torque Control is not available for GA500.

◆ MEMOBUS/Modbus Message Output (Vendor Specific Yaskawa Electric (YE) Assy) - 100 (0x64)

Output Instance	Word	Byte	Bit 7	Bit 6	Bit 5	Bit 4	Bit 3	Bit 2	Bit 1	Bit 0
100	0	0	Function Code							
		1	Register Number (High Byte)							
	1	2	Register Number (Low Byte)							
		3	Register Data (High Byte)							
	2	4	Register Data (Low Byte)							

Note: This is a paired assembly (100/150).

Name	Description
Function Code	MEMOBUS/Modbus Function Code
Register Number	MEMOBUS/Modbus Register Number
Register Data	MEMOBUS/Modbus Register Data

Table 10 Function Code Decode Table

Function Code	MEMOBUS/Modbus Function
0x00	No Operation
0x03	Read Register
0x10	Write Register

Note: Refer to the MEMOBUS/Modbus Data Table in Appendix C of the Technical Manual for a list of monitor data using the MEMOBUS/Modbus message area.

◆ Speed/Torque Control Output (Vendor Specific Yaskawa Electric (YE) Assy) - 101 (0x65)

Output Instance	Word	Byte	Bit 7	Bit 6	Bit 5	Bit 4	Bit 3	Bit 2	Bit 1	Bit 0	
101	0	0	1000-Series Drives, GA700, and GA800: Multi-Function Input 8 GA500: –	Multi-Function Input 7	Multi-Function Input 6	Multi-Function Input 5	Multi-Function Input 4	Multi-Function Input 3	Run Rev	Run Fwd	
		1	Multi-Function Digital Output 3	Multi-Function Digital Output 2	Multi-Function Digital Output 1	–	–	–	Fault Reset	External Fault	
	1	2	Speed Reference (Low Byte)								
		3	Speed Reference (High Byte)								
	2	4	Torque Reference/Torque Limit (Low Byte)								
		5	Torque Reference/Torque Limit (High Byte)								
	3	6	Torque Compensation (Low Byte)								
		7	Torque Compensation (High Byte)								

Output Instance	Byte
Run Fwd	Forward Run Command 0: Stop 1: Forward Run
Run Rev	Reverse Run Command 0: Stop 1: Reverse Run
Multi-Function Input 3	Terminal S3 Function Input 0: Terminal S3 Function (H1-03) OFF 1: Terminal S3 Function (H1-03) ON
Multi-Function Input 4	Terminal S4 Function Input 0: Terminal S4 Function (H1-04) OFF 1: Terminal S4 Function (H1-04) ON
Multi-Function Input 5	Terminal S5 Function Input 0: Terminal S5 Function (H1-05) OFF 1: Terminal S5 Function (H1-05) ON
Multi-Function Input 6	Terminal S6 Function Input 0: Terminal S6 Function (H1-06) OFF 1: Terminal S6 Function (H1-06) ON
Multi-Function Input 7	Terminal S7 Function Input 0: Terminal S7 Function (H1-07) OFF 1: Terminal S7 Function (H1-07) ON
Multi-Function Input 8 </>	Terminal S8 Function Input 0: Terminal S8 Function (H1-08) OFF 1: Terminal S8 Function (H1-08) ON
External Fault	External Fault EF0 0: No External Fault (EF0) 1: External Fault (EF0)
Fault Reset	Fault Reset 0: No Fault Reset 1: Fault Reset

8 Output Assemblies (Drive Consumes)

Output Instance	Byte
Multi-Function Digital Output 1	<p>1000-Series Drives, GA700, and GA800: Terminal M1/M2 (varies by drive model) 0: M1/M2 OFF 1: M1/M2 ON This function is enabled only when H2-01 is set to F. Note: The names of the digital outputs are different for different drive series. GA500: Terminal MA/MB 0: MA/MB OFF 1: MA/MB ON This function is enabled only when H2-01 is set to F.</p>
Multi-Function Digital Output 2	<p>1000-Series Drives, GA700, and GA800: Terminal M3/M4 (varies by drive model) 0: M3/M4 OFF 1: M3/M4 ON This function is enabled only when H2-02 is set to F. Note: The names of the digital outputs are different for different drive series. GA500: Terminal P1 0: P1 OFF 1: P1 ON This function is enabled only when H2-02 is set to F.</p>
Multi-Function Digital Output 3	<p>1000-Series Drives, GA700, and GA800: Terminal M5/M6 (varies by drive model) 0: M5/M6 OFF 1: M5/M6 ON This function is enabled only when H2-03 is set to F. Note: The names of the digital outputs are different for different drive series. GA500: Terminal P2 0: P2 OFF 1: P2 ON This function is enabled only when H2-03 is set to F.</p>
Speed Reference	<p>Speed Command Sets drive speed reference. Unit depends on o1-03. Unit is not affected by Speed Scale SS.</p>
Torque Reference/Torque Limit	<p>Torque Reference/Torque Limit Sets the Torque Reference/Torque Limit in units of 0.1%. Sets the Torque Reference when using Torque Control (d5-01 = 1). <2> Sets the Torque Limit when using Speed Control (d5-01 = 0). The Torque Reference and Torque Limit are disabled with F6-06 = 0.</p>
Torque Compensation	<p>Sets the amount of Torque Compensation Sets in units of 0.1%.</p>

<1> GA500 does not have multi-function digital input 8.

<2> Torque Control is not available for GA500.

◆ Extended Speed/Torque Control Output (Vendor Specific Yaskawa Electric (YE) Assy) - 115 (0x73)

Output Instance	Word	Byte	Bit 7	Bit 6	Bit 5	Bit 4	Bit 3	Bit 2	Bit 1	Bit 0	
115	0	0	1000-Series Drives, GA700, and GA800: Multi-Function Input 8 GA500: –	Multi-Function Input 7	Multi-Function Input 6	Multi-Function Input 5	Multi-Function Input 4	Multi-Function Input 3	Run Rev	Run Fwd	
		1	Multi-Function Digital Output 3	Multi-Function Digital Output 2	Multi-Function Digital Output 1	–	–	–	Fault Reset	External Fault	
	1	2	Speed Reference (Low Byte)								
		3	Speed Reference (High Byte)								
	2	4	Torque Reference/Torque Limit (Low Byte)								
		5	Torque Reference/Torque Limit (High Byte)								
	3	6	Torque Compensation (Low Byte)								
		7	Torque Compensation (High Byte)								
	4 - 5	8 - 11	Reserved								
	6	12	Analog Output 1 (Low Byte)								
		13	Analog Output 1 (High Byte)								
	7	14	Analog Output 2 (Low Byte) <1>								
		15	Analog Output 2 (High Byte) <1>								
	8	16	Digital Outputs (Low Byte)								
		17	Digital Outputs (High Byte)								
	9 - 19	18 - 39	Reserved								

<1> GA500 does not have Analog Output 2.

Parameter	Data
Run Fwd	Forward Run Command 0: Stop 1: Forward Run
Run Rev	Reverse Run Command 0: Stop 1: Reverse Run
Multi-Function Input 3	Terminal S3 Function Input 0: Terminal S3 Function (H1-03) OFF 1: Terminal S3 Function (H1-03) ON
Multi-Function Input 4	Terminal S4 Function Input 0: Terminal S4 Function (H1-04) OFF 1: Terminal S4 Function (H1-04) ON
Multi-Function Input 5	Terminal S5 Function Input 0: Terminal S5 Function (H1-05) OFF 1: Terminal S5 Function (H1-05) ON
Multi-Function Input 6	Terminal S6 Function Input 0: Terminal S6 Function (H1-06) OFF 1: Terminal S6 Function (H1-06) ON
Multi-Function Input 7	Terminal S7 Function Input 0: Terminal S7 Function (H1-07) OFF 1: Terminal S7 Function (H1-07) ON
Multi-Function Input 8 <1>	Terminal S8 Function Input 0: Terminal S8 Function (H1-08) OFF 1: Terminal S8 Function (H1-08) ON

8 Output Assemblies (Drive Consumes)

Parameter	Data
External Fault	External Fault EF0 0: No External Fault (EF0) 1: External Fault (EF0)
Fault Reset	Fault Reset 0: No Fault Reset 1: Fault Reset
Multi-Function Digital Output 1	1000-Series Drives, GA700, and GA800: Terminal M1/M2 (varies by drive model) 0: M1/M2 OFF 1: M1/M2 ON This function is enabled only when H2-01 is set to F. Note: The names of the digital outputs are different for different drive series. GA500: Terminal MA/MB 0: MA/MB OFF 1: MA/MB ON This function is enabled only when H2-01 is set to F.
Multi-Function Digital Output 2	1000-Series Drives, GA700, and GA800: Terminal M3/M4 (varies by drive model) 0: M3/M4 OFF 1: M3/M4 ON This function is enabled only when H2-02 is set to F. Note: The names of the digital outputs are different for different drive series. GA500: Terminal P1 0: P1 OFF 1: P1 ON This function is enabled only when H2-02 is set to F.
Multi-Function Digital Output 3	1000-Series Drives, GA700, and GA800: Terminal M5/M6 (varies by drive model) 0: M5/M6 OFF 1: M5/M6 ON This function is enabled only when H2-03 is set to F. Note: The names of the digital outputs are different for different drive series. GA500: Terminal P2 0: P2 OFF 1: P2 ON This function is enabled only when H2-03 is set to F.
Speed Reference	Speed Reference [RPM or 01-03]
Torque Reference/Torque Limit	Torque Reference/Torque Limit Sets the Torque Reference/Torque Limit in units of 0.1%. Sets the Torque Reference when using Torque Control (d5-01 = 1). <2> Sets the Torque Limit when using Speed Control (d5-01 = 0). The Torque Reference and Torque Limit are disabled with F6-06 = 0.
Torque Compensation	Sets the amount of Torque Compensation Sets in units of 0.1%.
Analog Output 1	MEMOBUS/Modbus (0x0007)
Analog Output 2 <3>	MEMOBUS/Modbus (0x0008)
Digital Outputs	MEMOBUS/Modbus (0x0009) Note: These values are ORed with values in byte 1.

<1> GA500 does not have multi-function digital input 8.

<2> Torque Control is not available for GA500.

<3> GA500 does not have Analog Output 2.

◆ High Speed/Torque Control Output (Vendor Specific Yaskawa Electric (YE) Assy) - 116 (0x74)

This assembly is dynamic and can be configured as to what parameters are used. The first 20 Bytes (0-19) are fixed and the next 20 Bytes can be configured using parameters F7-23 to F7-32. If an error occurs while trying to write to the dynamic parameters, the appropriate error bit in Assembly 166 will be set. If more information is needed as to the nature of the error, the extended error status can be read explicitly through Class 4, Instance 0xA6, Attribute 0x64. This will return 20 Bytes with each dynamic parameter in Assembly 116 having a Byte dedicated to its extended error status. [Refer to Input Assemblies \(Drive Produces\) on page 47](#) for more information.

Output Instance	Word	Byte	Bit 7	Bit 6	Bit 5	Bit 4	Bit 3	Bit 2	Bit 1	Bit 0	
116	0	0	1000-Series Drives, GA700, and GA800: Multi-Function Input 8 GA500: –	Multi-Function Input 7	Multi-Function Input 6	Multi-Function Input 5	Multi-Function Input 4	Multi-Function Input 3	Run Rev	Run Fwd	
		1	Multi-Function Digital Output 3	Multi-Function Digital Output 2	Multi-Function Digital Output 1	–	–	–	Fault Reset	External Fault	
	1	2	Speed Reference (Low Byte)								
		3	Speed Reference (High Byte)								
	2	4	Torque Reference/Torque Limit (Low Byte)								
		5	Torque Reference/Torque Limit (High Byte)								
	3	6	Torque Compensation (Low Byte)								
		7	Torque Compensation (High Byte)								
	4	8	Reserved								
		9	–	–	–	–	Multi-Function Input 12	Multi-Function Input 11	Multi-Function Input 10	Multi-Function Input 9	
	5	10	–	–	–	–	–	–	NetCtrl	NetRef	
		11	–	–	–	–	–	–	–	–	
	6	12	Analog Output 1 (Low Byte)								
		13	Analog Output 1 (High Byte)								
	7	14	Analog Output 2 (Low Byte) <I>								
		15	Analog Output 2 (High Byte) <I>								
	8	16	Digital Outputs (Low Byte)								
		17	Digital Outputs (High Byte)								
	9	18	Reserved								
		19	Reserved								
	10	20 - 21	Dynamic Output 1 Defined by F7-23 Default: Not Used								
	11	22 - 23	Dynamic Output 2 Defined by F7-24 Default: Not Used								
	12	24 - 25	Dynamic Output 3 Defined by F7-25 Default: Not Used								
	13	26 - 27	Dynamic Output 4 Defined by F7-26 Default: Not Used								
	14	28 - 29	Dynamic Output 5 Defined by F7-27 Default: Not Used								

8 Output Assemblies (Drive Consumes)

Output Instance	Word	Byte	Bit 7	Bit 6	Bit 5	Bit 4	Bit 3	Bit 2	Bit 1	Bit 0
116	15	30 - 31	Dynamic Output 6 Defined by F7-28 Default: Not Used							
	16	32 - 33	Dynamic Output 7 Defined by F7-29 Default: Not Used							
	17	34 - 35	Dynamic Output 8 Defined by F7-30 Default: Not Used							
	18	36 - 37	Dynamic Output 9 Defined by F7-31 Default: Not Used							
	19	38 - 39	Dynamic Output 10 Defined by F7-32 Default: Not Used							
	20 - 21	40 - 43	Not Used							

<1> GA500 does not have Analog Output 2.

Parameter	Data
Run Fwd	Forward Run Command 0: Stop 1: Forward Run
Run Rev	Reverse Run Command 0: Stop 1: Reverse Run
Multi-Function Input 3	Terminal S3 Function Input 0: Terminal S3 Function (H1-03) OFF 1: Terminal S3 Function (H1-03) ON
Multi-Function Input 4	Terminal S4 Function Input 0: Terminal S4 Function (H1-04) OFF 1: Terminal S4 Function (H1-04) ON
Multi-Function Input 5	Terminal S5 Function Input 0: Terminal S5 Function (H1-05) OFF 1: Terminal S5 Function (H1-05) ON
Multi-Function Input 6	Terminal S6 Function Input 0: Terminal S6 Function (H1-06) OFF 1: Terminal S6 Function (H1-06) ON
Multi-Function Input 7	Terminal S7 Function Input 0: Terminal S7 Function (H1-07) OFF 1: Terminal S7 Function (H1-07) ON
Multi-Function Input 8 <1>	Terminal S8 Function Input 0: Terminal S8 Function (H1-08) OFF 1: Terminal S8 Function (H1-08) ON
External Fault	External Fault EF0 0: No External Fault (EF0) 1: External Fault (EF0)
Fault Reset	Fault Reset 0: No Fault Reset 1: Fault Reset
Multi-Function Digital Output 1	1000-Series Drives, GA700, and GA800: Terminal M1/M2 (varies by drive model) 0: M1/M2 OFF 1: M1/M2 ON This function is enabled only when H2-01 is set to F. Note: The names of the digital outputs are different for different drive series. GA500: Terminal MA/MB 0: MA/MB OFF 1: MA/MB ON This function is enabled only when H2-01 is set to F.

Parameter	Data
Multi-Function Digital Output 2	1000-Series Drives, GA700, and GA800: Terminal M3/M4 (varies by drive model) 0: M3/M4 OFF 1: M3/M4 ON This function is enabled only when H2-02 is set to F. Note: The names of the digital outputs are different for different drive series. GA500: Terminal P1 0: P1 OFF 1: P1 ON This function is enabled only when H2-02 is set to F.
Multi-Function Digital Output 3	1000-Series Drives, GA700, and GA800: Terminal M5/M6 (varies by drive model) 0: M5/M6 OFF 1: M5/M6 ON This function is enabled only when H2-03 is set to F. Note: The names of the digital outputs are different for different drive series. GA500: Terminal P2 0: P2 OFF 1: P2 ON This function is enabled only when H2-03 is set to F.
Speed Reference	Speed Reference [RPM or o1-03]
Torque Reference/Torque Limit	Torque Reference/Torque Limit Sets the Torque Reference/Torque Limit in units of 0.1%. Sets the Torque Reference when using Torque Control (d5-01 = 1). <2> Sets the Torque Limit when using Speed Control (d5-01 = 0). The Torque Reference and Torque Limit are disabled with F6-06 = 0.
Torque Compensation	Sets the amount of Torque Compensation Sets in units of 0.1%.
Digital Inputs	Sets digital inputs 9-12 if the drive supports them.
NetRef	Network sets reference
NetCtrl	Network sets control
Analog Output 1	MEMOBUS/Modbus (0x0007)
Analog Output 2 <3>	MEMOBUS/Modbus (0x0008)
Digital Outputs	MEMOBUS/Modbus (0x0009) Note: These values are ORed with values in byte 1.
Dynamic Outputs	Contains the data to be written to the MEMOBUS/Modbus address defined in the given parameter. A value of 0 in the given parameter means it is not used, therefore the value received for this given parameter will not be written to any MEMOBUS/Modbus register. If the PPA is Input Assembly 166, then any errors occurring during a write will be flagged. <i>Refer to High Speed/Torque Status Input (Vendor Specific Yaskawa Electric (YE) Assy) - 166 (0xA6) on page 56</i> for details.

<1> GA500 does not have multi-function digital input 8.

<2> Torque Control is not available for GA500.

<3> GA500 does not have Analog Output 2.

◆ 8-Byte Dynamic Output 117 (0x75)

Output Instance	Word	Byte	Bit 7	Bit 6	Bit 5	Bit 4	Bit 3	Bit 2	Bit 1	Bit 0	
117	0	0	1000-Series Drives, GA700, and GA800: Multi-Function Input 8 GA500: –	Multi-Function Input 7	Multi-Function Input 6	Multi-Function Input 5	Multi-Function Input 4	Multi-Function Input 3	Run Rev	Run Fwd	
		1	Output 3	Output 2	Output 1	–	–	–	Fault Reset	External Fault	
	1	2	Speed Reference (Low Byte)								
		3	Speed Reference (High Byte)								
	2	4-5	Dynamic Output 1 (F7-23) Default: Not Used								
	3	6-7	Dynamic Output 2 (F7-24) Default: Not Used								

Name	Description
Run Fwd	Forward Run Command 0: Stop 1: Forward Run
Run Rev	Reverse Run Command 0: Stop 1: Reverse Run
Multi-Function Input 3	Terminal S3 Function Input 0: Terminal S3 Function (H1-03) OFF 1: Terminal S3 Function (H1-03) ON
Multi-Function Input 4	Terminal S4 Function Input 0: Terminal S4 Function (H1-04) OFF 1: Terminal S4 Function (H1-04) ON
Multi-Function Input 5	Terminal S5 Function Input 0: Terminal S5 Function (H1-05) OFF 1: Terminal S5 Function (H1-05) ON
Multi-Function Input 6	Terminal S6 Function Input 0: Terminal S6 Function (H1-06) OFF 1: Terminal S6 Function (H1-06) ON
Multi-Function Input 7	Terminal S7 Function Input 0: Terminal S7 Function (H1-07) OFF 1: Terminal S7 Function (H1-07) ON
Multi-Function Input 8 </>	Terminal S8 Function Input 0: Terminal S8 Function (H1-08) OFF 1: Terminal S8 Function (H1-08) ON
External Fault	External Fault EF0 0: No External Fault (EF0) 1: External Fault (EF0)
Fault Reset	Fault Reset 0: No Fault Reset 1: Fault Reset
Multi-Function Digital Output 1	1000-Series Drives, GA700, and GA800: Terminal M1/M2 (varies by drive model) 0: M1/M2 OFF 1: M1/M2 ON This function is enabled only when H2-01 is set to F. Note: The names of the digital outputs are different for different drive series. GA500: Terminal MA/MB 0: MA/MB OFF 1: MA/MB ON This function is enabled only when H2-01 is set to F.

Name	Description
Multi-Function Digital Output 2	1000-Series Drives, GA700, and GA800: Terminal M3/M4 (varies by drive model) 0: M3/M4 OFF 1: M3/M4 ON This function is enabled only when H2-02 is set to F. Note: The names of the digital outputs are different for different drive series. GA500: Terminal P1 0: P1 OFF 1: P1 ON This function is enabled only when H2-02 is set to F.
Multi-Function Digital Output 3	1000-Series Drives, GA700, and GA800: Terminal M5/M6 (varies by drive model) 0: M5/M6 OFF 1: M5/M6 ON This function is enabled only when H2-03 is set to F. Note: The names of the digital outputs are different for different drive series. GA500: Terminal P2 0: P2 OFF 1: P2 ON This function is enabled only when H2-03 is set to F.
Speed Reference	Speed Command Sets drive speed reference. Unit depends on o1-03. Unit is not affected by Speed Scale SS.
Dynamic Outputs	Contains the data to be written to the MEMOBUS/Modbus address defined in the given parameter. A value of 0 in the given parameter means it is not used, therefore the value received for this given parameter will not be written to any MEMOBUS/Modbus register. If the PPA is Input Assembly 166, then any errors occurring during a write will be flagged. <i>Refer to High Speed/Torque Status Input (Vendor Specific Yaskawa Electric (YE) Assy) - 166 (0xA6) on page 56</i> for details.

<1> GA500 does not have multi-function digital input 8.

◆ 12-Byte Dynamic Output 118 (0x76)

Output Instance	Word	Byte	Bit 7	Bit 6	Bit 5	Bit 4	Bit 3	Bit 2	Bit 1	Bit 0	
118	0	0	1000-Series Drives, GA700, and GA800: Multi-Function Input 8 GA500: –	Multi-Function Input 7	Multi-Function Input 6	Multi-Function Input 5	Multi-Function Input 4	Multi-Function Input 3	Run Rev	Run Fwd	
		1	Output 3	Output 2	Output 1	–	–	–	Fault Reset	External Fault	
	1	2	Speed Reference (Low Byte)								
		3	Speed Reference (High Byte)								
	2	4-5	Dynamic Output 1 (F7-23) Default: Not Used								
	3	6-7	Dynamic Output 2 (F7-24) Default: Not Used								
	4	8-9	Dynamic Output 3 (F7-25) Default: Not Used								
5	10-11	Dynamic Output 4 (F7-26) Default: Not Used									

Name	Description
Run Fwd	Forward Run Command 0: Stop 1: Forward Run
Run Rev	Reverse Run Command 0: Stop 1: Reverse Run

8 Output Assemblies (Drive Consumes)

Name	Description
Multi-Function Input 3	Terminal S3 Function Input 0: Terminal S3 Function (H1-03) OFF 1: Terminal S3 Function (H1-03) ON
Multi-Function Input 4	Terminal S4 Function Input 0: Terminal S4 Function (H1-04) OFF 1: Terminal S4 Function (H1-04) ON
Multi-Function Input 5	Terminal S5 Function Input 0: Terminal S5 Function (H1-05) OFF 1: Terminal S5 Function (H1-05) ON
Multi-Function Input 6	Terminal S6 Function Input 0: Terminal S6 Function (H1-06) OFF 1: Terminal S6 Function (H1-06) ON
Multi-Function Input 7	Terminal S7 Function Input 0: Terminal S7 Function (H1-07) OFF 1: Terminal S7 Function (H1-07) ON
Multi-Function Input 8 </>	Terminal S8 Function Input 0: Terminal S8 Function (H1-08) OFF 1: Terminal S8 Function (H1-08) ON
External Fault	External Fault EF0 0: No External Fault (EF0) 1: External Fault (EF0)
Fault Reset	Fault Reset 0: No Fault Reset 1: Fault Reset
Multi-Function Digital Output 1	1000-Series Drives, GA700, and GA800: Terminal M1/M2 (varies by drive model) 0: M1/M2 OFF 1: M1/M2 ON This function is enabled only when H2-01 is set to F. Note: The names of the digital outputs are different for different drive series. GA500: Terminal MA/MB 0: MA/MB OFF 1: MA/MB ON This function is enabled only when H2-01 is set to F.
Multi-Function Digital Output 2	1000-Series Drives, GA700, and GA800: Terminal M3/M4 (varies by drive model) 0: M3/M4 OFF 1: M3/M4 ON This function is enabled only when H2-02 is set to F. Note: The names of the digital outputs are different for different drive series. GA500: Terminal P1 0: P1 OFF 1: P1 ON This function is enabled only when H2-02 is set to F.
Multi-Function Digital Output 3	1000-Series Drives, GA700, and GA800: Terminal M5/M6 (varies by drive model) 0: M5/M6 OFF 1: M5/M6 ON This function is enabled only when H2-03 is set to F. Note: The names of the digital outputs are different for different drive series. GA500: Terminal P2 0: P2 OFF 1: P2 ON This function is enabled only when H2-03 is set to F.
Speed Reference	Speed Command Sets drive speed reference. Unit depends on o1-03. Unit is not affected by Speed Scale SS.

Name	Description
Dynamic Outputs	Contains the data to be written to the MEMOBUS/Modbus address defined in the given parameter. A value of 0 in the given parameter means it is not used, therefore the value received for this given parameter will not be written to any MEMOBUS/Modbus register. If the PPA is Input Assembly 166, then any errors occurring during a write will be flagged. <i>Refer to High Speed/Torque Status Input (Vendor Specific Yaskawa Electric (YE) Assy) - 166 (0xA6) on page 56</i> for details.

<1> GA500 does not have multi-function digital input 8.

◆ 18-Byte Dynamic Output 119 (0x77)

Output Instance	Word	Byte	Bit 7	Bit 6	Bit 5	Bit 4	Bit 3	Bit 2	Bit 1	Bit 0	
119	0	0	1000-Series Drives, GA700, and GA800: Multi-Function Input 8 GA500: –	Multi-Function Input 7	Multi-Function Input 6	Multi-Function Input 5	Multi-Function Input 4	Multi-Function Input 3	Run Rev	Run Fwd	
		1	Output 3	Output 2	Output 1	–	–	–	Fault Reset	External Fault	
	1	2	Speed Reference (Low Byte)								
		3	Speed Reference (High Byte)								
	2	4-5	Dynamic Output 1 (F7-23) Default: Not Used								
	3	6-7	Dynamic Output 2 (F7-24) Default: Not Used								
	4	8-9	Dynamic Output 3 (F7-25) Default: Not Used								
	5	10-11	Dynamic Output 4 (F7-26) Default: Not Used								
	6	12-13	Dynamic Output 5 (F7-27) Default: Not Used								
	7	14-15	Dynamic Output 6 (F7-28) Default: Not Used								
8	16-17	Dynamic Output 7 (F7-29) Default: Not Used									

Name	Description
Run Fwd	Forward Run Command 0: Stop 1: Forward Run
Run Rev	Reverse Run Command 0: Stop 1: Reverse Run
Multi-Function Input 3	Terminal S3 Function Input 0: Terminal S3 Function (H1-03) OFF 1: Terminal S3 Function (H1-03) ON
Multi-Function Input 4	Terminal S4 Function Input 0: Terminal S4 Function (H1-04) OFF 1: Terminal S4 Function (H1-04) ON
Multi-Function Input 5	Terminal S5 Function Input 0: Terminal S5 Function (H1-05) OFF 1: Terminal S5 Function (H1-05) ON
Multi-Function Input 6	Terminal S6 Function Input 0: Terminal S6 Function (H1-06) OFF 1: Terminal S6 Function (H1-06) ON
Multi-Function Input 7	Terminal S7 Function Input 0: Terminal S7 Function (H1-07) OFF 1: Terminal S7 Function (H1-07) ON
Multi-Function Input 8 </>	Terminal S8 Function Input 0: Terminal S8 Function (H1-08) OFF 1: Terminal S8 Function (H1-08) ON
External Fault	External Fault EF0 0: No External Fault (EF0) 1: External Fault (EF0)

8 Output Assemblies (Drive Consumes)

Name	Description
Fault Reset	Fault Reset 0: No Fault Reset 1: Fault Reset
Multi-Function Digital Output 1	1000-Series Drives, GA700, and GA800: Terminal M1/M2 (varies by drive model) 0: M1/M2 OFF 1: M1/M2 ON This function is enabled only when H2-01 is set to F. Note: The names of the digital outputs are different for different drive series. GA500: Terminal MA/MB 0: MA/MB OFF 1: MA/MB ON This function is enabled only when H2-01 is set to F.
Multi-Function Digital Output 2	1000-Series Drives, GA700, and GA800: Terminal M3/M4 (varies by drive model) 0: M3/M4 OFF 1: M3/M4 ON This function is enabled only when H2-02 is set to F. Note: The names of the digital outputs are different for different drive series. GA500: Terminal P1 0: P1 OFF 1: P1 ON This function is enabled only when H2-02 is set to F.
Multi-Function Digital Output 3	1000-Series Drives, GA700, and GA800: Terminal M5/M6 (varies by drive model) 0: M5/M6 OFF 1: M5/M6 ON This function is enabled only when H2-03 is set to F. Note: The names of the digital outputs are different for different drive series. GA500: Terminal P2 0: P2 OFF 1: P2 ON This function is enabled only when H2-03 is set to F.
Speed Reference	Speed Command Sets drive speed reference. Unit depends on o1-03. Unit is not affected by Speed Scale SS.
Dynamic Outputs	Contains the data to be written to the MEMOBUS/Modbus address defined in the given parameter. A value of 0 in the given parameter means it is not used, therefore the value received for this given parameter will not be written to any MEMOBUS/Modbus register. If the PPA is Input Assembly 166, then any errors occurring during a write will be flagged. <i>Refer to High Speed/Torque Status Input (Vendor Specific Yaskawa Electric (YE) Assy) - 166 (0xA6) on page 56</i> for details.

<1> GA500 does not have multi-function digital input 8.

◆ 24-Byte Dynamic Output 120 (0x78)

Output Instance	Word	Byte	Bit 7	Bit 6	Bit 5	Bit 4	Bit 3	Bit 2	Bit 1	Bit 0	
120	0	0	1000-Series Drives, GA700, and GA800: Multi-Function Input 8 GA500: –	Multi-Function Input 7	Multi-Function Input 6	Multi-Function Input 5	Multi-Function Input 4	Multi-Function Input 3	Run Rev	Run Fwd	
		1	Output 3	Output 2	Output 1	–	–	–	Fault Reset	External Fault	
	1	2	Speed Reference (Low Byte)								
		3	Speed Reference (High Byte)								
	2	4-5	Dynamic Output 1 (F7-23) Default: Not Used								
	3	6-7	Dynamic Output 2 (F7-24) Default: Not Used								
	4	8-9	Dynamic Output 3 (F7-25) Default: Not Used								
	5	10-11	Dynamic Output 4 (F7-26) Default: Not Used								
	6	12-13	Dynamic Output 5 (F7-27) Default: Not Used								
	7	14-15	Dynamic Output 6 (F7-28) Default: Not Used								
	8	16-17	Dynamic Output 7 (F7-29) Default: Not Used								
	9	18-19	Dynamic Output 8 (F7-30) Default: Not Used								
10	20-21	Dynamic Output 9 (F7-31) Default: Not Used									
11	22-23	Dynamic Output 10 (F7-32) Default: Not Used									

Name	Description
Run Fwd	Forward Run Command 0: Stop 1: Forward Run
Run Rev	Reverse Run Command 0: Stop 1: Reverse Run
Multi-Function Input 3	Terminal S3 Function Input 0: Terminal S3 Function (H1-03) OFF 1: Terminal S3 Function (H1-03) ON
Multi-Function Input 4	Terminal S4 Function Input 0: Terminal S4 Function (H1-04) OFF 1: Terminal S4 Function (H1-04) ON
Multi-Function Input 5	Terminal S5 Function Input 0: Terminal S5 Function (H1-05) OFF 1: Terminal S5 Function (H1-05) ON
Multi-Function Input 6	Terminal S6 Function Input 0: Terminal S6 Function (H1-06) OFF 1: Terminal S6 Function (H1-06) ON
Multi-Function Input 7	Terminal S7 Function Input 0: Terminal S7 Function (H1-07) OFF 1: Terminal S7 Function (H1-07) ON
Multi-Function Input 8 <I>	Terminal S8 Function Input 0: Terminal S8 Function (H1-08) OFF 1: Terminal S8 Function (H1-08) ON
External Fault	External Fault EF0 0: No External Fault (EF0) 1: External Fault (EF0)
Fault Reset	Fault Reset 0: No Fault Reset 1: Fault Reset

8 Output Assemblies (Drive Consumes)

Name	Description
Multi-Function Digital Output 1	1000-Series Drives, GA700, and GA800: Terminal M1/M2 (varies by drive model) 0: M1/M2 OFF 1: M1/M2 ON This function is enabled only when H2-01 is set to F. Note: The names of the digital outputs are different for different drive series. GA500: Terminal MA/MB 0: MA/MB OFF 1: MA/MB ON This function is enabled only when H2-01 is set to F.
Multi-Function Digital Output 2	1000-Series Drives, GA700, and GA800: Terminal M3/M4 (varies by drive model) 0: M3/M4 OFF 1: M3/M4 ON This function is enabled only when H2-02 is set to F. Note: The names of the digital outputs are different for different drive series. GA500: Terminal P1 0: P1 OFF 1: P1 ON This function is enabled only when H2-02 is set to F.
Multi-Function Digital Output 3	1000-Series Drives, GA700, and GA800: Terminal M5/M6 (varies by drive model) 0: M5/M6 OFF 1: M5/M6 ON This function is enabled only when H2-03 is set to F. Note: The names of the digital outputs are different for different drive series. GA500: Terminal P2 0: P2 OFF 1: P2 ON This function is enabled only when H2-03 is set to F.
Speed Reference	Speed Command Sets drive speed reference. Unit depends on o1-03. Unit is not affected by Speed Scale SS.
Dynamic Outputs	Contains the data to be written to the MEMOBUS/Modbus address defined in the given parameter. A value of 0 in the given parameter means it is not used, therefore the value received for this given parameter will not be written to any MEMOBUS/Modbus register. If the PPA is Input Assembly 166, then any errors occurring during a write will be flagged. <i>Refer to High Speed/Torque Status Input (Vendor Specific Yaskawa Electric (YE) Assy) - 166 (0xA6) on page 56</i> for details.

<1> GA500 does not have multi-function digital input 8.

9 Input Assemblies (Drive Produces)

Note: The convention in this manual is from the PLC perspective. An “Input Assembly” is outputted from this node and read by the PLC. This section details “Input Assemblies” that are “Produced” by this drive.

◆ Basic Speed Control Input - 70 (0x46)

Input Instance	Word	Byte	Bit 7	Bit 6	Bit 5	Bit 4	Bit 3	Bit 2	Bit 1	Bit 0	
70	0	0	–	–	–	–	–	Running 1 (FWD)	–	Faulted	
		1	–								
	1	2	Speed Actual (Low Byte)								
		3	Speed Actual (High Byte)								

Parameter	Data
Faulted	Faulted 0: No Faults Occurred 1: Fault Occurred
Running 1 (FWD)	Forward Running 0: Stop or Reverse Running 1: Forward Running
Speed Actual	Actual Drive Speed Monitors drive output frequency. Speed actual data: Output frequency x 2 ^{SS} (SS: Speed scale) Range: 0 to 0xFFFF For example, when output frequency of 1024 with a speed scale of 2: Speed actual data = 1024 x 2 ² = 4096 = 0x1000 Unit depends on o1-03.

◆ Extended Speed Control Input - 71 (0x47)

Input Instance	Word	Byte	Bit 7	Bit 6	Bit 5	Bit 4	Bit 3	Bit 2	Bit 1	Bit 0	
71	0	0	At Speed	Ref from Net	Ctrl from Net	Ready	Running 2 (REV)	Running 1 (FWD)	Warning	Faulted	
		1	Drive State								
	1	2	Speed Actual (Low Byte)								
		3	Speed Actual (High Byte)								

Name	Description
Faulted	Faulted 0: No Faults Occurred 1: Fault Occurred
Warning	Warning 0: No Warning Occurred 1: Warning Occurred
Running 1 (FWD)	Forward Running 0: Stop or Reverse Running 1: Forward Running
Running 2 (REV)	Reverse Running 0: Stop or Forward Running 1: Reverse Running
Ready	Drive Ready 0: Not Ready 1: Ready
Ctrl from Net	Status of Run command from Network 0: Run command is not from network 1: Run command is from network

9 Input Assemblies (Drive Produces)

Name	Description
Ref from Net	Status of Speed reference from Network 0: Speed reference is not from network 1: Speed reference is from network
At Speed	Speed Agree 0: No Speed Agree 1: Speed actual at speed reference
Drive State	Contains the value from the Control Supervisor (Class 0x29) Instance 1 Attribute 6.
Speed Actual	Actual Drive Speed Monitors drive output frequency. Speed actual data: Output frequency x 2 ^{SS} (SS: Speed scale) Range: 0 to 0xFFFF For example, when output frequency of 1024 with a speed scale of 2: Speed actual data = 1024 x 2 ² = 4096 = 0x1000 Unit depends on o1-03.

◆ Speed and Torque Control Input - 72 (0x48)

Input Instance	Word	Byte	Bit 7	Bit 6	Bit 5	Bit 4	Bit 3	Bit 2	Bit 1	Bit 0	
72	0	0	–	–	–	–	–	Running 1 (FWD)	–	Faulted	
		1	–								
	1	2	Speed Actual (Low Byte)								
		3	Speed Actual (High Byte)								
	2	4	Torque Actual (Low Byte)								
		5	Torque Actual (High Byte)								

Name	Description
Faulted	Faulted 0: No Faults Occurred 1: Fault Occurred
Running 1 (FWD)	Forward Running 0: Stop or Reverse Running 1: Forward Running
Speed Actual	Actual Drive Speed Monitors drive output frequency. Speed actual data: Output frequency x 2 ^{SS} (SS: Speed scale) Range: 0 to 0xFFFF For example, when output frequency of 1024 with a speed scale of 2: Speed actual data = 1024 x 2 ² = 4096 = 0x1000 Unit depends on o1-03.
Torque Actual	Output Torque Shows the Torque Reference. Value displays in 0.1% units.

◆ Extended Speed and Torque Control Input - 73 (0x49)

Input Instance	Word	Byte	Bit 7	Bit 6	Bit 5	Bit 4	Bit 3	Bit 2	Bit 1	Bit 0	
73	0	0	At Speed	Ref from Net	Ctrl from Net	Ready	Running 2 (REV)	Running 1 (FWD)	Warning	Faulted	
		1	Drive State								
	1	2	Speed Actual (Low Byte)								
		3	Speed Actual (High Byte)								
	2	4	Torque Actual (Low Byte)								
		5	Torque Actual (High Byte)								

Name	Description
Faulted	Faulted 0: No Faults Occurred 1: Fault Occurred
Warning	Warning 0: No Warning Occurred 1: Warning Occurred
Running 1 (FWD)	Forward Running 0: Stop or Reverse Running 1: Forward Running
Running 2 (REV)	Reverse Running 0: Stop or Forward Running 1: Reverse Running
Ready	Drive Ready 0: Not Ready 1: Ready
Ctrl from Net	Status of Run command from Network 0: Run command is not from network 1: Run command is from network
Ref from Net	Status of Speed reference from Network 0: Speed reference is not from network 1: Speed reference is from network
At Speed	Speed Agree 0: No Speed Agree 1: Speed actual at speed reference
Drive State	Contains the value from the Control Supervisor (Class 0x29) Instance 1 Attribute 6.
Speed Actual	Actual Drive Speed Monitors drive output frequency. Speed actual data: Output frequency x 2 ^{SS} (SS: Speed scale) Range: 0 to 0xFFFF For example, when output frequency of 1024 with a speed scale of 2: Speed actual data = 1024 x 2 ² = 4096 = 0x1000 Unit depends on o1-03.
Torque Actual	Output Torque Shows the Torque Reference. Value displays in 0.1% units.

◆ MEMOBUS/Modbus Message Input (Vendor Specific Yaskawa Electric (YE) Assy) - 150 (0x96)

Input Instance	Word	Byte	Bit 7	Bit 6	Bit 5	Bit 4	Bit 3	Bit 2	Bit 1	Bit 0
150	0	0	Function Code							
		1	Register Number (High Byte)							
	1	2	Register Number (Low Byte)							
		3	Register Data (High Byte)							
	2	4	Register Data (Low Byte)							

Note: This is a paired assembly (100/150).

Table 11 Reply Mapping - 150

Byte	Write Success	Read Success	Write Failure	Read Failure	Invalid Function Code	Function Code Equals Zero
0	0x10	0x03	0x90	0x83	Function Code Or-ed with 0x80	0
1	Output Assembly Register Number (High Byte)	Output Assembly Register Number (High Byte)	Output Assembly Register Number (High Byte)	Output Assembly Register Number (High Byte)	Output Assembly Register Number (High Byte)	0
2	Output Assembly Register Number (Low Byte)	Output Assembly Register Number (Low Byte)	Output Assembly Register Number (Low Byte)	Output Assembly Register Number (Low Byte)	Output Assembly Register Number (Low Byte)	0
3	0	Read Data (High Byte)	0	0	0	0
4	0	Read Data (Low Byte)	Error Code	Error Code	1	0

Table 12 Error Replies - 150

Error Code	Description
0x01	Invalid Function Code
0x02	Invalid Register Number
0x21	Upper/Lower Limit Error
0x22	Option generated busy event. The MEMOBUS/Modbus requested operation is in the process loop but the drive is not done yet. Writing "Enter" when drive is running. Attempt to write data that is read only. Attempt to write a parameter when drive is running. During a CPF03 event attempting to write to registers other than A1-00 to A1-05, E1-03, o2-04.
0x23	Attempting to write during a drive undervoltage (Uv) event.
0x24	Attempting to write while the drive is storing data.

Note: Refer to the MEMOBUS/Modbus Data Table in Appendix C of the drive Technical Manual for a list of monitor data using the MEMOBUS/Modbus message area.

◆ Speed/Torque Status Input (Vendor Specific Yaskawa Electric (YE) Assy) - 151 (0x97)

Output Instance	Word	Byte	Bit 7	Bit 6	Bit 5	Bit 4	Bit 3	Bit 2	Bit 1	Bit 0
151	0	0	Faulted	Alarm	Ready	Speed Agree	Reset	REV Running	ZSP	Running
		1	ZSV	-	Multi-Function Digital Output 3	Multi-Function Digital Output 2	Multi-Function Digital Output 1	LOCAL/REMOTE	UV	OPE
	1	2	Output Frequency (Low Byte)							
		3	Output Frequency (High Byte)							
	2	4	Torque Actual (Low Byte)							
		5	Torque Actual (High Byte)							
	3	6	Current Actual (Low Byte)							
		7	Current Actual (High Byte)							

Parameter	Data
Running	Running 0: Stop 1: Forward or Reverse Running
ZSP	Zero Speed 0: Running 1: Stop or DC Injection Braking
REV Running	Reverse Running 0: Not Reverse Running 1: Reverse Running
Reset	Reset 0: No Reset 1: Reset
Speed Agree	Speed Agree 0: No Speed Agree 1: Speed Actual at speed reference
Ready	Drive Ready 0: Not Ready 1: Ready
Alarm	Drive Alarm 0: No Drive Alarm 1: Alarm
Faulted	Drive Fault 0: No Drive Fault 1: Fault
OPE	OPE Fault 0: No oPE□□ Fault 1: oPE□□
UV	Under Voltage 0: No Under Voltage 1: Under Voltage
Local/Remote	Status of Run command from Network 0: Run command is not from network 1: Run command is from network

9 Input Assemblies (Drive Produces)

Parameter	Data
Multi-Function Digital Output 1	<p>1000-Series Drives, GA700, and GA800: Terminal M1/M2 (varies by drive model) 0: M1/M2 OFF 1: M1/M2 ON This function is enabled only when H2-01 is set to F. Note: The names of the digital outputs are different for different drive series. GA500: Terminal MA/MB 0: MA/MB OFF 1: MA/MB ON This function is enabled only when H2-01 is set to F.</p>
Multi-Function Digital Output 2	<p>1000-Series Drives, GA700, and GA800: Terminal M3/M4 (varies by drive model) 0: M3/M4 OFF 1: M3/M4 ON This function is enabled only when H2-02 is set to F. Note: The names of the digital outputs are different for different drive series. GA500: Terminal P1 0: P1 OFF 1: P1 ON This function is enabled only when H2-02 is set to F.</p>
Multi-Function Digital Output 3	<p>1000-Series Drives, GA700, and GA800: Terminal M5/M6 (varies by drive model) 0: M5/M6 OFF 1: M5/M6 ON This function is enabled only when H2-03 is set to F. Note: The names of the digital outputs are different for different drive series. GA500: Terminal P2 0: P2 OFF 1: P2 ON This function is enabled only when H2-03 is set to F.</p>
ZSV	<p>Zero Servo Completed 0: – 1: Completed</p>
Output Frequency	<p>Actual Drive Speed Monitors drive output frequency. Unit depends on o1-03. Unit is not affected by Speed Scale SS.</p>
Torque Actual	<p>Output Torque Shows the Torque Reference. Value displays in 0.1% units.</p>
Current Actual	<p>Actual Output Current Monitors drive output current. Unit is 0.01 A. Unit is not affected by Current Scale CS.</p>

◆ Extended Speed/Torque Status Input (Vendor Specific Yaskawa Electric (YE) Assy) - 155 (0x9B)

Input Instance	Word	Byte	Bit 7	Bit 6	Bit 5	Bit 4	Bit 3	Bit 2	Bit 1	Bit 0	
155	0	0	Faulted	Alarm	Ready	Speed Agree	Fault Reset	REV Running	Zero Speed	Running	
		1	ZSV	-	Multi-Function Digital Output 3	Multi-Function Digital Output 2	Multi-Function Digital Output 1	LOCAL/REMOTE	Uv	oPE	
	1	2	Motor Speed (Low Byte)								
		3	Motor Speed (High Byte)								
	2	4	Torque Actual (Low Byte)								
		5	Torque Actual (High Byte)								
	3	6	PG Count Value (Low Byte)								
		7	PG Count Value (High Byte)								
	4	8	Frequency Command (Low Byte)								
		9	Frequency Command (High Byte)								
	5	10	Output Frequency (Low Byte)								
		11	Output Frequency (High Byte)								
	6	12	Output Current (Low Byte)								
		13	Output Current (High Byte)								
	7	14	Terminal A2 Input (Low Byte)								
		15	Terminal A2 Input (High Byte)								
	8	16	Main Circuit DC Voltage (Low Byte)								
		17	Main Circuit DC Voltage (High Byte)								
	9	18	Error Alarm Signal 1 (Low Byte)								
		19	Error Alarm Signal 1 (High Byte)								
	10	20	Error Alarm Signal 2 (Low Byte)								
		21	Error Alarm Signal 2 (High Byte)								
	11	22	Error Alarm Signal 3 (Low Byte)								
		23	Error Alarm Signal 3 (High Byte)								
	12	24	Terminal A3 Input (Low Byte) <1>								
		25	Terminal A3 Input (High Byte) <1>								
	13	26	Terminal S1 to S8 Input (Low Byte) <2>								
		27	Terminal S1 to S8 Input (High Byte) <2>								
	14	28	Terminal A1 Input (Low Byte)								
		29	Terminal A1 Input (High Byte)								
	15	30	PG Counter (Ch2) (Low Byte)								
		31	PG Counter (Ch2) (High Byte)								
16 - 19	32 - 39	Not Used									

<1> GA500 does not have Terminal A3 Input.

<2> GA500 does not have Terminal S8.

9 Input Assemblies (Drive Produces)

Parameter	Data
Running	Running 0: Stop 1: Forward or Reverse Running
Zero Speed	Zero Speed 0: Running 1: Stop or DC Injection Braking
REV Running	Reverse Running 0: Not Reverse Running 1: Reverse Running
Fault Reset	Fault Reset command from Network 0: Fault Reset command is not from network 1: Fault Reset command is from network
Speed Agree	Speed Agree 0: No Speed Agree 1: Speed actual at speed reference
Ready	Drive Ready 0: Not Ready 1: Ready
Alarm	Drive Alarm 0: No Drive Alarm 1: Alarm
Faulted	Drive Fault 0: No Drive Fault 1: Fault
OPE	OPE Fault 0: No oPE□□ fault 1: oPE□□
Uv	Under Voltage 0: No Under Voltage 1: Under Voltage
Local/Remote	Status of Run command from Network 0: Run command is not from Network 1: Run Command is from Network
Multi-Function Digital Output 1	1000-Series Drives, GA700, and GA800: Terminal M1/M2 (varies by drive model) 0: M1/M2 OFF 1: M1/M2 ON This function is enabled only when H2-01 is set to F. Note: The names of the digital outputs are different for different drive series. GA500: Terminal MA/MB 0: MA/MB OFF 1: MA/MB ON This function is enabled only when H2-01 is set to F.
Multi-Function Digital Output 2	1000-Series Drives, GA700, and GA800: Terminal M3/M4 (varies by drive model) 0: M3/M4 OFF 1: M3/M4 ON This function is enabled only when H2-02 is set to F. Note: The names of the digital outputs are different for different drive series. GA500: Terminal P1 0: P1 OFF 1: P1 ON This function is enabled only when H2-02 is set to F.

Parameter	Data
Multi-Function Digital Output 3	1000-Series Drives, GA700, and GA800: Terminal M5/M6 (varies by drive model) 0: M5/M6 OFF 1: M5/M6 ON This function is enabled only when H2-03 is set to F. Note: The names of the digital outputs are different for different drive series. GA500: Terminal P2 0: P2 OFF 1: P2 ON This function is enabled only when H2-03 is set to F.
ZSV	Zero Servo Completed 0: – 1: Completed
Motor Speed	Monitor parameter U1-05
Torque Actual	Output Torque Shows the Torque Reference. Value displays in 0.1% units.
PG Count Value	MEMOBUS/Modbus (0x7CD) PG1 Count value register U6-18
Frequency Command	Monitor parameter U1-01
Output Frequency	Actual Drive Speed Monitors drive output frequency. Unit depends on o1-03. Unit is not affected by Speed Scale SS.
Output Current	Actual Output Current Monitors drive output current. Unit is 0.01 A Unit is not affected by Current Scale CS.
Terminal A2 Input	Analog Input 2 MEMOBUS/Modbus (0x4F) Monitor parameter U1-14
Main Circuit DC Voltage	Main Circuit DC Voltage Monitor parameter U1-07
Error Alarm Signal 1	Error Alarm Signal 1 MEMOBUS/Modbus (0xC8)
Error Alarm Signal 2	Error Alarm Signal 2 MEMOBUS/Modbus (0xC9)
Error Alarm Signal 3	Error Alarm Signal 3 MEMOBUS/Modbus (0xCA)
Terminal A3 Input <1>	Analog Input 3 MEMOBUS/Modbus (0x50) Monitor parameter U1-15
Terminal S1 to S8 <2>	MEMOBUS/Modbus (0x49) Monitor parameter U1-10
Terminal A1 Input	Analog Input 1 MEMOBUS/Modbus (0x46) Monitor parameter U1-13
PG Count Value (CH 2)	MEMOBUS/Modbus (0x7E5) PG Pulse Count for Channel 2 U6-19

<1> GA500 does not have Terminal A3 Input.

<2> GA500 does not have Terminal S8.

◆ High Speed/Torque Status Input (Vendor Specific Yaskawa Electric (YE) Assy) - 166 (0xA6)

If an error occurs while trying to read from the dynamic parameters, the appropriate error bit in Assembly 166 will be set. If more information about the nature of the error is needed, the extended error status can be read explicitly through Class 4, Instance 0xA6, Attribute 0x64. This will return 20 Bytes with each dynamic parameter in Assembly 166 having a Byte dedicated to its extended error status.

Input Instance	Word	Byte	Bit 7	Bit 6	Bit 5	Bit 4	Bit 3	Bit 2	Bit 1	Bit 0	
166	0	0	Faulted	Alarm	Ready	Speed Agree	Fault Reset	REV Running	Zero Speed	Running	
		1	ZSV	-	Multi-Function Digital Output 3	Multi-Function Digital Output 2	Multi-Function Digital Output 1	LOCAL/REMOTE	Uv	oPE	
	1	2	Motor Speed (Low Byte)								
		3	Motor Speed (High Byte)								
	2	4	Torque Actual (Low Byte)								
		5	Torque Actual (High Byte)								
	3	6	PG Count Value (Low Byte)								
		7	PG Count Value (High Byte)								
	4	8	Frequency Command (Low Byte)								
		9	Frequency Command (High Byte)								
	5	10	Output Frequency (Low Byte)								
		11	Output Frequency (High Byte)								
	6	12	Output Current (Low Byte)								
		13	Output Current (High Byte)								
	7	14	Terminal A1 Input (Low Byte)								
		15	Terminal A1 Input (High Byte)								
	8	16	Main Circuit DC Voltage (Low Byte)								
		17	Main Circuit DC Voltage (High Byte)								
	9	18	Error Code (Low Byte)								
		19	Error Code (High Byte)								
	10 <I>	20 <I>	Parameter F7-33 Default: Alarm Code (Low Byte)								
		21 <I>	Parameter F7-33 Default: Alarm Code (High Byte)								
	11 <I>	22 <I>	Parameter F7-34 Default: Output Power (Low Byte)								
		23 <I>	Parameter F7-34 Default: Output Power (High Byte)								
	12 <I>	24 <I>	Parameter F7-35 Default: Terminal A2 Input (Low Byte)								
		25 <I>	Parameter F7-35 Default: Terminal A2 Input (High Byte)								
	13 <I>	26 <I>	Parameter F7-36 Default: Terminal S1 to S8 Input (Low Byte) <2>								
		27 <I>	Parameter F7-36 Default: Terminal S1 to S8 Input (High Byte) <2>								
	14 <I>	28 <I>	Parameter F7-37 Default: Terminal A3 Input (Low Byte) <3>								
		29 <I>	Parameter F7-37 Default: Terminal A3 Input (High Byte) <3>								
	15 <I>	30 <I>	Parameter F7-38 Default: PG Counter (Ch2) (Low Byte)								
		31 <I>	Parameter F7-38 Default: PG Counter (CH2) (High Byte)								

Input Instance	Word	Byte	Bit 7	Bit 6	Bit 5	Bit 4	Bit 3	Bit 2	Bit 1	Bit 0	
166	16 <1>	32 <2>	Parameter F7-39 Default: NetRef and NetCtrl (Low Byte)								
			-	-	-	-	-	-	-	NetCtrl	NetRef
	17 <2>	33 <2>	Parameter F7-39 Default: NetRef and NetCtrl								
		34 <2>	Parameter F7-40 Default: Drive Software Version (Low Byte)								
	18 <2>	35 <2>	Parameter F7-40 Default: Drive Software Version (High Byte)								
		36 <2>	Parameter F7-41 (Low Byte) Default: Not Used								
	19 <2>	37 <2>	Parameter F7-41 (High Byte) Default: Not Used								
		38 <2>	Parameter F7-42 (Low Byte) Default: Not Used								
	20	39 <2>	Parameter F7-42 (High Byte) Default: Not Used								
		40	-	-	-	-	-	-	-	Assy. 116 F7-32 Error	Assy. 116 F7-31 Error
	21	41	Assy. 116 F7-30 Error	Assy. 116 F7-29 Error	Assy. 116 F7-28 Error	Assy. 116 F7-27 Error	Assy. 116 F7-26 Error	Assy. 116 F7-25 Error	Assy. 116 F7-24 Error	Assy. 116 F7-23 Error	Assy. 116 F7-22 Error
		42	-	-	-	-	-	-	-	Assy. 166 F7-42 Error	Assy. 166 F7-41 Error
	21	43	Assy. 166 F7-40 Error	Assy. 166 F7-39 Error	Assy. 166 F7-38 Error	Assy. 166 F7-37 Error	Assy. 166 F7-36 Error	Assy. 166 F7-35 Error	Assy. 166 F7-34 Error	Assy. 166 F7-33 Error	Assy. 166 F7-32 Error

- <1> Selectable with F7-33 to F7-42.
- <2> GA500 does not have Terminal S8.
- <3> GA500 does not have Terminal A3 Input.

Parameter	Data
Running	Running 0: Stop 1: Forward or Reverse Running
Zero Speed	Zero Speed 0: Running 1: Stop or DC Injection Braking
REV Running	Reverse Running 0: Not Reverse Running 1: Reverse Running
Fault Reset	Fault Reset command from Network 0: Fault Reset command is not from network 1: Fault Reset command is from network
Speed Agree	Speed Agree 0: No Speed Agree 1: Speed actual at speed reference
Ready	Drive Ready 0: Not Ready 1: Ready
Alarm	Drive Alarm 0: No Drive Alarm 1: Alarm
Faulted	Drive Fault 0: No Drive Fault 1: Fault
OPE	OPE Fault 0: No oPE□□ fault 1: oPE□□
Uv	Under Voltage 0: No Under Voltage 1: Under Voltage

9 Input Assemblies (Drive Produces)

Parameter	Data
Local/Remote	Status of Run command from Network 0: Run command is not from Network 1: Run Command is from Network
Multi-Function Digital Output 1	1000-Series Drives, GA700, and GA800: Terminal M1/M2 (varies by drive model) 0: M1/M2 OFF 1: M1/M2 ON This function is enabled only when H2-01 is set to F. Note: The names of the digital outputs are different for different drive series. GA500: Terminal MA/MB 0: MA/MB OFF 1: MA/MB ON This function is enabled only when H2-01 is set to F.
Multi-Function Digital Output 2	1000-Series Drives, GA700, and GA800: Terminal M3/M4 (varies by drive model) 0: M3/M4 OFF 1: M3/M4 ON This function is enabled only when H2-02 is set to F. Note: The names of the digital outputs are different for different drive series. GA500: Terminal P1 0: P1 OFF 1: P1 ON This function is enabled only when H2-02 is set to F.
Multi-Function Digital Output 3	1000-Series Drives, GA700, and GA800: Terminal M5/M6 (varies by drive model) 0: M5/M6 OFF 1: M5/M6 ON This function is enabled only when H2-03 is set to F. Note: The names of the digital outputs are different for different drive series. GA500: Terminal P2 0: P2 OFF 1: P2 ON This function is enabled only when H2-03 is set to F.
ZSV	Zero Servo Completed 0: – 1: Completed
Motor Speed	Monitor parameter U1-05
Torque Actual	Output Torque Shows the Torque Reference. Value displays in 0.1% units.
PG Count Value	Contained MEMOBUS/Modbus Address PG1 Count value register (0xF0)
Frequency Command	Monitor parameter U1-01
Output Frequency	Actual Drive Speed Monitors drive output frequency. Unit depends on o1-03. Unit is not affected by Speed Scale SS.
Output Current	Actual Output Current Monitors drive output current. Unit is 0.01 A Unit is not affected by Current Scale CS.
Drive Terminal A1 Input	MEMOBUS/Modbus (0x46) Monitor parameter U1-13
Main DC Voltage	Main Circuit DC Voltage Monitor parameter U1-07
Error Code	U2-01 converted using fault code table
F7-33 Alarm Code	Programmable: MEMOBUS/Modbus (0x7F)
F7-34 Output Power	Programmable: MEMOBUS/Modbus (0x47) Monitor parameter U1-08

Parameter	Data
F7-35 Terminal A2 Input	Programmable: MEMOBUS/Modbus (0x4F) Monitor parameter U1-14
F7-36 Drive Terminal S1 to S8 <1>	Programmable: MEMOBUS/Modbus (0x49) Monitor parameter U1-10
F7-37 Terminal A3 Input <2>	Programmable: MEMOBUS/Modbus (0x50)
F7-38 PG Count Value (CH 2)	Programmable: MEMOBUS/Modbus (0x7E5) PG Pulse Count for Channel 2 U6-19
F7-39 NetRef (Status)	Status of reference command from Network 0: Reference command is not from network 1: Reference command is from network
F7-40 Drive Software Version	Programmable: MEMOBUS/Modbus (0x4D) Monitor parameter U1-25

<1> GA500 does not have Terminal S8.

<2> GA500 does not have Terminal A3 Input.

Possible extended error codes are listed in [Table 13](#) and [Table 14](#). If an error occurs, extended error code 0x02 (Register number failure) is usually set.

Table 13 Extended Error Codes for Assembly 116/166

Error Code	Description
0x00	No Error
0x01	Sub function code failure
0x02	Register number failure
0x21	Limit check error failure
0x22	Write failure
0x23	Write failure at Uv
0x24	Write failure at busy

Table 14 Extended Error Codes in Class 0x04 Instance 0xA6 Attribute 0x64

Dynamic Parameter	Byte Containing Extended Error Code
F7-23	Byte 0
F7-24	Byte 1
F7-25	Byte 2
F7-26	Byte 3
F7-27	Byte 4
F7-28	Byte 5
F7-29	Byte 6
F7-30	Byte 7
F7-31	Byte 8
F7-32	Byte 9
F7-33	Byte 10
F7-34	Byte 11
F7-35	Byte 12
F7-36	Byte 13
F7-37	Byte 14
F7-38	Byte 15
F7-39	Byte 16
F7-40	Byte 17
F7-41	Byte 18
F7-42	Byte 19

◆ 8-Byte Dynamic Input 167 (0xA7)

Input Instance	Word	Byte	Bit 7	Bit 6	Bit 5	Bit 4	Bit 3	Bit 2	Bit 1	Bit 0	
167	0	0	Faulted	Alarm	Ready	Speed Agree	Fault Reset	Reverse Running	Zero Speed	Running	
		1	ZSV	–	Multi-Function Digital Output 3	Multi-Function Digital Output 2	Multi-Function Digital Output 1	LOCAL/REMOTE	Uv	oPE	
	1	2	Output Frequency (Low Byte)								
		3	Output Frequency (High Byte)								
	2	4-5	Dynamic Input 1 (F7-33) Default: Alarm Code								
	3	6-7	Dynamic Input 2 (F7-34) Default: Output Power (U1-08)								

Name	Description
Running	Running 0: Stop 1: Forward or Reverse Running
Zero Speed	Zero Speed 0: Running 1: Stop or DC Injection Braking
REV Running	Reverse Running 0: Not Reverse Running 1: Reverse Running
Fault Reset	Fault Reset command from Network 0: Fault Reset command is not from network 1: Fault Reset command is from network
Speed Agree	Speed Agree 0: No Speed Agree 1: Speed Actual at speed reference
Ready	Drive Ready 0: Not Ready 1: Ready
Alarm	Drive Alarm 0: No Drive Alarm 1: Alarm
Faulted	Drive Fault 0: No Drive Fault 1: Fault
oPE	oPE Fault 0: No oPE Fault 1: oPE
Uv	Undervoltage 0: No Undervoltage 1: Undervoltage
LOCAL/REMOTE	Status of Run command from Network 0: Run command is not from network 1: Run command is from network
Multi-Function Digital Output 1	1000-Series Drives, GA700, and GA800: Terminal M1/M2 (varies by drive model) 0: M1/M2 OFF 1: M1/M2 ON This function is enabled only when H2-01 is set to F. Note: The names of the digital outputs are different for different drive series. GA500: Terminal MA/MB 0: MA/MB OFF 1: MA/MB ON This function is enabled only when H2-01 is set to F.

Name	Description
Multi-Function Digital Output 2	1000-Series Drives, GA700, and GA800: Terminal M3/M4 (varies by drive model) 0: M3/M4 OFF 1: M3/M4 ON This function is enabled only when H2-02 is set to F. Note: The names of the digital outputs are different for different drive series. GA500: Terminal P1 0: P1 OFF 1: P1 ON This function is enabled only when H2-02 is set to F.
Multi-Function Digital Output 3	1000-Series Drives, GA700, and GA800: Terminal M5/M6 (varies by drive model) 0: M5/M6 OFF 1: M5/M6 ON This function is enabled only when H2-03 is set to F. Note: The names of the digital outputs are different for different drive series. GA500: Terminal P2 0: P2 OFF 1: P2 ON This function is enabled only when H2-03 is set to F.
Output Frequency	Actual Drive Speed Monitors drive output frequency. Unit depends on o1-03. Unit is not affected by Speed Scale SS.
Dynamic Inputs	Contains the data to be read from the MEMOBUS/Modbus address defined in the given parameter. A value of 0 in the given parameter means it will return the default data as defined in the table above.

◆ 12-Byte Dynamic Input 168 (0xA8)

Input Instance	Word	Byte	Bit 7	Bit 6	Bit 5	Bit 4	Bit 3	Bit 2	Bit 1	Bit 0	
168	0	0	Faulted	Alarm	Ready	Speed Agree	Fault Reset	Reverse Running	Zero Speed	Running	
		1	ZSV	–	Multi-Function Digital Output 3	Multi-Function Digital Output 2	Multi-Function Digital Output 1	LOCAL/REMOTE	Uv	oPE	
	1	2	Output Frequency (Low Byte)								
		3	Output Frequency (High Byte)								
	2	4-5	Dynamic Input 1 (F7-33) Default: Alarm Code								
	3	6-7	Dynamic Input 2 (F7-34) Default: Output Power (U1-08)								
	4	8-9	Dynamic Input 3 (F7-35) Default: Analog Input 2								
5	10-11	Dynamic Input 4 (F7-36) Default: Digital Input									

Name	Description
Running	Running 0: Stop 1: Forward or Reverse Running
Zero Speed	Zero Speed 0: Running 1: Stop or DC Injection Braking
REV Running	Reverse Running 0: Not Reverse Running 1: Reverse Running
Fault Reset	Fault Reset command from Network 0: Fault Reset command is not from network 1: Fault Reset command is from network

9 Input Assemblies (Drive Produces)

Name	Description
Speed Agree	Speed Agree 0: No Speed Agree 1: Speed Actual at speed reference
Ready	Drive Ready 0: Not Ready 1: Ready
Alarm	Drive Alarm 0: No Drive Alarm 1: Alarm
Faulted	Drive Fault 0: No Drive Fault 1: Fault
oPE	oPE Fault 0: No oPE Fault 1: oPE
Uv	Undervoltage 0: No Undervoltage 1: Undervoltage
LOCAL/REMOTE	Status of Run command from Network 0: Run command is not from network 1: Run command is from network
Multi-Function Digital Output 1	1000-Series Drives, GA700, and GA800: Terminal M1/M2 (varies by drive model) 0: M1/M2 OFF 1: M1/M2 ON This function is enabled only when H2-01 is set to F. Note: The names of the digital outputs are different for different drive series. GA500: Terminal MA/MB 0: MA/MB OFF 1: MA/MB ON This function is enabled only when H2-01 is set to F.
Multi-Function Digital Output 2	1000-Series Drives, GA700, and GA800: Terminal M3/M4 (varies by drive model) 0: M3/M4 OFF 1: M3/M4 ON This function is enabled only when H2-02 is set to F. Note: The names of the digital outputs are different for different drive series. GA500: Terminal P1 0: P1 OFF 1: P1 ON This function is enabled only when H2-02 is set to F.
Multi-Function Digital Output 3	1000-Series Drives, GA700, and GA800: Terminal M5/M6 (varies by drive model) 0: M5/M6 OFF 1: M5/M6 ON This function is enabled only when H2-03 is set to F. Note: The names of the digital outputs are different for different drive series. GA500: Terminal P2 0: P2 OFF 1: P2 ON This function is enabled only when H2-03 is set to F.
Output Frequency	Actual Drive Speed Monitors drive output frequency. Unit depends on o1-03. Unit is not affected by Speed Scale SS.
Dynamic Inputs	Contains the data to be read from the MEMOBUS/Modbus address defined in the given parameter. A value of 0 in the given parameter means it will return the default data as defined in the table above.

◆ 18-Byte Dynamic Input 169 (0xA9)

Input Instance	Word	Byte	Bit 7	Bit 6	Bit 5	Bit 4	Bit 3	Bit 2	Bit 1	Bit 0	
169	0	0	Faulted	Alarm	Ready	Speed Agree	Fault Reset	Reverse Running	Zero Speed	Running	
		1	ZSV	–	Multi-Function Digital Output 3	Multi-Function Digital Output 2	Multi-Function Digital Output 1	LOCAL/REMOTE	Uv	oPE	
	1	2	Output Frequency (Low Byte)								
		3	Output Frequency (High Byte)								
	2	4-5	Dynamic Input 1 (F7-33) Default: Alarm Code								
	3	6-7	Dynamic Input 2 (F7-34) Default: Output Power (U1-08)								
	4	8-9	Dynamic Input 3 (F7-35) Default: Analog Input 2								
	5	10-11	Dynamic Input 4 (F7-36) Default: Digital Input								
	6	12-13	Dynamic Input 5 (F7-37) Default: Analog Input 3 <1>								
	7	14-15	Dynamic Input 6 (F7-38) Default: PG 2 Counter								
8	16-17	Dynamic Input 7 (F7-39) Default: Net Ref and Net Ctrl									

<1> GA500 does not have Analog Input 3.

Name	Description
Running	Running 0: Stop 1: Forward or Reverse Running
Zero Speed	Zero Speed 0: Running 1: Stop or DC Injection Braking
REV Running	Reverse Running 0: Not Reverse Running 1: Reverse Running
Fault Reset	Fault Reset command from Network 0: Fault Reset command is not from network 1: Fault Reset command is from network
Speed Agree	Speed Agree 0: No Speed Agree 1: Speed Actual at speed reference
Ready	Drive Ready 0: Not Ready 1: Ready
Alarm	Drive Alarm 0: No Drive Alarm 1: Alarm
Faulted	Drive Fault 0: No Drive Fault 1: Fault
oPE	oPE Fault 0: No oPE Fault 1: oPE
Uv	Undervoltage 0: No Undervoltage 1: Undervoltage
LOCAL/REMOTE	Status of Run command from Network 0: Run command is not from network 1: Run command is from network

9 Input Assemblies (Drive Produces)

Name	Description
Multi-Function Digital Output 1	1000-Series Drives, GA700, and GA800: Terminal M1/M2 (varies by drive model) 0: M1/M2 OFF 1: M1/M2 ON This function is enabled only when H2-01 is set to F. Note: The names of the digital outputs are different for different drive series. GA500: Terminal MA/MB 0: MA/MB OFF 1: MA/MB ON This function is enabled only when H2-01 is set to F.
Multi-Function Digital Output 2	1000-Series Drives, GA700, and GA800: Terminal M3/M4 (varies by drive model) 0: M3/M4 OFF 1: M3/M4 ON This function is enabled only when H2-02 is set to F. Note: The names of the digital outputs are different for different drive series. GA500: Terminal P1 0: P1 OFF 1: P1 ON This function is enabled only when H2-02 is set to F.
Multi-Function Digital Output 3	1000-Series Drives, GA700, and GA800: Terminal M5/M6 (varies by drive model) 0: M5/M6 OFF 1: M5/M6 ON This function is enabled only when H2-03 is set to F. Note: The names of the digital outputs are different for different drive series. GA500: Terminal P2 0: P2 OFF 1: P2 ON This function is enabled only when H2-03 is set to F.
Output Frequency	Actual Drive Speed Monitors drive output frequency. Unit depends on o1-03. Unit is not affected by Speed Scale SS.
Dynamic Inputs	Contains the data to be read from the MEMOBUS/Modbus address defined in the given parameter. A value of 0 in the given parameter means it will return the default data as defined in the table above.

◆ 24-Byte Dynamic Input 170 (0xAA)

Input Instance	Word	Byte	Bit 7	Bit 6	Bit 5	Bit 4	Bit 3	Bit 2	Bit 1	Bit 0	
170	0	0	Faulted	Alarm	Ready	Speed Agree	Fault Reset	Reverse Running	Zero Speed	Running	
		1	ZSV	–	Multi-Function Digital Output 3	Multi-Function Digital Output 2	Multi-Function Digital Output 1	LOCAL/REMOTE	Uv	oPE	
	1	2	Output Frequency (Low Byte)								
		3	Output Frequency (High Byte)								
	2	4-5	Dynamic Input 1 (F7-33) Default: Alarm Code								
	3	6-7	Dynamic Input 2 (F7-34) Default: Output Power (U1-08)								
	4	8-9	Dynamic Input 3 (F7-35) Default: Analog Input 2								
	5	10-11	Dynamic Input 4 (F7-36) Default: Digital Input								
	6	12-13	Dynamic Input 5 (F7-37) Default: Analog Input 3 <I>								
	7	14-15	Dynamic Input 6 (F7-38) Default: PG 2 Counter								
	8	16-17	Dynamic Input 7 (F7-39) Default: Net Ref and Net Ctrl								
	9	18-19	Dynamic Input 8 (F7-40) Default: Drive Software Version								
	10	20-21	Dynamic Input 9 (F7-41) Default: Not Used								
11	22-23	Dynamic Input 10 (F7-42) Default: Not Used									

<I> GA500 does not have Analog Input 3.

Name	Description
Running	Running 0: Stop 1: Forward or Reverse Running
Zero Speed	Zero Speed 0: Running 1: Stop or DC Injection Braking
REV Running	Reverse Running 0: Not Reverse Running 1: Reverse Running
Fault Reset	Fault Reset command from Network 0: Fault Reset command is not from network 1: Fault Reset command is from network
Speed Agree	Speed Agree 0: No Speed Agree 1: Speed Actual at speed reference
Ready	Drive Ready 0: Not Ready 1: Ready
Alarm	Drive Alarm 0: No Drive Alarm 1: Alarm
Faulted	Drive Fault 0: No Drive Fault 1: Fault
oPE	oPE Fault 0: No oPE Fault 1: oPE
Uv	Undervoltage 0: No Undervoltage 1: Undervoltage
LOCAL/REMOTE	Status of Run command from Network 0: Run command is not from network 1: Run command is from network

9 Input Assemblies (Drive Produces)

Name	Description
Multi-Function Digital Output 1	1000-Series Drives, GA700, and GA800: Terminal M1/M2 (varies by drive model) 0: M1/M2 OFF 1: M1/M2 ON This function is enabled only when H2-01 is set to F. Note: The names of the digital outputs are different for different drive series. GA500: Terminal MA/MB 0: MA/MB OFF 1: MA/MB ON This function is enabled only when H2-01 is set to F.
Multi-Function Digital Output 2	1000-Series Drives, GA700, and GA800: Terminal M3/M4 (varies by drive model) 0: M3/M4 OFF 1: M3/M4 ON This function is enabled only when H2-02 is set to F. Note: The names of the digital outputs are different for different drive series. GA500: Terminal P1 0: P1 OFF 1: P1 ON This function is enabled only when H2-02 is set to F.
Multi-Function Digital Output 3	1000-Series Drives, GA700, and GA800: Terminal M5/M6 (varies by drive model) 0: M5/M6 OFF 1: M5/M6 ON This function is enabled only when H2-03 is set to F. Note: The names of the digital outputs are different for different drive series. GA500: Terminal P2 0: P2 OFF 1: P2 ON This function is enabled only when H2-03 is set to F.
Output Frequency	Actual Drive Speed Monitors drive output frequency. Unit depends on o1-03. Unit is not affected by Speed Scale SS.
Dynamic Inputs	Contains the data to be read from the MEMOBUS/Modbus address defined in the given parameter. A value of 0 in the given parameter means it will return the default data as defined in the table above.

10 General Class Objects

◆ Identity Object 1 (Class 0x01)

■ Services Supported

Service Code No. (hex)	Service Name
01	Get Attribute All
05	Reset
0E	Get Attribute Single

■ Attributes Supported

Instance ID	Attribute	Name	Description	Get	Set	Size	Range	Default
0	1	Object Software Revision	Identity Object software revision	O	–	Word	–	1
1	1	Vendor ID	Manufacturer code. 44 (2C H): Yaskawa Electric	O	–	Word	–	44 (Yaskawa)
1	2	Device Type	Device profile. The profile for this product is an AC drive. 2: AC drive	O	–	Word	–	2 (AC drives)
1	3	Product Code	Product codes determined by the manufacturer.	O	–	Word	–	<I>
1	4	Revision	Software revision for the option.	O	–	Word	–	Depends on software
1	5	Status	Shows the communication status for the drive.	O	–	Word	–	0
1	6	Serial Number	Option serial number.	O	–	Long	–	Each unit is unique
1	7	Product Name	Product Name	O	–	String	–	Product dependent (i.e., CIMR-□)
1	8	State	Operation status of the drive. 3: Drive ready 4: Fault	O	–	Byte	–	3 State of the Drive

<I> Product code is 2 Bytes. The first Byte is the drive type and the second Byte is the model number of the drive.

◆ Assembly Object 4 (Class 0x04)

■ Services Supported

Service Code No. (hex)	Service Name
0E	Get Attribute Single
10	Set Attribute Single

■ Attributes Supported

Instance ID	Attribute	Name	Description	Get	Set	Size	Range	Default
0	1	Object Software Revision	Show the EtherNet Object software revision.	O	–	Word	–	2
20	3	Data	Same function as the Basic Speed Control (Output Assembly)	O	O	Array 4 Bytes	–	00 00 00 00
21	3	Data	Same function as the Extended Speed Control (Output Assembly)	O	O	Array 4 Bytes	–	00 00 00 00
22	3	Data	Same function as the Speed and Torque Control (Output Assembly)	O	O	Array 6 Bytes	–	00 00 00 00 00 00
23	3	Data	Same function as the Extended Speed and Torque Control (Output Assembly)	O	O	Array 6 Bytes	–	00 00 00 00 00 00

■ Attributes Supported

Instance ID	Attribute	Name	Description	Get	Set	Size	Range	Default
0	1	Object Software Revision	Motor Data Object software revision.	O	–	Word	–	1
1	3	Motor Type	Different for different control methods. When set for Open Loop Vector for PM motors (A1-02 = 5), value becomes 3 (PM motor). When the drive is set for V/f Control (A1-02 = 0) or Open Loop Vector (A1-02 = 2), value becomes 7 (squirrel cage motor). Note: On GA700, GA800, when A1-02 = 8 (EZ vector control), this looks at E9-01 (E9-01 = 0 value becomes 7, E9-01 = 1 value becomes 3).	O	–	Byte	–	Depends on A1-02, Control Method Selection
1	6	Rated Current [0.1 A]	Motor rated current (E2-01). Displayed in 0.1 A units. Changes according to the current scale (CS).	O	O	Byte	–	Depends on capacity
1	7	Rated Voltage [1V]	Motor rated voltage (E1-01). Displayed in 1 V units. Changes according to the voltage scale (VS).	O	O	Byte	–	Depends on capacity

◆ Control Supervisor Object 41 (Class 0x29)

■ Services Supported

Service Code No. (hex)	Service Name
0E	Get Attribute Single
10	Set Attribute Single
05	Reset

■ Attributes Supported

Instance ID	Attribute	Name	Description	Get	Set	Size	Range	Default
0	1	Object Software Revision	Revision number of the Control Supervisor Object.	O	–	Word	–	1
1	3	Run 1 (Forward Run Command)	Forward Running 0: Stop 1: Forward Running	O	O	Byte	0, 1	0
1	4	Run 2 (Reverse Run Command)	Reverse Running 0: Stop 1: Reverse Running	O	O	Byte	0, 1	0
1	5	NetCtrl (Command)	Run command from Network 0: Depends on b1-02 1: Enables the run command from network	O	O	Byte	0, 1	0
1	6	State	Drive Status. 2: Not Ready 3: Ready (Stopped) 4: Enabled (Run command present) 5: Deceleration to Stop 6: Fault Stop 7: Fault	O	–	Byte	–	3
1	7	Running 1 (FWD)	Forward Running 0: Stop 1: Forward Running	O	–	Byte	–	0
1	8	Running 1 (REV)	Reverse Running 0: Stop 1: Reverse Running	O	–	Byte	–	0
1	9	Ready	Drive Ready 0: Not Ready 1: Ready	O	–	Byte	–	1

10 General Class Objects

Instance ID	Attribute	Name	Description	Get	Set	Size	Range	Default
1	10	Faulted	Drive Fault 0: No Drive Fault 1: Fault	O	-	Byte	-	0
1	11	Warning	Warning 0: No Warning 1: Warning	O	-	Byte	-	0
1	12	Fault Reset	Fault Reset 0: No Fault Reset 1: Fault Reset	O	O	Byte	0, 1	0
1	13	Fault Code	Current Fault Refer to Option Fault Code Conversion Table for details	O	-	Word	-	0000
1	15	Control from Net (Status)	Run Command from the option 0: The run command is not from the option 1: Enables the run command from option	O	-	Byte	-	0
1	16	NetFaultMode	Normal 2 (Vendor Specific)	O	-	Byte	-	2
1	17	Force Fault	External Fault 0: No External Fault 1: External Fault (EF0) Triggered by the rising edge of the signal.	O	O	Byte	0, 1	0
1	18	ForceStatus	External Fault status 0: No External Fault 1: External Fault (EF0) Triggered by the rising edge of the signal.	O	-	Byte	-	0

■ Option Fault Code Conversion Table

Drive Fault Code (Hex) (MEMOBUS/Modbus 0080 Hex)	Option Fault Code (hex)	Description
0	0000	None
2	3220	DC Bus Undervolt (Uv1)
3	5110	CTL PS Undervolt (Uv2)
4	3222	MC Answerback (Uv3)
6	2120	Ground Fault (GF)
7	2300	Over Current (oC)
8	3210	DC Bus Overvoltage (ov)
9	4200	Heatsink Overtemp (oH)
10	4210	Heatsink Max Temp (oH1)
11	2220	Motor Overload (oL1)
12	2200	Drive Overload (oL2)
13	2221	Overtorque Det 1 (oL3)
14	2222	Overtorque Det 2 (oL4)
15	7110	DynBrk Transistor (rr)
16	7112	DynBrk Resistor (rH)
17	9000	External Fault 3 (EF3)
18	9000	External Fault 4 (EF4)
19	9000	External Fault 5 (EF5)
20	9000	External Fault 6 (EF6)
21	9000	External Fault 7 (EF7)
22	9000	External Fault 8 (EF8)
24	7310	Overspeed Det (oS)
25	7310	Speed Deviation (dEv)
26	7301	PG Open (PGo)
27	3130	Input Phase Loss (PF)
28	3130	Output Phase Loss (LF)
29	5210	Motor Overheat 1 (PTC Input) (oH3)
30	5300	Keypad Disconnected (oPr)
31	6320	EEPROM R/W Error (Err)
32	3210	Motor OverHeat 2 (PTC Input) (oH4)

Drive Fault Code (Hex) (MEMOBUS/Modbus 0080 Hex)	Option Fault Code (hex)	Description
33	7500	MEMBOUS/Modbus Com Fault (CE)
34	7500	EtherNet/IP Communication Error (bUS)
37	8321	Out of Control (CF)
39	9000	External Fault 0 (EF0)
40	8000	PID Feedback Loss (FbL)
41	8000	Undertorque Detection 1 (UL3)
42	8000	Undertorque Detection 2 (UL4)
43	8000	High Slip Braking oL (oL7)
50	8000	Z Pulse Fault Detection (dv1)
51	8000	Z Pulse Noise Fault Detection (dv2)
52	8000	Inversion Detection (dv3)
53	8000	Inversion Prevention Detection (dv4)
54	8000	Current Imbalance (LF2)
55	8000	Pull-Out Detection (STo) Note: When using YASKAWA AC Drive GA500, GA700, or GA800, "STPo" (Motor Pull Out or Step Out Detection) will be shown.
56	7000	PG Hardware Fault (PGoH)
59	1000	Too Many Speed Search Restarts (SEr)
65	8000	Excessive PID Feedback (FbH)
66	9000	External Fault (input terminal S1) (EF1)
67	9000	External Fault (input terminal S2) (EF2)
68	8000	Mechanical Weakening Detection 1 (oL5)
69	8000	Mechanical Weakening Detection 2 (UL5)
70	5000	Current Offset Fault (CoF)
73	8000	DriveWorksEZ Fault (dwFL)
77	5000	Output Voltage Detection Fault (voF)
78	7000	Braking Resistor Fault (rF)
79	7000	Braking Transistor Overload Fault (boL)
–	1000	Other faults

◆ AC/DC Drive Object 42 (Class 0x2A)

■ Services Supported

Service Code No. (hex)	Service Name
0E	Get Attribute Single
10	Set Attribute Single

■ Attributes Supported

Instance ID	Attribute	Name	Description	Get	Set	Size	Range	Default
0	1	Object Software Revision	Revision number of AC/DC drive object	O	–	Word	–	1
1	3	AtReference	Speed Agree 0: – 1: Speed Agree	O	–	Byte	–	0
1	4	NetRef (Command)	Status of reference command from EtherNet/IP 0: Reference command not from option 1: Reference command from the option	O	–	Byte	–	0

10 General Class Objects

Instance ID	Attribute	Name	Description	Get	Set	Size	Range	Default
1	6	Drive Mode	Drive control mode. 0: OLV, OLV for PM (Read only), Advanced OLV for PM (Read only) 1: V/f 2: V/f with PG 3: CLV, CLV for PM (Read only) Note: On GA500, GA700 and GA800, setting 1 also includes EZOLV (Read only).	O	O	Byte	0 to 3	0
1	7	Speed Actual	Actual drive speed.	O	-	Word	-	3
1	8	Speed Reference	Frequency Reference. Monitors the drive's frequency reference.	O	O	Word	-	0
1	9	Current Actual	Actual Output Current. Unit is 0.01 A for drives set up to 11 kW in Heavy Duty or Normal Duty and 0.1 A for drives set up for 15 kW and above.	O	-	Word	-	0
1	11	Torque Actual	Drive Output Torque Unit is affected by Torque Scale (TS)	O	-	Word	-	0
1	12	Torque References/ Torque Limit	Torque Reference/Torque Limit Sets the Torque Reference/Torque Limit. The units is affected by Torque Scale. Sets the Torque Reference when using Torque Control (d5-01 = 1). <1> Sets the Torque Limit when using Speed Control (d5-01 = 0) The Torque Reference/Torque Limit are disabled when F6-06 = 0.	O	O	Word	-	0
1	15	Power Actual (W)	Drive Output Power Unit is affected by Power Scale (PS).	O	-	Word	-	0
1	16	Input Voltage (V)	Drive Input Voltage (E1-01) Unit is affected by Voltage Scale (VS).	O	-	Word	-	Depends on Capacity
1	17	Output Voltage (V)	Drive Output Voltage Unit is affected by Voltage Scale (VS).	O	-	Word	-	0
1	18	Accel Time (ms)	Acceleration Time 1 (C1-01) Units set in parameter C1-10. Unit is affected by Time Scale (TS).	O	O	Word	-	2710H
1	19	Decel Time (ms)	Acceleration Time 1 (C1-02) Units set in parameter C1-10. Unit is affected by Time Scale (TS).	O	O	Word	-	2710H
1	20	Low Speed Limit Percent of Max Speed	Frequency Reference Lower Limit (d2-02)	O	O	Word	0 to 1100	0
1	21	High Speed Limit Percent of Max Speed	Frequency Reference Upper Limit (d2-01)	O	O	Word	0 to 1100	3E8H
1	22	Speed Scale (-15 to 15)	Setting for F7-17, scale of units for speed related data.	O	O	Byte	-15 to 15	0
1	23	Current Scale (-15 to 15)	Setting for F7-18, scale of units for current related data.	O	O	Byte	-15 to 15	0
1	24	Torque Scale (-15 to 15)	Setting for F7-19, scale of units for torque related data.	O	O	Byte	-15 to 15	0
1	26	Power Scale (-15 to 15)	Setting for F7-20, scale of units for power related data.	O	O	Byte	-15 to 15	0
1	27	Voltage Scale (-15 to 15)	Setting for F7-21, scale of units for voltage related data.	O	O	Byte	-15 to 15	0
1	28	Time Scale (-15 to 15)	Setting for F7-22, scale of units for speed related data	O	O	Byte	-15 to 15	0
1	29	Reference from Net (Status)	Status of Reference Command (1 = Network). 0: As set by the drive parameters (i.e., b1-01) 1: Network	O	-	Byte	-	0

<1> Torque Control is not available for GA500.

◆ Base Energy Object 78 (Class 0x4E)

■ Services Supported

Service Code No. (hex)	Service Name
0E	Get Attribute Single
10	Set Attribute Single

■ Attributes Supported

Instance ID	Attribute	Name	Description	Get	Set	Size	Range	Default
0	1	Object Software Revision	Base Energy Object software revision	0	–	Word	–	2
1	1	Energy/Resource Type	Type of energy managed	0	–	Word	–	Always 1 (Electrical)
1	2	Base Energy Object Capabilities	Energy Capabilities of this device	0	–	Word	–	Always 0 (Measured)
1	3	Energy Accuracy	Specifies the accuracy of power and energy metering results	0	–	Word	–	Always 1000 (10%)
1	7	Consumed Energy Odometer	The consumed energy value read from U4-10, U4-11 in units of kWh	0	–	ODOMET ER Array of 5 words	0 to 999,999,999,999.999	–
1	8	Generated Energy Odometer	Always returns 0	0	–	ODOMET ER Array of 5 words	0 to 999,999,999,999.999	–
1	9	Net Energy Odometer	The difference between Consumed energy and Generated energy in units of kWh	0	–	SIGNED ODOMET ER Array of 5 signed Words	-999,999,999,999.999 to 999,999,999,999.999	–
1	10	Energy Transfer Rate	Output Power read from monitor U1-08 in units of 1kW. In IEEE 754 REAL format.	0	–	REAL	Depends on drive capacity	–
1	12	Energy Type Specific Object Path	EPATH to Electrical Energy Object	0	–	STRUCT of UINT Size Padded EPATH	–	Always 02 20 4F 24 01

◆ Electrical Energy Object 79 (Class 0x4F)

■ Services Supported

Service Code No. (hex)	Service Name
0E	Get Attribute Single
10	Set Attribute Single

■ Attributes Supported

Instance ID	Attribute	Name	Description	Get	Set	Size	Range	Default
0	1	Object Software Revision	Base Energy Object software revision	0	–	Word	–	2
1	1	Consumed Energy Odometer	The consumed energy value read from U4-10, U4-11 in units of kWh	0	–	ODOMET ER Array of 5 words	0 to 999,999,999,999.999	–

10 General Class Objects

Instance ID	Attribute	Name	Description	Get	Set	Size	Range	Default
1	2	Generated Energy Odometer	Always returns 0	O	-	ODOMETER Array of 5 words	0 to 999,999,999,999.999	-
1	3	Net Energy Odometer	The difference between Consumed energy and Generated energy in units of kWh	O	-	SIGNED ODOMETER Array of 5 signed Words	-999,999,999,999.999 to 999,999,999,999.999	-
1	41	Energy Type Specific Object Path	EPATH to Electrical Energy Object	O	-	STRUCT of UINT Size Padded EPATH	-	Always 02 20 4E 24 01

◆ TCP/IP Object 245 (Class 0xF5)

■ Services Supported

Service Code No. (hex)	Service Name
01	Get Attribute All
0E	Get Attribute Single
10	Set Attribute Single

■ Attributes Supported

Instance ID	Attribute	Name	Description	Get	Set	Size	Range	Default
0	1	Object Software Revision	Revision number of the TCP/IP Object	O	-	Word	-	3
1	1	Status	Bits 0-3 = Interface Status 0: Interface has not been configured 1: Interface Configuration is valid, obtained from BOOTP, DHCP, or NVRAM 2: Interface Configuration is valid and obtained from hardware settings 3: Reserved Bit 4 = Multicast Pending Bits 5-31 = Reserved	O	-	DWord	-	-
1	2	Configuration Capability	Bit 0 = BOOTP Client Bit 1 = DNS Client Bit 2 = DHCP Client Bit 3 = DHCP-DNS Update Bit 4 = Configuration Settable Bits 5-31 = Reserved	O	-	DWord	-	-
1	3	Configuration Control	Bits 0-3 = Startup Configuration 0: NVRAM 1: BOOTP 2: DHCP 3: Reserved Bit 4 = DNS Enabled (not supported) Bits 5-31 = Reserved	O	O	DWord	-	-
1	4	Physical Link	Struct of: Path Size: Word Path: EPATH	O	-	Struct	-	02H 00H 20H F6H 24H 01H
1	5	Interface Configuration	Struct of: IP Address = Long Subnet Mask = Long Gateway Address = Long Name Server1 = Long Name Server2 = Long Domain Name = STRING	O	O	Struct	-	-

Instance ID	Attribute	Name	Description	Get	Set	Size	Range	Default
1	6	Host Name	Host Name	O	O	STRING	64 Characters	Null

Note: "Get Attributes All" Service shall report in attribute ascending order.

◆ Ethernet Link Object 246 (Class 0xF6)

■ Services Supported

Service Code No. (H)	Service Name
01	Get Attribute All
0E	Get Attribute Single
10	Set Attribute Single

■ Attributes Supported

Instance ID	Attribute	Name	Name	Get	Set	Size	Range	Default
0	1	Object Software Revision	Revision number of the Ethernet Link Object	O	–	Word	–	3
1	1	Interface Speed	Interface speed currently in use	O	–	UDINT	–	–
1	2	Interface Flags	Bit 0 = Link Status Bit 1 = Duplex (0: Half/1: Full) Bits 2-4 = Negotiation Status 0: In progress 1: Auto-negotiate failed 2: Speed found, duplex not found 3: Successful 4: Not attempted Bit 5 = Manual Setting requires restart Bit 6 = Local hardware fault Bits 7-31 = Reserved	O	–	DWord	–	–
1	3	Physical Address (MAC)	MAC address	O	–	Array of 6 Bytes	–	–
1	6	Interface Control	Struct of: Control Bits: Word Bit 0 = Auto-negotiate Bit 1 = Forced Duplex Mode Bits 2-15 = Reserved Forced Int Speed: Word	–	O	Struct	–	–

Note: "Get Attributes All" Service shall report in attribute ascending order.

11 Vendor-Specific (Yaskawa) Class Objects

◆ Yaskawa Drive Parameters Object 100 (Class 0x64)

■ Services Supported

Service Code No. (hex)	Service Name
0E	Get Attribute Single
10	Set Attribute Single

This is a dynamic explicit Class Object. With this Class object any drive parameter or monitor with a MEMOBUS/Modbus address greater than 0x00FF can be accessed. The mapping of Class Object instance/attribute to MEMOBUS/Modbus address is as follows.

Given a typical MEMOBUS/Modbus Address of 0xXXYY

The EtherNet/IP Instance value is equal to XX

The EtherNet/IP Attribute value is equal to YY

As an example, to access parameter b5-12 (MEMOBUS/Modbus Address = 0x01B0)

Class Object is 100 (0x64) (Always for this Class Object)

Instance = 0x01

Attribute = 0xB0

■ Storing Changed Parameters

Writing a zero to 0x0900 (Enter) stores changed parameters to the non-volatile memory of the drive. Writing a 0 to 0x0910 (Accept) allows the drive to use the changed parameters. Reading Enter Command 0x0900 or Accept Command 0x0910 will always return a value of 0x0001.

Performing a RAM-ENTER to Store Register Data

Parameter H5-11 is used to decide whether a RAM-ENTER will be done on the writes to registers in the drive.

If H5-11 = 1 (default), the option will issue the RAM-ENTER with the parameter writes. If H5-11 = 0, no RAM-ENTER is issued and an ENTER command must be explicitly sent by the user for the parameter to be activated after a write.

Explicit writes to RAM-ENTER (0x910) and ROM-ENTER (0x900) are handled as special cases. If a user writes a 0 to RAM-ENTER or ROM-ENTER, the command will be executed in the drive. If a user writes a 1 to those registers, the command will not be executed but returns a success to the explicit write on the network. Writing a value other than 0 or 1 will result in an error response of Invalid Attribute Value on the network.

Note: Performing the RAM-ENTER increases the processing time of the writes and increases the response time to explicit writes.

■ Attributes Supported

Instance ID	Attribute	Name	Description	Get	Set	Size	Range	Default
0	1	Object Software Revision	Yaskawa Drive Parameters object software revision	O	–	Word	–	1
1	00	MEMOBUS/Modbus Register 0x0100	Language selection	O	O	Word	0 to 7	1
1	01	MEMOBUS/Modbus Register 0x0101	Parameter access level	O	O	Word	0 to 2	2
1	YY	MEMOBUS/Modbus Registers 0x0100 to 0x01FF	MEMOBUS/Modbus Registers 0x0100 to 0x01FF	O	O	Word	–	–
2	YY	MEMOBUS/Modbus Registers 0x0200 to 0x02FF	MEMOBUS/Modbus Registers 0x0200 to 0x02FF	O	O	Word	–	–
...	O	Word	–	–
255	YY	MEMOBUS/Modbus Registers 0xFF00 to 0xFFFF	MEMOBUS/Modbus Registers 0xFF00 to 0xFFFF	O	O	Word	–	–

- Note:**
1. Attempting to set a read-only parameter results in an EtherNet/IP error code of 0x0E, Attribute Not Settable.
 2. Attempting to access an invalid parameter results in an EtherNet/IP error code of 0x09, Invalid Attribute Value.
 3. Refer to the MEMOBUS/Modbus Data Table in the MEMOBUS/Modbus Communications chapter of the drive manual for a list of monitor data using the MEMOBUS/Modbus message area.

◆ Yaskawa Monitor/Control Object 125 (Class 0x7D)

■ Services Supported

Service Code No. (hex)	Service Name
0E	Get Attribute Single
10	Set Attribute Single

This is a dynamic explicit Class Object. With this Class object any parameter or monitor with a MEMOBUS/Modbus address less than 0x0100 can be accessed. This class is similar to the Drive Parameters Object Class 100, Object Class 100 differs slightly from Object Class 125. In Object Class 125 the most significant byte of MEMOBUS/Modbus address is always zero and the Instance ID remains at 1.

Given a typical MEMOBUS/Modbus Address of 0x00YY

The EtherNet/IP Instance value is equal to 0x01

The EtherNet/IP Attribute value is equal to YY

As an example, to access Drive Status (MEMOBUS/Modbus Address = 0x002C)

Class Object is 125 (0x7D) (Always for this Class Object)

Instance = 0x01

Attribute = 0x2C

■ Attributes Supported

Instance ID	Attribute	MEMOBUS/Modbus Address	Description	Get	Set	Size	Range	Default
0	1	–	Object Software Revision	O	–	Word	–	1
1	1	0x0001	Drive Command Bits	O	O	Word	–	0
1	2	0x0002	Frequency Instruction	O	O	Word	–	4
..	O	O	Word	–	–
1	255	0x00FF	Unused	O	O	Word	–	–

- Note:**
1. Attempting to set a read-only parameter results in an EtherNet/IP error code of 0x0E, Attribute Not Settable.
 2. Attempting to access an invalid parameter results in an EtherNet/IP error code of 0x09, Invalid Attribute Value.
 3. Refer to the MEMOBUS/Modbus Data Table in the MEMOBUS/Modbus Communications chapter of the drive manual for a list of monitor data using the MEMOBUS/Modbus message area.

12 Web Interface

The web server interface to the option allows management of diagnostic information through a standard web browser. The embedded web pages include:

- Main page (Information)
- Drive Status page (Status, Monitor and Fault History)
- Network Monitor page (Network Monitor)

◆ Main Page (information)

The embedded main page shows basic option information such as vendor ID, serial number, MAC address, and firmware version. This page also shows the status of the option and provides links to the other embedded web pages.

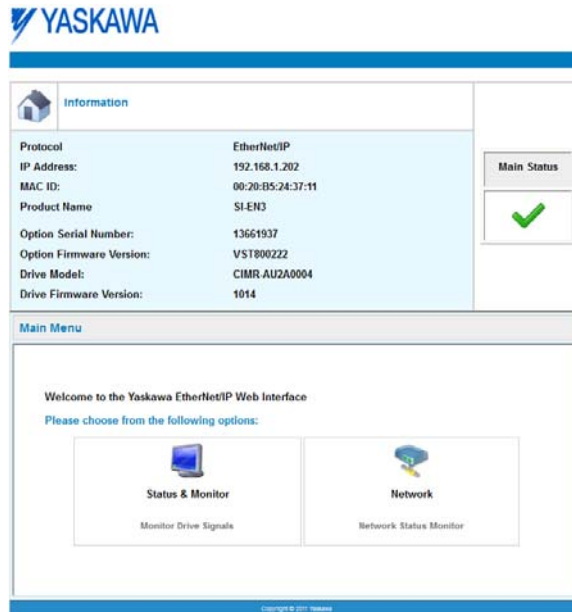

Figure 24 Main Page View

◆ Drive Status Page (Status, Monitor and Fault History)

The embedded drive status page shows basic I/O information and drive state information.

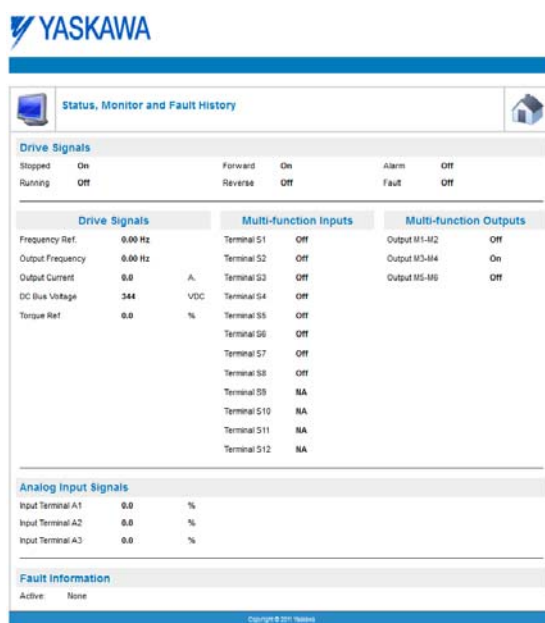

Figure 25 Drive Status Page View

◆ Network Monitor Page (Network Monitor)

The embedded network monitor page shows the status of the option network traffic and open I/O connections.

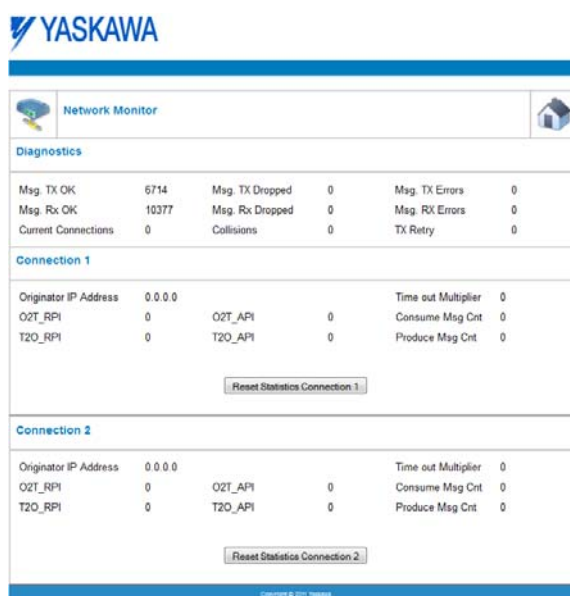

Figure 26 Network Monitor Page View

Table 15 Network Monitor Explanations

Network Monitor	Explanation
Msg Tx OK	Cumulative number of messages transmit successfully from the option.
Msg Rx OK	Cumulative number of messages received successfully to the option.
Current Connections	Current number of open connections.
Msg Tx Dropped	Cumulative number of messages dropped due to output network buffer being full and unable to hold the new message.
Msg Rx Dropped	Cumulative number of messages dropped due to input network buffer being full and unable to hold the new message.
Collisions	Cumulative number of collisions.
Msg Tx Errors	Cumulative number of transmit errors.
Msg Rx Errors	Cumulative number of receive errors.
Tx Retry	Cumulative number of transmit errors.
Originator IP Address	The IP address of the network node making this connection.
Time out Multiplier	The value here specifies the multiplier applied to the expected packet rate (API) to obtain the value used by the inactivity timer for this connection.
O2T_RPI	Originator to Target (ie, PLC to SI-EN3) Requested Packet Interval for I/O messaging, in milliseconds, for this connection.
O2T_API	Originator to Target (ie, PLC to SI-EN3) Actual Packet Interval for I/O messaging, in milliseconds, for this connection.
Consume Msg Cnt	Number of I/O messages consumed (ie, received) from the SI-EN3 since the connection was established or statistics were reset for this connection.
T20_RPI	Target to Originator (ie, SI-EN3 to PLC) Requested Packet Interval for I/O messaging, in milliseconds, for this connection.
T20_API	Target to Originator (ie, SI-EN3 to PLC) Actual Packet Interval for I/O messages, in milliseconds, for this connection.
Produce Msg Cnt	Number of IO messages produced (ie, transmit) from the SI-EN3 since the connection was established or statistics were reset for this connection.
Reset Statistics Connection1	Clicking this resets the Consume Msg Cnt and the Produce Msg Cnt for this connection to start counting from zero.

Note: Network monitors are reset when the power supply is cycled.

13 Troubleshooting

◆ Drive-Side Error Codes

Drive-side error codes appear on the drive keypad. [Table 16](#) lists causes of the errors and possible corrective actions. Refer to the drive Technical Manual for additional error codes that may appear on the drive keypad.

■ Faults

Both bUS (Option Communication Error) and EF0 (Option Card External Fault) can appear as an alarm or as a fault. When a fault occurs, the keypad ALM LED remains lit. When an alarm occurs, the ALM LED flashes.

If communication stops while the drive is running, use the following questions as a guide to help remedy the fault:

- Is the option properly installed?
- Is the communication line properly connected to the option? Is it loose?
- Is the controller program working? Has the controller/PLC CPU stopped?
- Did a momentary power loss interrupt communications?

Table 16 Fault Display and Possible Solutions

Keypad Display		Fault Name
<i>bUS</i>	bUS	Option Communication Error
		<ul style="list-style-type: none"> • After establishing initial communication, the connection was lost. • Only detected when the run command or frequency reference is assigned to the option (b1-01 = 3 or b1-02 = 3).
Cause		Possible Solution
No signal was received from the PLC.		<ul style="list-style-type: none"> • Check for faulty wiring. • Correct any wiring problems.
Faulty communications wiring.		
An existing short circuit or communications disconnection.		Check disconnected cables and short circuits and repair as needed.
A data error occurred due to electric interference.		<ul style="list-style-type: none"> • Counteract noise in the control circuit, main circuit, and ground wiring. • If a magnetic contactor is identified as a source of noise, install a surge absorber to the contactor coil. • Use only recommended cables or other shielded line. Ground the shield on the controller side or the drive input power side. • Separate all communication wiring from drive power lines. Install an EMC noise filter to the drive power supply input. • Counteract noise in the master controller (PLC).
The option is not properly connected to the drive.		Reinstall the option.
Option is damaged.		If there are no problems with the wiring and the error continues to occur, replace the option.
Connection Time-out		The option Requested Packet Interval (RPI) timer timed out
Duplicate IP Address		Check if the option shares IP Address with at least one other node. Check the setting values of F7-01 to F7-04 (IP Address).
Keypad Display		Fault Name
<i>EF0</i>	EF0	Option Card External Fault
		The alarm function for an external device has been triggered.
Cause		Corrective Action
An external fault was received from the PLC.		<ol style="list-style-type: none"> 1. Remove the cause of the external fault. 2. Reset the external fault input from the PLC.
Problem with the PLC program		Check the PLC program.
PLC is in the Idle Mode.		Set the PLC to the Run Mode
Keypad Display		Fault Name
<i>oFA00</i>	oFA00	Option Card Connection Error (CN5-A)
		Option is not properly connected.
Cause		Possible Solution
The option card installed into port CN5-A is incompatible with the drive.		Connect the option to the correct option port. Note: PG option cards are supported by option ports CN5-B and CN5-C only.

13 Troubleshooting

Keypad Display		Fault Name	
oFA01	oFA01	Option Card Fault (CN5-A)	
		Option is not properly connected.	
Cause		Possible Solution	
The option connected to option port CN5-A was changed during run.		De-energize the drive and plug the option into the drive according to Installation Procedure on page 11 .	
Keypad Display		Fault Name	
oFA03, oFA04	oFA03, oFA04	Option Card Error (CN5-A)	
		Option Card Error (CN5-A)	
Cause		Possible Solution	
A fault occurred in the option.		<ol style="list-style-type: none"> 1. De-energize the drive. 2. Make sure that the option is correctly connected to the connector. 3. If the problem continues, replace the option. 	
Keypad Display		Fault Name	
oFA30 to oFA43	oFA30 to oFA43	Option Card Connection Error (CN5-A)	
		Communication ID error.	
Cause		Possible Solution	
The option card connection to port CN5-A is faulty.		<ol style="list-style-type: none"> 1. Turn off the power. 2. Check if the option is properly plugged into the option port. 3. Replace the option if the fault continues to occur. 	
Keypad Display		Fault Name	
oFb00	oFb00	Option Fault (CN5-B)	
		Non-compatible option is connected.	
Cause		Possible Solution	
The option card installed into port CN5-B is incompatible with the drive.		Connect the option to the correct option port. Note: Use connector CN5-B when connecting DO-A3, AO-A3, or two PG options. Use connector CN5-C when connecting only one PG option.	
Keypad Display		Fault Name	
oFb02	oFb02	Option Fault (CN5-B)	
		Two identical options are connected at the same time.	
Cause		Possible Solution	
An option of the same type is already installed in option port CN5-A, CN5-B, or CN5-C.		Connect the option to the correct option port.	
Keypad Display		Fault Name	
oFc00	oFc00	Option Fault (CN5-C)	
		Non-compatible option is connected.	
Cause		Possible Solution	
The option card installed into port CN5-C is incompatible with the drive.		Connect the option to the correct option port. Note: AI-A3, DI-A3, and communication options are not supported by option port CN5-C.	
Keypad Display		Fault Name	
oFc02	oFc02	Option Fault	
		Option Flash write mode.	
Cause		Possible Solution	
An option of the same type is already installed in option port CN5-A, CN5-B, or CN5-C.		Connect the option to the correct option port.	

■ Minor Faults and Alarms

Keypad Display		Minor Fault Name	
CyPo	CyPo	Cycle Power to Active Parameters	
		Comm. Option Parameter Not Upgraded	
Cause		Possible Solution	Minor Fault (H2-□□ = 10)
Although F6-15 = 1 [Comm. Option Parameters Reload = Reload Now], the drive did not update the communication option parameters.		Re-energize the drive to update the communication option parameters. Note: If the option software version is not compatible or if you install an incorrect option to the drive, it will trigger an alarm.	YES

■ Explicit Message Communications Errors

When there is a problem with a request message sent from the master in explicit communications, the drive will return one of the following error codes.

Error Code (hex)	Description	Cause	Possible Solution
08	Service not supported	The service code is incorrect.	Correct the service code.
09	Invalid attribute value	The attribute is incorrect.	Correct the attribute.
0C	Object state conflict	Attempted to change an drive constant that cannot be changed while the drive is running.	Stop the drive.
0E	Attribute not settable	Attempted to change a read-only attribute.	Correct the service code or attribute setting.
13	Not enough data	The data size is incorrect.	Correct the data size.
14	Attribute not supported	Attempted to execute a service not defined for the attribute.	Correct the service code or attribute setting.
15	Too much data	The data size is incorrect.	Correct the data size.
16	Object does not exist	An unsupported object was specified.	Correct the class or instance setting.
1F	Vendor-specific error	Attempted to change a drive constant that cannot be changed while the drive is running. Attempted to change a drive constant to a value outside the setting range.	Stop the drive. Specify a value within the setting range.
20	Invalid parameter	Attempted to change to a data value outside the setting range.	Specify a data value within the setting range.

◆ Option Error Codes

■ Option Fault Monitors U6-98 and U6-99

The option can declare error/warning conditions via drive monitor parameters on the drive keypad as shown in [Table 17](#).

Table 17 Option Fault Monitor Descriptions

Fault Condition	Fault Declared	Status Value (U6-98/U6-99)	Description
No Fault	n/a	0	No faults.
Force Fault	EF0	3	Network sent a message to force this node to the fault state.
Network Link Down	BUS ERROR	1100	No network link to option.
Connection Time-out	BUS ERROR	1101	The node timer (Requested Packet Interval) timed out.
Duplicate IP Address	BUS ERROR	1102	This node and at least one other node have the same IP Address.
Default MAC Address	None	1103	Factory default MAC Address programmed into the option. Return for reprogramming.

Two drive monitor parameters, U6-98 and U6-99 assist the user in network troubleshooting.

- U6-98 displays the first declared fault since the last power cycle. U6-98 is only cleared upon drive power-up.
- U6-99 displays the present option status. U6-99 is cleared upon a network-issued fault reset and upon power-up.

If another fault occurs while the original fault is still active, parameter U6-98 retains the original fault value and U6-99 stores the new fault status value.

◆ Option Compatibility

Users may connect up to 3 options simultaneously depending on the type of option. Refer to [Table 18](#) for details.

Note: You can only connect one option to the GA500. Connect the option card to the CN5 connector.

Table 18 Option Compatibility

Option Card	Connector	Number of Cards Possible
PG-B3, PG-X3	CN5-B, C	2 <1>
PG-RT3 <2> <3>, PG-F3 <2> <3>	CN5-C	1
DO-A3, AO-A3	CN5-A, B, C	1
SI-C3, SI-N3, SI-P3, SI-S3, SI-T3, SI-ET3, SI-ES3, SI-B3, SI-M3, SI-W3 <3>, SI-EM3 <3>, SI-EN3 <3>, SI-EP3, AI-A3 <4>, DI-A3 <4>, SI-EN3D, SI-EM3D	CN5-A	1

<1> When connecting two PG option cards, use both CN5-B and CN5-C. When connecting only one PG option card, use the CN5-C connector.

<2> Not available for the application with Motor 2 Selection.

<3> Not available with 1000-Series drive models with a capacities between 450 and 630 kW.

<4> When you use the input status of AI-A3 and DI-A3 as a monitor, you can connect AI-A3 and DI-A3 to CN5-A, CN5-B, or CN5-C.

14 Option Installation

Verify the following installation conditions to suppress the radiated emissions from other devices and machinery used with this option and drives:

1. Use dedicated shield cable for the option and external device (encoder, I/O device, master), or run the wiring through a metal conduit.
2. Keep wiring as short as possible and ground the largest possible surface area of the shield to the metal panel according to [Figure 28](#).

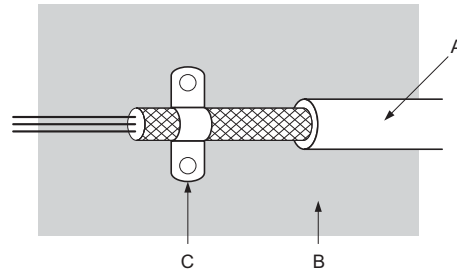

A – Braided shield cable **C – Cable clamp (conductive)**
B – Metal panel

Figure 27 Ground Area

■ Option Installation: Models PG-□□, DI-□□, DO-□□, AI-□□, AO-□□, SI-□□

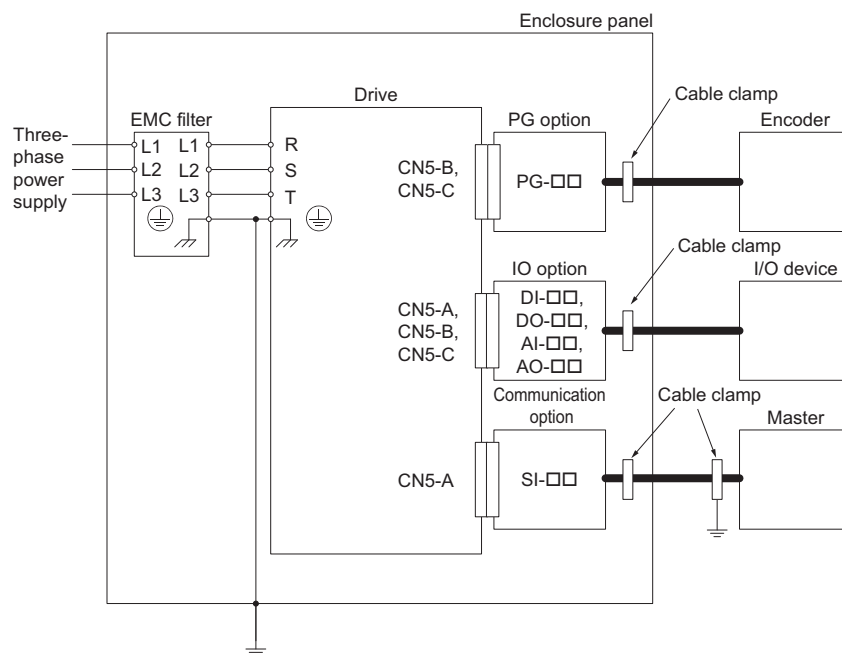

Figure 28 Option Installation (PG-□□, DI-□□, DO-□□, AI-□□, AO-□□, SI-□□)

■ Option Installation for GA500

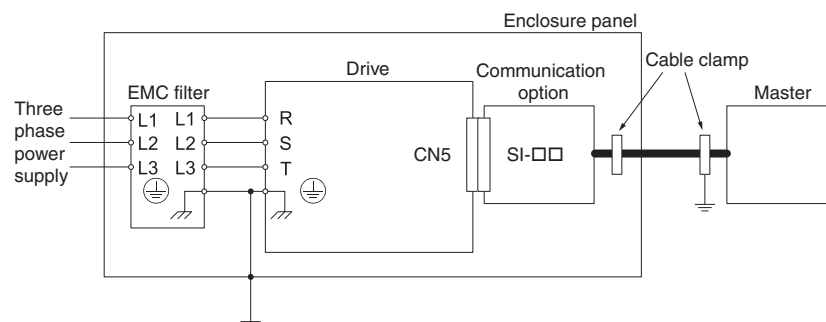

Figure 29 Option Installation for GA500

15 Specifications

Table 19 Option Specifications

Item	Specification
Model	SI-EN3
Supported Messages	<ul style="list-style-type: none"> • Explicit: Explicit Class 3, Unconnected • I/O: Class 1, Listen Only, Input Only
I/O Assembly Instance	<ul style="list-style-type: none"> • Input: 12 types (4 to 44 Bytes) • Output: 12 types (4 to 44 Bytes)
SI-EN3 Specification	Conformance Level CT 12: Passed
SI-EN3 Profile	AC Drive
Connector Type	RJ45 8-pin Straight Connector STP Cat5e cable
Physical Layer Type	<ul style="list-style-type: none"> • Isolated Physical Layer • TCP Protocol Transformer Isolated
IP Address Setting	Programmable from drive keypad or network
Communication Speed	Programmable from drive keypad or network: 10/100 Mbps, auto-negotiate
Number of Connections	<ul style="list-style-type: none"> • I/O: 2 • Explicit: 6
Duplex Mode	Half-forced, Auto-negotiate, Full-forced
Address Startup Mode	Static, BOOTP, DHCP
Ambient Temperature	-10°C to +50°C (14°F to 122°F)
Humidity	95% RH or lower with no condensation
Storage Temperature	-20°C to +60°C (-4°F to 140°F) allowed for short-term transport of the product
Area of Use	Indoors and free from: <ul style="list-style-type: none"> • Oil mist, corrosive gas, flammable gas, and dust • Radioactive materials or flammable materials, including wood • Harmful gas or fluids • Salt • Direct sunlight • Falling foreign objects
Altitude	1000 m (3280 ft) or lower

16 Disposal

◆ Disposal Instructions

Correctly dispose of this product and packing material as specified by applicable regional, local, and municipal laws and regulations.

◆ WEEE Directive



Figure 30 WEEE Mark

The wheeled bin symbol on this product, its manual, or its packaging identifies that you must recycle it at the end of its product life.

You must discard the product at an applicable collection point for electrical and electronic equipment (EEE).

Do not discard the product with usual waste.

◆ Revision History

Revision dates and manual numbers appear on the bottom of the back cover.

MANUAL NO. SIEP C730600 92B <1>

Published in Japan August 2018

Revision number

Date of publication

Date of Publication	Revision Number	Section	Revised Content
March 2019	<3>	All	Addition: Applicable product series Revision: Reviewed and corrected entire documentation.
		Chapter 16	Addition: Disposal
February 2019	<2>	All	Addition: Applicable product series Revision: Reviewed and corrected entire documentation.
		Back cover	Revision: Address
August 2018	<1>	All	Addition: Applicable product series
		Back cover	Revision: Address
July 2016	–	–	First edition

YASKAWA AC Drive Option

EtherNet/IP

Technical Manual

DRIVE CENTER (INVERTER PLANT)

2-13-1, Nishimiyaichi, Yukuhashi, Fukuoka, 824-8511, Japan
Phone: +81-930-25-2548 Fax: +81-930-25-3431
<http://www.yaskawa.co.jp>

YASKAWA ELECTRIC CORPORATION

New Pier Takeshiba South Tower, 1-16-1, Kaigan, Minatoku, Tokyo, 105-6891, Japan
Phone: +81-3-5402-4502 Fax: +81-3-5402-4580
<http://www.yaskawa.co.jp>

YASKAWA AMERICA, INC.

2121, Norman Drive South, Waukegan, IL 60085, U.S.A.
Phone: +1-800-YASKAWA (927-5292) or +1-847-887-7000 Fax: +1-847-887-7310
<http://www.yaskawa.com>

YASKAWA ELÉTRICO DO BRASIL LTDA.

777, Avenida Piraporinha, Diadema, São Paulo, 09950-000, Brasil
Phone: +55-11-3585-1100 Fax: +55-11-3585-1187
<http://www.yaskawa.com.br>

YASKAWA EUROPE GmbH

Hauptstraße 185, 65760 Eschborn, Germany
Phone: +49-6196-569-300 Fax: +49-6196-569-398
<http://www.yaskawa.eu.com> E-mail: info@yaskawa.eu.com

YASKAWA ELECTRIC KOREA CORPORATION

35F, Three IFC, 10 Gukjegeumyung-ro, Yeongdeungpo-gu, Seoul, 07326, Korea
Phone: +82-2-784-7844 Fax: +82-2-784-8495
<http://www.yaskawa.co.kr>

YASKAWA ASIA PACIFIC PTE. LTD.

30A, Kallang Place, #06-01, 339213, Singapore
Phone: +65-6282-3003 Fax: +65-6289-3003
<http://www.yaskawa.com.sg>

YASKAWA ELECTRIC (THAILAND) CO., LTD.

59, 1st-5th Floor, Flourish Building, Soi Ratchadapisek 18, Ratchadapisek Road, Huaykwang, Bangkok, 10310, Thailand
Phone: +66-2-017-0099 Fax: +66-2-017-0799
<http://www.yaskawa.co.th>

YASKAWA ELECTRIC (CHINA) CO., LTD.

22F, Link Square 1, No.222, Hubin Road, Shanghai, 200021, China
Phone: +86-21-5385-2200 Fax: +86-21-5385-3299
<http://www.yaskawa.com.cn>

YASKAWA ELECTRIC (CHINA) CO., LTD. BEIJING OFFICE

Room 1011, Tower W3 Oriental Plaza, No. 1, East Chang An Ave.,
Dong Cheng District, Beijing, 100738, China
Phone: +86-10-8518-4086 Fax: +86-10-8518-4082

YASKAWA ELECTRIC TAIWAN CORPORATION

12F, No. 207, Sec. 3, Beishin Rd., Shindian Dist., New Taipei City 23143, Taiwan
Phone: +886-2-8913-1333 Fax: +886-2-8913-1513 or +886-2-8913-1519
<http://www.yaskawa.com.tw>

YASKAWA INDIA PRIVATE LIMITED

#17/A, Electronics City, Hosur Road, Bangalore, 560 100 (Karnataka), India
Phone: +91-80-4244-1900 Fax: +91-80-4244-1901
<http://www.yaskawaindia.in>

YASKAWA

YASKAWA ELECTRIC CORPORATION

In the event that the end user of this product is to be the military and said product is to be employed in any weapons systems or the manufacture thereof, the export will fall under the relevant regulations as stipulated in the Foreign Exchange and Foreign Trade Regulations. Therefore, be sure to follow all procedures and submit all relevant documentation according to any and all rules, regulations and laws that may apply.

Specifications are subject to change without notice for ongoing product modifications and improvements.

© 2016 YASKAWA ELECTRIC CORPORATION

MANUAL NO. SIEP C730600 92D <3>-0

Published in Japan March 2019
18-11-20