

YASKAWA

EtherCAT Option

Options Card for AC Drives and Regenerative Units
Installation Manual

Type: SI-ES3
SI-ES3/V

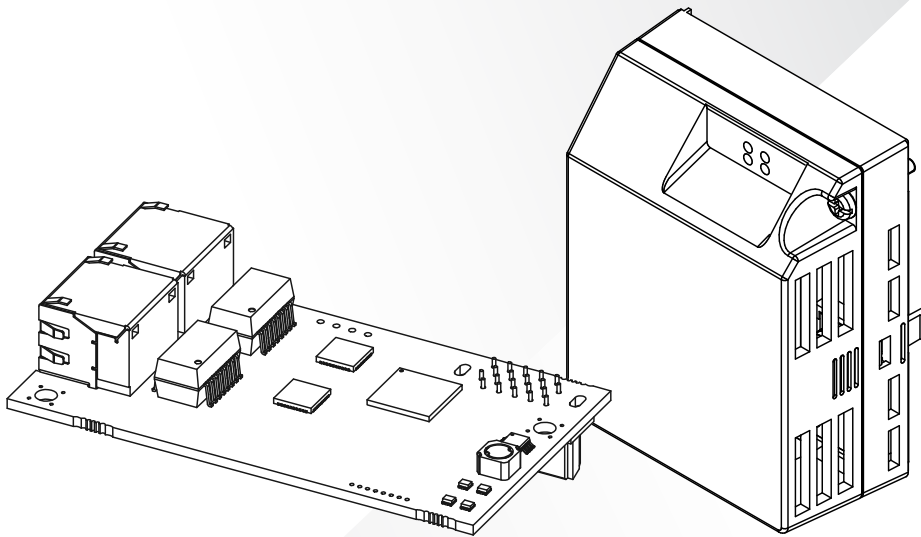
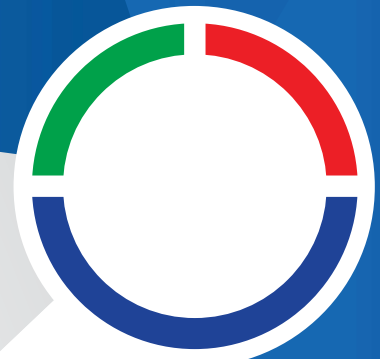

This Page Intentionally Blank

Table of Contents

1. Preface and General Precautions	5
Safety Information	5
General Safety Instructions	5
Intended Use	6
Legal Information	7
2. Product Overview	7
About This Product	7
Applicable Models	7
3. Receiving	8
4. EtherCAT Option Components	9
EtherCAT Option SI-ES3.	9
EtherCAT Option SI-ES3/V for V1000	9
EtherCAT Option Status LEDs	10
Indicator Flash Rates	11
Connecting the Option Card	11
5. Mechanical & Electrical Installation	12
Safety Precautions	12
Preconditions for Installing the Option Card	13
Installing the Option on a A1000, D1000, R1000 or U1000	13
Installing the Option on a V1000.	14
Installing the Option on a GA700	16
Installing the Option on a Q2A	18
ESI File.	20
6. EtherCAT Option Related Drive Parameters	21
Parameters for A1000, D1000, R1000, U1000, GA700, V1000.	21
Parameters for Q2A.	22
7. Troubleshooting	23
Communication Option Card Error Codes	23
Yaskawa-specific SDO Abort Codes	23
Faults	23
Minor Faults/Alarms	24
8. Specifications	25
9. Glossary	25

Index.....	26
Revision History.....	27

1 Preface and General Precautions

This chapter describes important safety precautions regarding the use of this product. Failure to follow these precautions may result in serious injury or death, and may lead to damage to this product or related devices and systems. Yaskawa shall not be held responsible for any injury or equipment damage as a result of failure to observe the precautions and instructions contained in this manual.

◆ Safety Information

Read and understand this manual before you install, operate, or do maintenance on the drive. Install the drive as specified by this manual and local codes.

The symbol marks in this section identify safety messages in this manual. Failure to obey these safety messages can cause serious injury, death, or damage to the products and related equipment and systems.

These identifier words categorize and emphasize important safety precautions in these instructions.

⚠ DANGER Identifies a hazardous situation, which, if not avoided, will cause death or serious injury.

⚠ WARNING Identifies a hazardous situation, which, if not avoided, can cause death or serious injury.

⚠ CAUTION Identifies a hazardous situation, which, if not avoided, can cause minor or moderate injury.

NOTICE Identifies a property damage message.

■ General Safety Instructions

Yaskawa Electric manufactures and supplies electronic components for a variety of industrial applications. The selection and application of Yaskawa products is the responsibility of the designer of the equipment or the customer that assembles the final product. Yaskawa is not responsible for how our products are incorporated into the final system design. In all cases, Yaskawa products should not be incorporated into a product or design as the exclusive or sole safety control function. All control functions are designed to dynamically detect failures and operate safely without exception. All products that are designed to incorporate parts manufactured by Yaskawa must be provided to the end user and include proper warnings and instructions regarding their safe use and operation. All warnings from Yaskawa must be promptly issued to the end user. Yaskawa offers warranties only for the quality of our products, in compliance with standards and specifications that are described in the manual. Yaskawa does not offer other warranties, either explicit or implied. Yaskawa assumes no responsibility for personal injury, property damage or loss, or compensation for damage caused by the incorrect application of our products.

Note:

Be aware that serious injury or death may result if the warnings described in this manual are not observed. Yaskawa assumes no responsibility for injuries or equipment damage to your company or customers that are caused by a failure to observe the information contained in this manual.

- Read this manual carefully when mounting, operating, and repairing AC drives and Communication options.
- Follow all warnings, cautions, and instructions.
- All work should be carried out by qualified personnel.
- Ensure the drive is installed to an area that matches the following conditions.

⚠ DANGER *Electrical Shock Hazard. Do not examine, connect, or disconnect wiring on an energized drive. Before servicing, disconnect all power to the equipment and wait for the time specified on the warning label at a minimum. The internal capacitor stays charged after the drive is de-energized. The charge indicator LED extinguishes when the DC bus voltage decreases below 50 Vdc. When all indicators are OFF, remove the covers before measuring for dangerous voltages to make sure that the drive is safe. Failure to obey will cause death or serious injury.*

⚠ WARNING *Fire Hazard. Do not connect power supply wiring to drive output terminals U/T1, V/T2, and W/T3. Connect power supply wiring to main circuit input terminals R/L1, S/L2, and T/L3. Failure to obey can cause death or serious injury.*

⚠ WARNING *Electrical Shock Hazard. Do not make changes to the drive body or drive circuitry. Failure to obey can cause death or serious injury and will void warranty. Yaskawa is not responsible for changes to the product made by the user.*

⚠ WARNING *Electrical Shock Hazard. Only let authorized persons install, wire, maintain, examine, replace parts, and repair the drive. Failure to obey can cause death or serious injury.*

⚠ WARNING *Electrical Shock Hazard. Always ground the motor-side grounding terminal. Contacting the motor case can cause death or serious injury from incorrect equipment grounding.*

⚠ WARNING *Electrical Shock Hazard. Do not work on the drive or around the drive while wearing loose clothing or jewelry. Tighten loose clothing and remove all metal objects such as watches or rings. Failure to obey can cause death or serious injury.*

⚠ WARNING *Electrical Shock Hazard. The leakage current of the drive will be more than 3.5 mA in drive models 2xxxB, 2xxxC, 4002B to 4371B, 4002C to 4371C (with built-in EMC filter turned ON) and 4389 to 4675. The IEC/EN 61800-5-1: 2007 standard specifies that users must wire the power supply to automatically turn off when the protective ground wire disconnects. Users can also connect a protective ground wire that has a minimum cross-sectional area of 10 mm² (copper wire) or 16 mm² (aluminum wire). Failure to obey these standards can cause death or serious injury.*

⚠ WARNING *Sudden Movement Hazard. Remove all persons and objects from the area around the drive, motor, and load before starting Auto-Tuning. The drive and motor can start suddenly during Auto-Tuning and cause death or serious injury.*

⚠ WARNING *Sudden Movement Hazard. Remove all persons and objects from the area around the drive, motor, and machine area and attach covers, couplings, shaft keys, and machine loads before energizing the drive. Failure to obey can cause death or serious injury.*

⚠ WARNING *Fire Hazard. Do not use the main circuit power supply (Overcurrent Category III) at incorrect voltages. Make sure that the drive rated voltage aligns with the power supply voltage before energizing the drive. Failure to obey can cause death or serious injury.*

⚠ WARNING *Fire Hazard. Do not put flammable or combustible materials on top of the drive and do not install the drive near flammable or combustible materials. Attach the drive to metal or other noncombustible material. Failure to obey can cause death or serious injury.*

⚠ WARNING *Fire Hazard. Tighten all terminal screws to the correct tightening torque. Connections that are too loose or too tight can cause incorrect operation and damage to the drive. Incorrect connections can also cause death or serious injury from fire.*

⚠ WARNING *Electrical Shock Hazard. Do not cause a short circuit on the drive output circuit. Failure to obey can cause death or serious injury.*

⚠ WARNING *Electrical Shock Hazard. Always use a type B Residual Current Monitor/Residual Current Device (RCM/RCD) where a residual current operated protective or monitoring device protects against direct or indirect contact as specified by IEC/EN 60755. The drive can cause a residual current with a DC component in the protective earthing conductor. Failure to obey can cause death or serious injury.*

⚠ WARNING *Electrical Shock Hazard. Ground the neutral point on the power supply of drive models 2xxxB/C and 4xxxA/B/C to comply with the EMC Directive before turning on the EMC filter or if there is high resistance grounding. If the EMC filter is switched ON without the neutral point being grounded or if there is high resistance grounding, it can cause death or serious injury.*

⚠ WARNING *Electrical Shock Hazard. Do not immediately energize the drive or operate peripheral devices after the drive blows a fuse or trips an RCM/RCD. Wait for the time specified on the warning label at a minimum and make sure that all indicators are OFF. Then check the wiring and peripheral device ratings to find the cause of the problem. Contact Yaskawa before energizing the drive or peripheral devices if the cause is not known. Failure to obey can cause death or serious injury and damage to the drive.*

⚠ WARNING *Fire Hazard. Install sufficient branch circuit short circuit protection as specified by applicable codes and this manual. The drive is suited for circuits that supply not more than 100,000 RMS symmetrical amperes, 240 Vac maximum (200 V Class), 480 Vac maximum (400 V Class). Failure to obey can cause death or serious injury.*

⚠ CAUTION *Burn Hazard. Do not touch a hot drive heatsink. De-energize the drive, wait 15 minutes minimum, and make sure that the heatsink is cool to replace the cooling fans. Failure to obey can cause minor to moderate injury.*

NOTICE *Observe correct electrostatic discharge (ESD) procedures when touching the drive and circuit boards. Failure to obey can cause ESD damage to the drive circuitry.*

NOTICE *Do not connect or disconnect the motor from the drive while the drive is supplying voltage. Incorrect equipment sequencing can cause damage to the drive.*

NOTICE *Do not do a withstand voltage test or Megger test on the drive. Failure to obey can cause damage to the drive.*

NOTICE *Do not connect or operate damaged equipment or equipment with missing parts. Failure to obey can cause damage to the drive and connected equipment.*

NOTICE *Install fuses and an RCM/RCD. Failure to obey can cause damage to the drive.*

NOTICE *Do not use unshielded wire for control wiring. Use shielded, twisted-pair wires and ground the shield to the ground terminal of the drive. Failure to obey can cause electrical interference and unsatisfactory system performance.*

NOTICE *Make sure that all connections are correct after you install the drive and connecting peripheral devices. Failure to obey can cause damage to the drive.*

■ Intended Use

This communication option card is electrical equipment intended to enable Yaskawa drives to communicate with an additional fieldbus system for commercial use. Do not use this product for any other purpose.

1. Read and understand all safety precautions.
2. Wire and ground the drive and communication option card in accordance with all applicable standards and safety precautions.

3. Firmly attach all parts and protective covers.
4. Always use the product in the proper environmental conditions as specified in this manual.

⚠ DANGER *Electrical Shock Hazard. Make sure that all electrical connections are correct and install all drive covers before energizing the drive. Use terminals for their intended function only. Incorrect wiring or ground connections, and incorrect repair of protective covers can cause death or serious injury.*

⚠ WARNING *Electrical Shock Hazard. Do not make changes to the drive body or drive circuitry. Failure to obey can cause death or serious injury and will void warranty. Yaskawa is not responsible for changes to the product made by the user.*

◆ Legal Information

■ Exclusion of Liability

This product is not designed and manufactured for use in life-support machines or systems.

Contact a Yaskawa representative or your Yaskawa sales representative if you are considering the application of this product for special purposes, such as machines or systems used for passenger cars, medicine, airplanes and aerospace, nuclear power, electric power, or undersea relaying.

⚠ WARNING *Injury to Personnel. Yaskawa manufactured this product with strict quality-control guidelines. Install applicable safety devices to minimize the risk of accidents when installing the product where its failure could cause a life-or-death situation, loss of human life, or a serious accident or physical injury.*

■ About Registered Trademarks

- EtherCAT® is a registered trademark of Beckhoff Automation GmbH.
- Other company names and product names that appear in this document are trademarks or registered trademarks of the respective companies.

2 Product Overview

◆ About This Product

The EtherCAT Communication Option (Models: SI-ES3 and SI-ES3/V) is an option card designed to connect the YASKAWA AC drives or regenerative units to an EtherCAT network. Using this option card and an EtherCAT master you can:

- Operate the AC drive or regenerative unit
- Monitor the AC drive or regenerative unit operation status
- Read or modify AC drive or regenerative unit parameters.

The option contains support for the Velocity mode according the CANopen Device Profile and Motion Control (DSP402) profile. It also contains YASKAWA vendor specific CANopen objects based on the present CANopen option board specification.

The EtherCAT Option supports the following communication profiles:

- DS 301 Ver. 4.02
- DSP 402 Ver. 3.0 Velocity Mode (not available for D1000 and R1000)



EtherCAT®

◆ Applicable Models

The option can be used with these drive series:

Table 2.1 Applicable Models

Option Card Model	Drive Series	Software Version
SI-ES3	A1000	For models up to 630 kW: VSA901017 and higher For models more than 630 kW: VSA903015 and higher
	D1000	For models up to 630 kW: VSD902006 and higher For models more than 630 kW: VSD903014 and higher
	R1000	VSD902102 and higher
	U1000	VSU901010 and higher
	GA700	VSAA1010 and higher
	Q2A	VSAA923010 and higher
SI-ES3/V	V1000	VSV901020 and higher

For software version, see “PRG” on the nameplate of the drive or regenerative unit.

3 Receiving

Please perform the following tasks after receiving the Communication Option card:

- Inspect the Communication Option card for damage. If the Communication Option card appears damaged upon receipt, contact the shipping company immediately.
- Verify receipt of the correct model by checking the information:
For V1000: Find the information on the mounting frame label of the option card.
For other units: Find the information on the PCB.
- If you have received the wrong option card model or the Communication Option card does not function properly, contact your supplier.

◆ Packaging Content

Table 3.1 Option Package Contents for SI-ES3 (AC Drives and Regenerative Units)





Description	Option Card	Ground Cables	Screws (M3)	LED Label	Installation Manual
Illustration					
Quantity	1	1	3	2	1

Table 3.2 Option Package Contents for SI-ES3/V (V1000 AC Drive)

Description	Option Card	Ground Cables	Installation Manual
Illustration			
Quantity	1	4; of different length	1

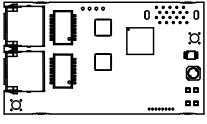
4 EtherCAT Option Components

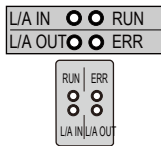
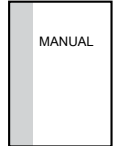
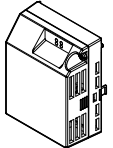
◆ EtherCAT Option SI-ES3

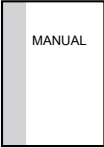
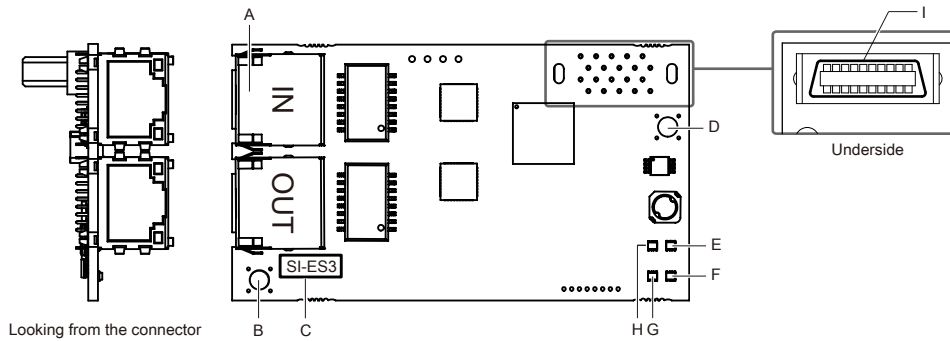

- | | |
|---|----------------------------|
| A - Communication cable connector (RJ45) | F - LED (ERR) |
| B - Ground terminal (installation hole) | G - LED (L/A OUT) |
| C - Model number | H - LED (L/A IN) |
| D - Installation hole | I - Connector (CN5) |
| E - LED (RUN) | |

Figure 4.1 Option Card

◆ EtherCAT Option SI-ES3/V for V1000

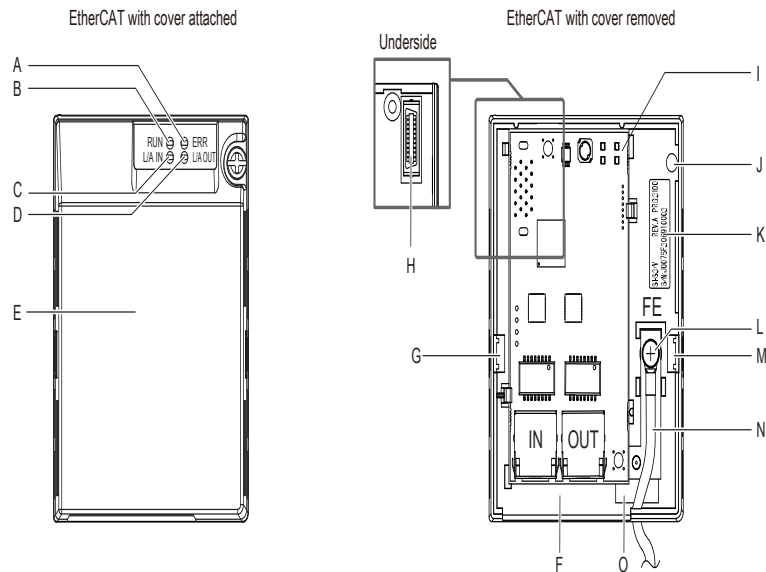

- | | |
|---|---|
| A - LED (ERR) | I - Option Card PCB |
| B - LED (RUN) | J - Attachment screw hole for option cover |
| C - LED (L/A IN) | K - Nameplate |
| D - LED (L/A OUT) | L - Ground terminal (FE) |
| E - Option Cover | M - Mounting clip |
| F - Communication cable connector (RJ45) | N - Wire |
| G - Mounting clip | O - Through-hole for wire |
| H - Connector (CN5) | |

Figure 4.2 Option Card for V1000

◆ EtherCAT Option Status LEDs

The EtherCAT Option has four LEDs that indicate the communication status. The indications conform with DS303, Part 3: Indicator Specification.

■ LEDs L/A OUT and L/A IN: Ethernet Link/Activity 1 and 2

The Link/Activity indicators show the status of the physical link and show activity on the link period.

LED	Color	Display	Meaning
Link Activity 1/2	–	Off	No link. The communication cable is not physically connected. The communication controller is not started up.
	Green	On	The module is connected to Ethernet. A communication cable is physically connected, but no data is being exchanged.
	Green	Flickering	There is traffic on Ethernet, data is being exchanged.

■ RUN LED

A green lit RUN LED indicates the status of the communication network state machine.

A red lit RUN LED is only used by the NOID firmware loader.

LED	Color	Display	Meaning
RUN	–	Off	The device is in Init state.
	Green	Blinking	The device is in Pre-Operational State.
	Green	Single flash	The device is in Safe-Operational State.
	Green	On	The device is in Operational State.
	Red	Blinking (1 Hz or 6 Hz)	The Option BOOT or APP firmware is executing the NOID firmware loader. 1 Hz: Firmware loader protocol in IDLE state (waiting for commands from the drive) 6 Hz: Firmware loader protocol is processing commands

■ ERR LED

The red error LED indicates the presence of any errors.

LED	Color	Display	Meaning
ERR	–	Off	No link. The communication option card is in working condition.
	Red	Blinking	General configuration error.
		Single flash	The slave device application has changed the communication state autonomously: The parameter "Change" in the AL status register is set to 01 (Hex): change/error.
		Double flash	The sync manager watchdog time out has occurred.
		On	Possible causes: 1: A Process Data Interface error has occurred, the NOID application interface has failed. 2: An option card FATAL event has occurred (system has stalled execution, see object 4000 (Hex) for the cause).
		Blinking (1 Hz or 6 Hz)	The option BOOT or APP firmware is executing the NOID firmware loader. 1 Hz: Firmware loader protocol in IDLE state (waiting for commands from drive) 6 Hz: Firmware loader protocol is processing commands

Indicator Flash Rates

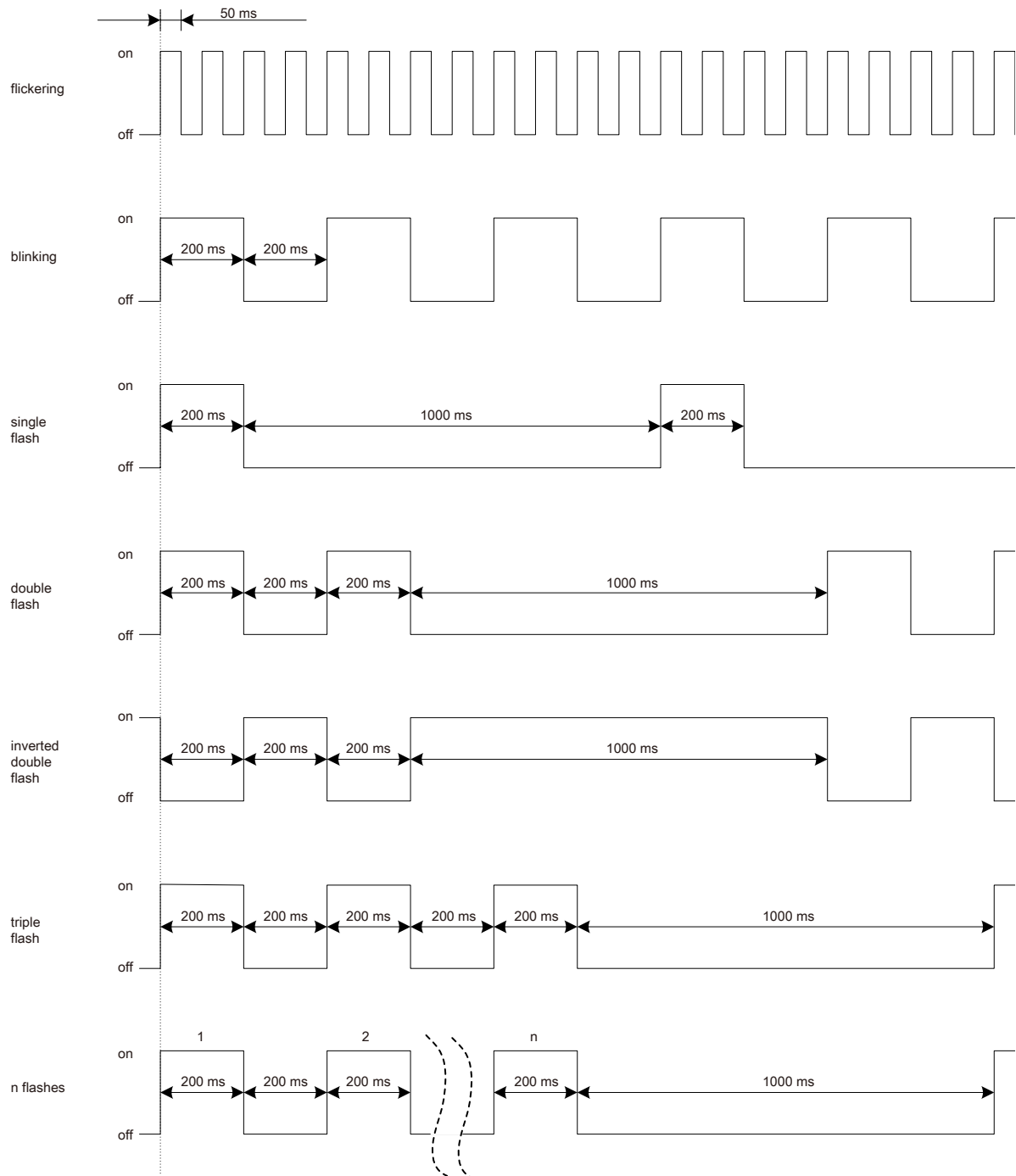

Figure 4.3 Meaning of LED Flash Rates

◆ Connecting the Option Card

■ Communication Connector

The Communication Option card is connected to the network using a RJ45 connector.

Table 4.1 Pin Assignment of RJ45 Communication Connector

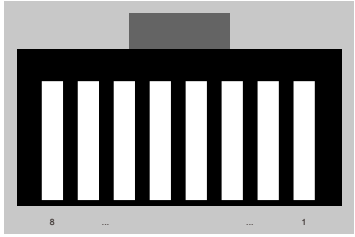
Connector	Pin	Signal	Description
	1	TD+	Send data
	2	TD-	Send data
	3	RD+	Receive data
	4	–	N.C. (Pins denoted as N.C. do not connect to any signal)
	5	–	N.C. (Pins denoted as N.C. do not connect to any signal)
	6	RD-	Receive data
	7	–	N.C. (Pins denoted as N.C. do not connect to any signal)
	8	–	N.C. (Pins denoted as N.C. do not connect to any signal)
	Housing	–	Shield

■ Communication Cable

YASKAWA recommends using EtherCAT® dedicated Cat5e or better communication cables.

■ Network Termination

If the drive is the last node in the network, network termination is automatically realized by the ASIC of the Communication Option card.

5 Mechanical & Electrical Installation

◆ Safety Precautions

⚠ DANGER *Electrical Shock Hazard. Do not examine, connect, or disconnect wiring on an energized drive. Before servicing, disconnect all power to the equipment and wait for the time specified on the warning label at a minimum. The internal capacitor stays charged after the drive is de-energized. The charge indicator LED extinguishes when the DC bus voltage decreases below 50 Vdc. When all indicators are OFF, remove the covers before measuring for dangerous voltages to make sure that the drive is safe. Failure to obey will cause death or serious injury.*

⚠ WARNING *Electrical Shock Hazard. Do not operate equipment when covers are missing. Some figures in this section include drives without covers or safety shields to more clearly show the inside of the drive. Replace covers and shields before operation. Use drives only as specified by the instructions. Failure to obey can cause death or serious injury.*

⚠ WARNING *Electrical Shock Hazard. Do not work on the drive or around the drive while wearing loose clothing or jewelry. Tighten loose clothing and remove all metal objects such as watches or rings. Failure to obey can cause death or serious injury.*

⚠ WARNING *Electrical Shock Hazard. Do not remove covers or touch circuit boards while the drive is energized. Failure to obey can cause death or serious injury.*

⚠ WARNING *Electrical Shock Hazard. Only let authorized persons install, wire, maintain, examine, replace parts, and repair the drive. Failure to obey can cause death or serious injury.*

⚠ WARNING *Electrical Shock Hazard. Do not make changes to the drive body or drive circuitry. Failure to obey can cause death or serious injury and will void warranty. Yaskawa is not responsible for changes to the product made by the user.*

⚠ WARNING *Fire Hazard. Tighten all terminal screws to the correct tightening torque. Connections that are too loose or too tight can cause incorrect operation and damage to the drive. Incorrect connections can also cause death or serious injury from fire.*

⚠ CAUTION *Crush Hazard. Do not hold the drive by the front cover or terminal cover. Tighten the screws correctly before moving the drive. Failure to obey can cause minor to moderate injury.*

NOTICE *Observe correct electrostatic discharge (ESD) procedures when touching the drive. Failure to obey can cause ESD damage to the drive circuitry.*

NOTICE *Do not lift the drive with the cover removed. Failure to obey can cause damage to the drive board and terminal block.*

NOTICE *Do not use unshielded wire for control wiring. Use shielded, twisted-pair wires and ground the shield to the ground terminal of the drive. Failure to obey can cause electrical interference and unsatisfactory system performance.*

NOTICE *Do not change the drive circuitry. Failure to obey can cause damage to the drive and will void warranty. Yaskawa is not responsible for modifications of the product made by the user.*

NOTICE *Make sure that all connections are correct after you install the drive and connecting peripheral devices. Failure to obey can cause damage to the drive.*

◆ Preconditions for Installing the Option Card

Prior to installing the Communication Option Card, wire the AC drive or regenerative unit and connect to the drive terminals. For more information on wiring and connecting the inverter drive or regenerative unit, refer to the manual packaged with the AC drive or regenerative unit.

Verify that the AC drive or regenerative unit runs normally without the option installed.

■ Tools Required

A Phillips screwdriver PH1(#1) or PH2(#2) is required to install the Communication Option card.

Note:

Tools required to prepare communication network cables for wiring are not listed in this manual.

◆ Installing the Option on a A1000, D1000, R1000 or U1000

1. Turn off the power. Wait until the CHARGE LED turns off and then remove the cover. Refer to the drive manual for direction on removing the front cover.
2. Plug the option card (E) to the CN5-A connector (C).
Fieldbus option cards must always be plugged into CN5-A connector.
3. Connect the ground wire (F) to option card and fix with screw (1).
Select shortest possible cable for ground connection.
4. Fix option card to the inverter with screw (2) additionally. Connect the ground wire (F) to inverter ground terminal (D).

Note:

There are only two screw holes on the drive for ground terminals. If three different option cards are connected, two of the ground wires will need to share the same ground terminal.

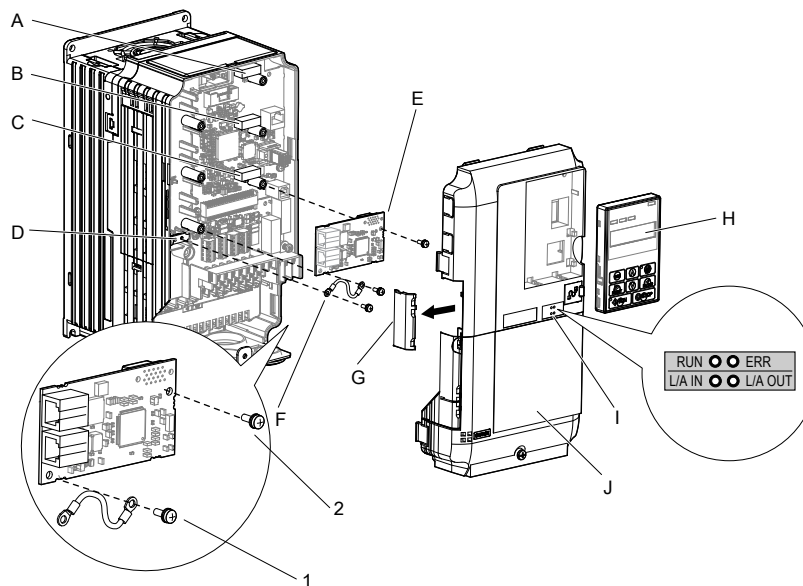

- | | |
|-----------------------------------|--|
| A - Connector CN5-C | F - Ground wire |
| B - Connector CN5-B | G - Opening for cable lines (use cutter to create the opening) |
| C - Connector CN5-A | H - Operator |
| D - Drive grounding terminal (FE) | I - LED labels |
| E - Option cards | J - Front cover |

Figure 5.1 Installing the Option Card on a A1000, D1000, R1000 or U1000

5. Prepare the RJ45 network cable connectors.
For inverter drives CIMR-Ax2A0004 to 0040 and 4A0002 to 0023: the network cable should be routed to the outside through the openings at the left side (G) of the front cover. Make sure no sharp edges remain.
For Inverter drives 2A0056 to 0211, and 4A0031 to 0165: enough space to keep all wiring inside the unit is available.

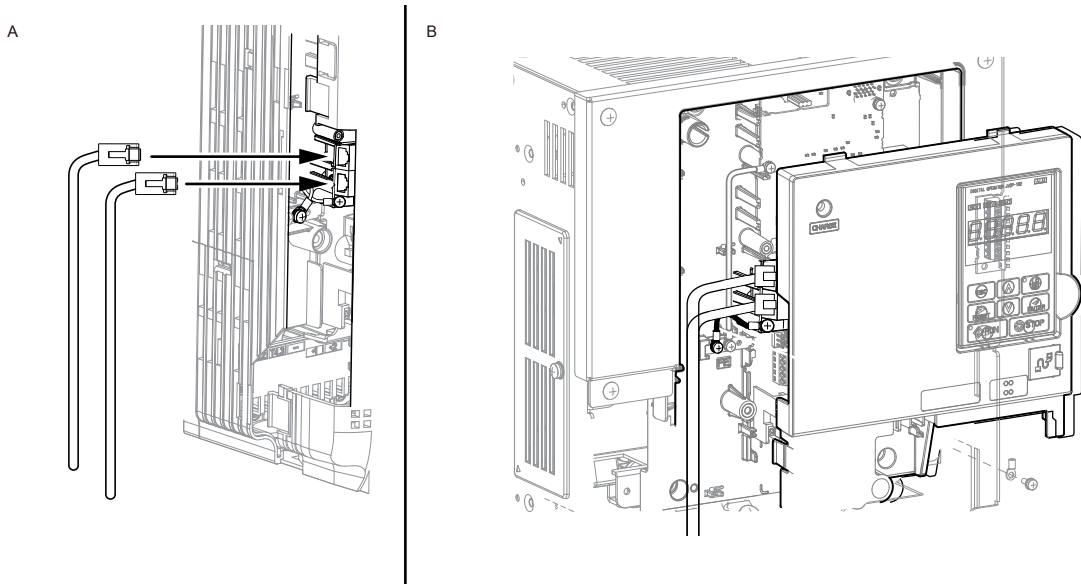

A - Opening for network cables
(CIMR-Ax2A0004 to 0040, 4A0002 to 0023)

B - Space for wiring (CIMR-Ao2A0056 to 0211, 4A0031 to 0165)

Figure 5.2 Network Cable Routing

6. Plug in the RJ45 network cable connector to the option.
7. Reinstall the front cover back onto the drive as it was before.
8. Attach the LED label (I) as shown in [Figure 5.1](#).
9. Switch on the drive power supply.

◆ Installing the Option on a V1000

1. Turn off the power. Wait until the CHARGE LED turns off and then remove the cover.
2. Remove the front cover. Refer to the drive manual for direction on removing the front cover.

Note:

The original front cover may be discarded because it will be replaced by the cover of the Communication Option card.

3. Remove the bottom cover and connect the Communication Option ground wire to the ground terminal.

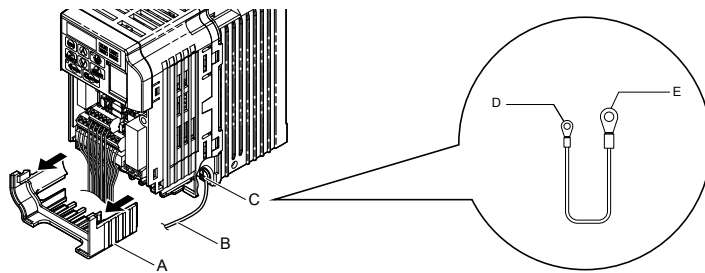

A - Bottom Cover
B - Ground Cable
C - Wire

D - Communication Option card connection (screw size: M3)
E - Drive-side connection (screw size: M3.5 to M6)

Figure 5.3 Connect Ground Wire

Select shortest possible cable for ground connection.

4. Re-attach the bottom cover.

5. Connect the Communication Option card to the drive. Properly secure the tabs on the left and right side of the Communication Option card to the drive case.

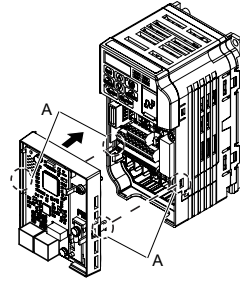

A - Tabs should line up

Figure 5.4 Attach Communication Option Card

6. Connect the ground wire to the Communication Option card.
When wiring the Communication Option card, pass the ground wire through the inside of the drive bottom cover, then pass the ground wire into the through-hole for the ground wire at the front of the Communication Option card.

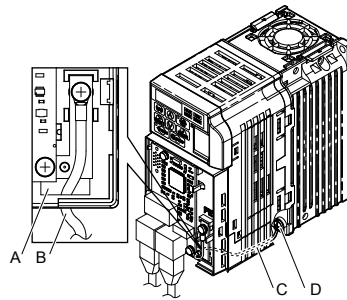

A - Through-hole for ground wire
B - Ground wire

C - Pass ground wire through the bottom cover of the drive
D - Drive ground terminal

Figure 5.5 Connect Ground Wire

7. Connect the communication wire to the Communication Option card modular connector.
8. Attach the cover to the front of the Communication Option card.
9. Switch on the drive power supply.

◆ Installing the Option on a GA700

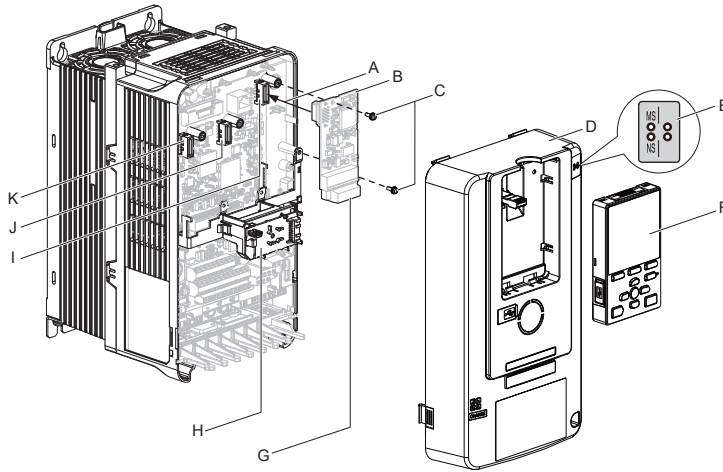

- | | |
|--|--|
| A - Insertion for CN5 connector | G - Option terminal block (CN1) |
| B - Option card | H - LED Status Ring board |
| C - Screws (included) | I - Connector CN5-A |
| D - Drive front cover | J - Connector CN5-B (Not for communication option installation) |
| E - LED label | K - Connector CN5-C (Not for communication option installation) |
| F - Keypad | |

Figure 5.6 GA700 Components with Option Card

The procedures for removing and re-attaching the front cover of the inverter drives, and for removing the LED Status Ring board, differ by model. For detailed information please refer to the Technical Manual of the inverter drive. Communication option cards can only be inserted into the **CN5-A** connector located on the drive control board.

1. Affix the LED label (E) in the appropriate position on the drive front cover (D).

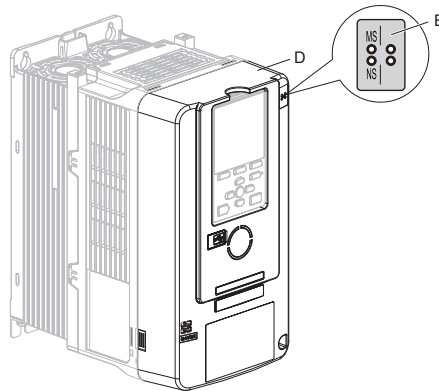

Figure 5.7 Affix the LED Label

2. Turn off the power. Wait until the CHARGE LED turns off and then remove the cover. Refer to the drive manual for direction on removing the front cover.

3. Move the keypad connector to the holder on the drive after removing the keypad and before removing the front cover. Insert the keypad connector tab into the holder when installing the keypad connector to the holder.

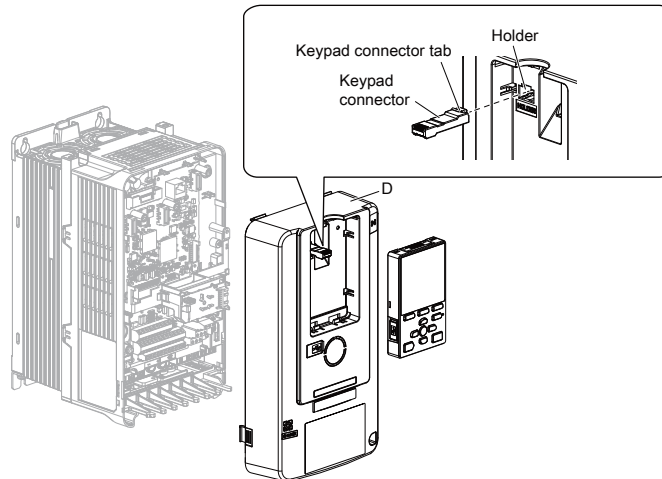

Figure 5.8 Remove the Front Cover and Keypad

4. Carefully remove the LED Status Ring board (H) and place it on the right side of the drive using the temporary placement holes. Do not remove the LED Status Ring board cable connector.

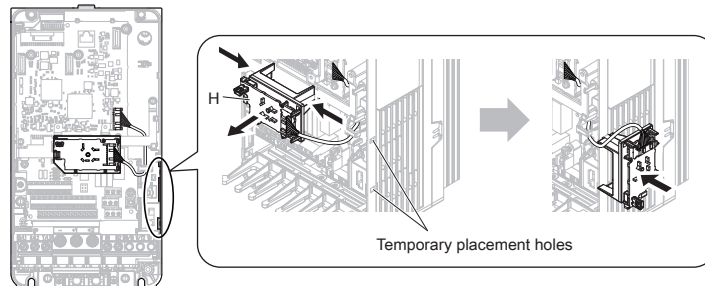

Figure 5.9 Remove the LED Status Ring Board

5. Insert the option card (B) into the CN5-A connector (I) on the drive and fasten it into place using the included screws (C). Tighten both screws to 0.5 to 0.6 Nm (4.4 to 5.3 in. lbs).

Note:

Installing the option card on a GA700 drive requires only two screws and does not require a ground wire. The option package ships with three screws and a ground wire for installation on other drive series. Do not use the ground wire or the extra screw.

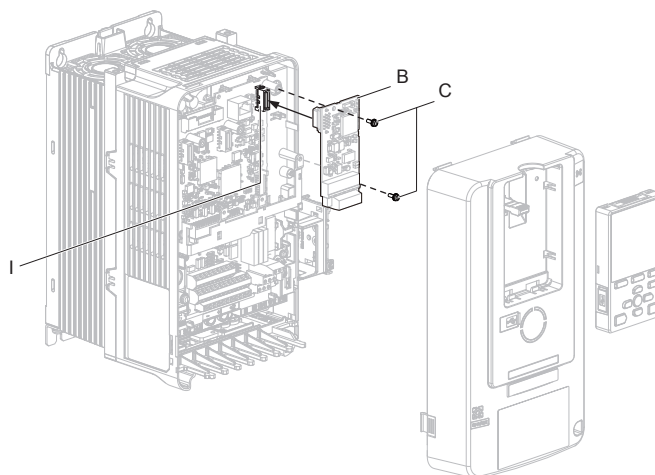

Figure 5.10 Insert the Option Card

6. Firmly connect the communication cable to option terminal block. Install communications cables apart from main-circuit wiring and other electrical and power lines. Ensure the cable end is firmly connected.
7. Reattach and secure the LED Status Ring board (H). Use the open space provided inside the LED Status Ring board to route option wiring. Do not pinch cables between the front cover or the LED Status Ring board and the drive.

8. Install the keypad to the drive after replacing the keypad connector and then the keypad connector. At that time, insert the keypad connector tab into the drive.
9. Reattach and secure the front cover of the drive (D) including the keypad (F).

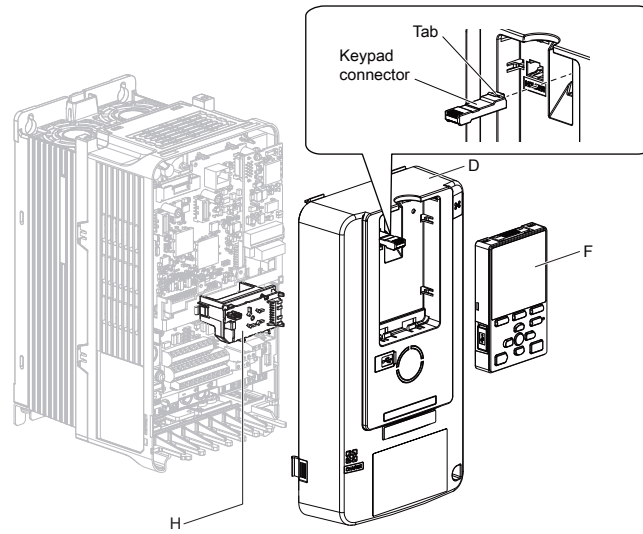
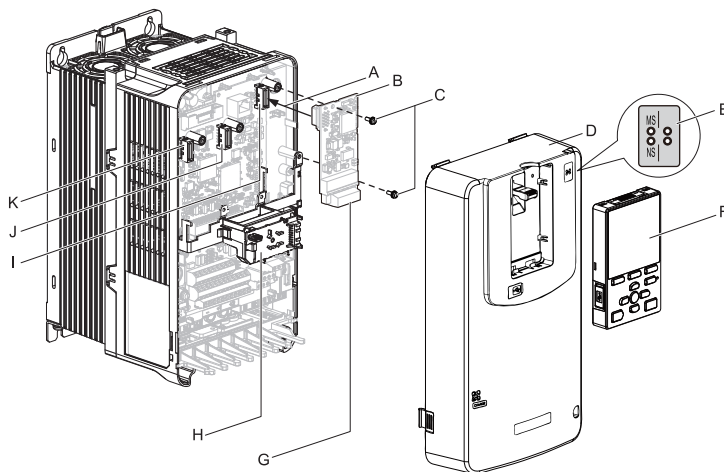

Figure 5.11 Reinstall the Front Cover and Keypad

10. Switch on the drive power supply.

◆ Installing the Option on a Q2A



- | | |
|--|--|
| A - Insertion for CN5 connector | G - Option terminal block (CN1) |
| B - Option card | H - USB port board |
| C - Screws (included) | I - Connector CN5-A |
| D - Drive front cover | J - Connector CN5-B (Not for communication option installation) |
| E - LED label | K - Connector CN5-C (Not for communication option installation) |
| F - Keypad | |

Figure 5.12 Q2A Components with Option Card

The procedures for removing and re-attaching the front cover of the inverter drives, and for removing the USB port board, differ by model. For detailed information please refer to the Technical Manual of the inverter drive. Communication option cards can only be inserted into the **CN5-A** connector located on the drive control board.

1. Affix the LED label (E) in the appropriate position on the drive front cover (D).

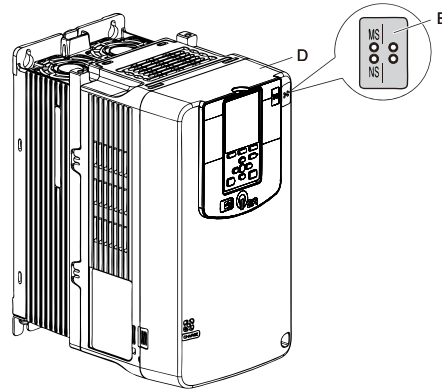

Figure 5.13 Affix the LED Label

2. Turn off the power. Wait until the CHARGE LED turns off and then remove the cover. Refer to the drive manual for direction on removing the front cover.
3. Move the keypad connector to the holder on the drive after removing the keypad and before removing the front cover. Insert the keypad connector tab into the holder when installing the keypad connector to the holder.

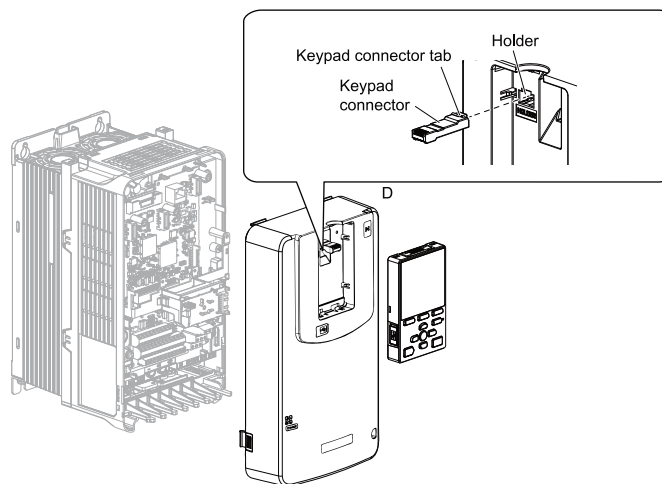

Figure 5.14 Remove the Front Cover and Keypad

4. Carefully remove the USB port board (H) and place it on the right side of the drive using the temporary placement holes. Do not remove the USB port board cable connector.

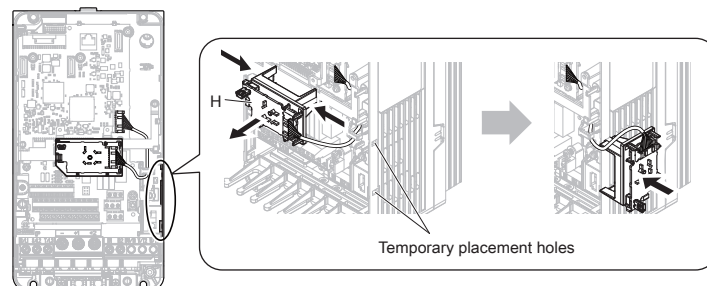

Figure 5.15 Remove the USB Port Board

5. Insert the option card (B) into the CN5-A connector (I) on the drive and fasten it into place using the included screws (C). Tighten both screws to 0.5 to 0.6 Nm (4.4 to 5.3 in. lbs).

Note:

Installing the option card on a Q2A drive requires only two screws and does not require a ground wire. The option package ships with three screws and a ground wire for installation on other drive series. Do not use the ground wire or the extra screw.

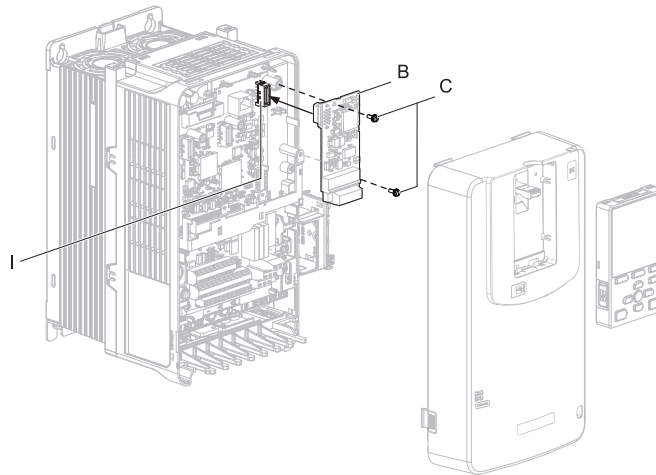

Figure 5.16 Insert the Option Card

6. Firmly connect the communication cable to option terminal block. Install communications cables apart from main-circuit wiring and other electrical and power lines. Ensure the cable end is firmly connected.
7. Reattach and secure the USB port board (H). Use the open space provided inside the USB port board to route option wiring. Do not pinch cables between the front cover or the USB port board and the drive.
8. Install the keypad to the drive after replacing the keypad connector and then the keypad connector. At that time, insert the keypad connector tab into the drive.
9. Reattach and secure the front cover of the drive (D) including the keypad (F).

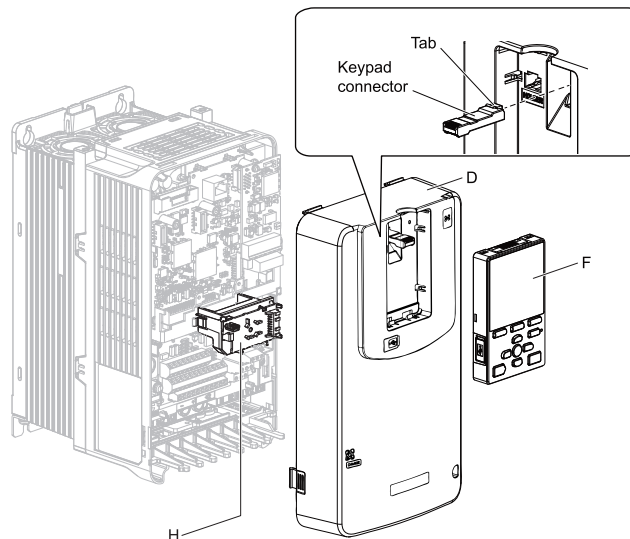

Figure 5.17 Reinstall the Front Cover and Keypad

10. Switch on the drive power supply.

◆ **ESI File**

For easy network implementation of drives equipped with a Communication Option card, the ESI file can be obtained from these sources:

- Europe:
<http://www.yaskawa.eu.com>
- Japan:
<http://www.e-mechatronics.com>
- USA:
<http://www.yaskawa.com>

Note:

For other areas, and when using Q2A AC drives, contact your sales representative.

6 EtherCAT Option Related Drive Parameters

◆ Parameters for A1000, D1000, R1000, U1000, GA700, V1000

Some drive parameters have influence on some functions of the communication option card. Check these parameters before starting network communications.

Table 6.1 Parameter Settings

No.	Name	Description	Default
b1-01 *1	Frequency Reference Selection	Selects the frequency reference input source 0: Operator - Digital preset speed d1-01 to d1-17 1: Terminals - Analog input terminals 2: MEMOBUS/Modbus communications 3: Option card 4: Pulse Input (Terminal RP)	*6
b1-02 *1	Run Command Selection	Selects the run command input source 0: Digital Operator - RUN and STOP keys 1: Digital input terminals Sx 2: MEMOBUS/Modbus communications 3: Option card	1
E2-04, E4-04, E5-04, E9-09 *2	Motor Poles	Set the number of motor poles described on the motor nameplate. Relevant for DSP402. 2 to 48	4
F6-01	Operation Selection after Communications Error	Determines drive response when a bUS error is detected during communications with the EtherCAT Option 0: Ramp to Stop 1: Coast to Stop 2: Fast-Stop 3: Alarm Only *3	1
F6-02	External Fault Detection Conditions (EF0)	Sets the condition for external fault detection (EF0) 0: Always detected 1: Detected only during operation	0
F6-03	Stopping Method for External Fault from Communication Option Board	Determines drive response for external fault input (EF0) detection during EtherCAT communication 0: Ramp to Stop 1: Coast to Stop 2: Fast-Stop 3: Alarm Only	1
F6-06 *4	Torque Reference/Torque Limit selection from Communications Option	0: Torque reference/torque limit via network communications are disabled. 1: Torque reference/torque limit via network communications are enabled. *5	0
F6-07	NetRef/ComRef Selection Function	0: Multi-step speed reference disabled 1: Multi-step speed reference allowed	0
F6-08	Reset Communication Related Parameters	Determines if communication-related parameters are set back to their original default values when the drive is initialized. 0: Do not reset F6-xx and F7-xx parameters when the drive is initialized using parameter A1-03. 1: Reset F6-xx and F7-xx parameters when the drive is initialized using parameter A1-03. Note: Setting this parameter does not affect communication-related parameters. Setting this parameter only determines if communication-related parameters (F6-xx and F7-xx) are also reset when A1-03 is used to initialize the drive.	0
o1-03 *7	Digital Operator Display Selection	Sets the units to display the frequency reference and output frequency. 0: 0.01 Hz 1: 0.01% (100% = E1-04) 2: r/min (enter the number of motor poles to E2-04/E4-04/E5-04). Relevant for DSP402. 3: User defined by parameters o1-10 and o1-11	*6

- *1 To start and stop the drive from an EtherCAT® master device using serial communications, set b1-02 to 3. To control the frequency reference of the drive via the master device, set b1-01 to 3.
- *2 It's necessary to set up the number of motor poles when the Drive Profile DSP402 objects are used. Also refer to *7
- *3 If set to 3, then the drive will continue to operate when an EF0 fault is detected. Take proper safety measures, such as installing an emergency stop switch.
- *4 This parameter might not appear in certain drives. Furthermore its availability is limited to depending on the control mode selection. For details refer to the technical manual for the drive the option card is used with.
- *5 If the drive is set to receive the torque reference/limit from the network (F6-06 = 1) make sure the value is set appropriately by the controller. If no torque reference/limit value is entered the motor will not produce torque.
- *6 The default value depends on the drive used and/or the drive software version. For details refer to the technical manual for the drive.

*7 Changing o1-03 changes the units for input object 2010 (Hex) (frequency reference), output object 2110 (Hex) (output frequency) and 2200 (Hex) (motor speed). Furthermore o1-03 must be set to 2 and the number of motor poles must be set to the correct value in order to use the Drive Profile DSP402.

◆ Parameters for Q2A

Some drive parameters have influence on some functions of the communication option card. Check these parameters before starting network communications.

Table 6.2 Parameter Settings

No.	Name	Description	Default
b1-01 *7	Freq. Ref. Sel. 1	Sets the input method for the frequency reference. 0: Keypad 1: Analog Input 2: Modbus 3: Option PCB 4: Pulse Train Input	*6
b1-02 *7	Run Comm. Sel 1	Sets the input method for the Run command. 0: Keypad 1: Analog Input 2: Modbus 3: Option PCB	1
E2-04, E4-04, E5-04, E9-09 *2	Motor Pole Count	Sets the number of motor poles. 2 to 48	4
F6-01	Comm.Error Selection	Sets the method to stop the motor or let the motor continue operating when the drive detects a bUS [Option Communication Error]. 0: Ramp->Stop 1: Coast->Stop 2: Fast-Stop (C1-09) 3: Alarm Only *3 4: AL-Run at d1-04 5: AL-Ramp Stop	1
F6-02	Comm Ext Flt Detect (EF0)	Sets when the drive will detect EF0 [Option Card External Fault] is detected. 0: Always Detected 1: Detect@RUN Only	0
F6-03	Comm Ext Flt Select (EF0)	Determines drive response for external fault input (EF0) detection during EtherCAT communication 0: Ramp->Stop 1: Coast->Stop 2: Fast-Stop (C1-09) 3: Alarm Only	1
F6-06 *4	Trq Ref/Lim Comms	Sets the function that enables and disables the torque reference and torque limit received from the communication option. 0: Disabled. 1: Enabled. *5	0
F6-07	Multi-Ref@NetRef/ComRef	Sets the function that enables and disables the multi-step speed reference when the frequency reference source is NetRef or ComRef (communication option card or Modbus communications). 0: Disable MultiStep References 1: Enable MultiStep References	0
F6-08	Comm Par RST@Initialize	Sets the function to initialize F6-xx and F7-xx parameters when the drive is initialized with A1-03 [Init Parameters]. 0: Retain Pars - No Reset 1: Factory Default - Reset	0
o1-03 *7	FrqDisplay Unit Selection	Sets the display units for the frequency reference and output frequency. 0: 0.01 Hz 1: 0.01% (100% = E1-04) 2: rpm (Enter the number of motor poles to E2-04/E4-04/E5-04). Relevant for DSP402. 3: User-selected units	*6

*1 To start and stop the drive from an EtherCAT® master device using serial communications, set b1-02 to 3. To control the frequency reference of the drive via the master device, set b1-01 to 3.

*2 E2-04 is necessary to set up when the Drive Profile DSP402 objects are used. Also refer to *7

*3 If set to 3, then the drive will continue to operate when an EF0 fault is detected. Take proper safety measures, such as installing an emergency stop switch.

*4 This parameter might not appear in certain drives. Furthermore its availability is limited to depending on the control mode selection. For details refer to the technical manual for the drive the option card is used with.

*5 If the drive is set to receive the torque reference/limit from the network (F6-06 = 1) make sure the value is set appropriately by the controller. If no torque reference/limit value is entered the motor will not produce torque.

- *6 The default value depends on the drive used and/or the drive software version. For details refer to the technical manual for the drive.
- *7 Changing o1-03 changes the units for input object 2010 (Hex) (frequency reference), output object 2110 (Hex) (output frequency) and 2200 (Hex) (motor speed). Furthermore o1-03 must be set to 2 and E2-04 must be set to the correct value in order to use the Drive Profile DSP402.

7 Troubleshooting

◆ Communication Option Card Error Codes

If a fault or alarm occurs in the inverter drive or regenerative unit, the fault or alarm will be stored in consecutive sub-indices of object 1003. Additionally an emergency telegram will be sent once.

Index (Hex)	Sub	Content	Acc.	PDO Map.	Data Type	Value (Range)
1003	0	Number of errors	RW	No	UNS8	00 (Hex) (00 - FF (Hex))
1003	1	Standard error field (Emergency error code)	RO	No	UNS32	0000 (Hex) (0000 - FFB8 (Hex))

Table 7.1 Emergency Telegram Specification

Byte	0	1	2	3	4	5	6	7
Content	Emergency Error Code			Error register object 1001 (Hex) = 1	Manufacturer specific error info. Not used. Set to zero.			

◆ Yaskawa-specific SDO Abort Codes

SDO abort codes are supported as specified in DS301. Additionally the abort codes listed below are implemented.

SDO Abort Code (Hex)	Description
0602 0010	Consecutive MEMOBUS/Modbus Read/Write/Enter commands are sent but the wait time between messages is too short.
	A MEMOBUS/Modbus Read or Write Response (2140 (Hex) and 2150 (Hex)) was attempted but no or an incorrect MEMOBUS/Modbus address has been written to object 2040 (Hex) or 2050 (Hex) before.
	A MEMOBUS/Modbus write request has been sent during DC bus under voltage.
0602 0022	Drive Profile DSP402 is used and a value is written to object 6042 (Hex) (v1 Target Velocity) while the drive status is not "Operation Enable".
	Object 2155 (Hex) is tried to be read while the SI-ES3 option is not in "Operational" state.
	A MEMOBUS/Modbus Read or Write command (2040 (Hex) and 2050 (Hex)) was performed with an invalid MEMOBUS/Modbus address.

◆ Faults

This section gives information about the causes and possible solutions of faults. You must use the Fault Reset operation to remove the fault before you can operate the drive. Use the information in this table to remove the cause of the fault.

Code	Name	Causes	Possible Solutions
bUS	Option Communication Error	The drive did not receive a signal from the controller.	Correct wiring errors.
		The communications cable wiring is incorrect.	
		There is a short-circuit in the communications cable or the communications cable is not connected.	<ul style="list-style-type: none"> Repair short circuits and connect cables. Replace the defective communications cable.
		Electrical interference caused a communication data error.	<ul style="list-style-type: none"> Examine the control circuit lines, main circuit lines, and ground wiring, and decrease the effects of electrical interference. Make sure that a magnetic contactor is not the source of the electrical interference, then use a Surge Protective Device if necessary. Use only the recommended cables or other shielded line. Ground the shield on the controller side or the drive input power side. Separate the communication wiring from drive power lines, and install a noise filter to the input side of the power supply for communication. Decrease the effects of electrical interference from the controller.

7 Troubleshooting

Code	Name	Causes	Possible Solutions
		The option is incorrectly installed to the drive.	Correctly install the option to the drive.
		The option is damaged.	If the fault continues and the wiring is correct, replace the option.
EF0	Option Card External Fault	The communication option received an external fault from the controller.	<ol style="list-style-type: none"> Find the device that caused the external fault and remove the cause. Clear the external fault input from the controller.
		A programming error occurred on the controller side.	Examine the operation of the controller program.
oFA00	Option Not Compatible with Port	The option card connected to connector CN5-A is not compatible.	Connect the option card to the correct connector. Note: Encoder option cards are not compatible with connector CN5-A.
oFA01	Option Fault/Connection Error	The option card connected to connector CN5-A is not compatible.	<ol style="list-style-type: none"> De-energize the drive. Refer to the option card manual and correctly connect the option card to the connector on the drive.
oFA30 to oFA43	Communication Option Card Connection Error (CN5-A)	A fault occurred in the option card.	<ol style="list-style-type: none"> De-energize the drive. Make sure that the option card is correctly connected to the connector. If the problem continues, replace the option card.
oFb00	Option Not Compatible with Port	The option card connected to connector CN5-B is not compatible.	Connect the option card to the correct connector. Note: DO-A3, AO-A3, PG-B3, and PG-X3 options can connect to connector CN5-B. Use connector CN5-C when connecting only one encoder option card.
oFb02	Duplicate Options	The same option cards or the same type of option cards are connected to connectors CN5-A, B, and C.	Connect the option card to the correct connector.
oFC00	Option Not Compatible with Port	The option card connected to connector CN5-C is not compatible.	Connect the option card to the correct connector. Note: AI-A3, DI-A3, and communication option cards cannot be connected to the CN5-C connector.
oFC02	Duplicate Options	The same option cards or the same type of option cards are connected to connectors CN5-A, B, and C.	Connect the option card to the correct connector.

◆ Minor Faults/Alarms

This section gives information about the causes and possible solutions when a minor fault or alarm occurs. Use the information in this table to remove the cause of the minor fault or alarm.

Code	Name	Causes	Possible Solutions
CALL	Serial Comm Transmission Error	The communications cable wiring is incorrect.	Correct any wiring errors.
		There is a short circuit or the communications cable is not connected.	<ul style="list-style-type: none"> Repair short circuits and connect cables. Replace the defective communications cable.
		There was a programming error on the controller side.	Examine communications at start-up and correct programming errors.
		The communications circuitry is damaged.	<ul style="list-style-type: none"> Do a self-diagnostics check. If the problem continues, replace the control board or the drive. For information about replacing the control board, contact Yaskawa or your nearest sales representative.
		The termination resistor setting for MEMOBUS/Modbus communications is incorrect.	On the last drive in a MEMOBUS/Modbus network, set DIP switch S2 to the ON position to enable the termination resistor.
EEP	EEPROM Checksum Error	Communication wiring is faulty, there is a short circuit, or something is not connected properly.	Correct any wiring errors.
		EEPROM checksum error.	<ul style="list-style-type: none"> If these errors occur, the object dictionary will be reset to its default values. After the object dictionary has been changed and object dictionary contents are then changed, execute a Store Parameter command (Index = 1010 (Hex)). If the object dictionary has not been changed, execute a Restore Parameter command (Index = 1011 (Hex)).
		Programming error occurred on the controller side.	Check communications at start-up and correct programming errors.
		Communications circuitry is damaged.	<ul style="list-style-type: none"> Perform a self-diagnostics check. If the problem continues, replace either the control board or the entire drive. For instructions on replacing the control board, contact Yaskawa or your nearest sales representative.
		Termination resistor setting for MEMOBUS/Modbus communications is incorrect.	Enable the termination resistor in the last drive in a MEMOBUS/Modbus network by setting DIP switch S2 to the ON position.

8 Specifications

Item	Specification
Model	SI-ES3 For V1000: SI-ES3/V
Communication Profile	DSP 301 Ver. 4.02 DSP 402 Ver. 1.1 Velocity Mode
Connector	RJ45 connector
Communication Speed	10/100 Mbps
Ambient Temperature	-10 °C to +50 °C
Humidity	up to 95% RH (non-condensing)
Storage Temperature	-20 °C to +60 °C (allowed for short-term transport of the product)
Area of Use	Indoor (free of corrosive gas, airborne particles, etc.)
Altitude	Up to 1000 m

9 Glossary

Representations Used in This Manual	Description
EtherCAT® Option	Yaskawa EtherCAT® communication option card
EtherCAT®	Ethernet for Control Automation Technology, an open Ethernet-based network
Online-DRV	NOID processing mode, process (ctrl/resp) data is active
Online-DRVMB	NOID processing mode, process resp data is active, ctrl data is on hold (Until MEMOBUS process is complete)
Online-PRG	NOID processing mode, NO process (ctrl/resp) data is active
Host	YASKAWA AC drive or regenerative unit
LED	Light Emitting Diode
OPT, Option	The unit described in this document
INV, Inverter, AC drive	AC drive or regenerative unit
PCB	Printed Circuit Board
FCS	Frame Check Sequence
INVR	MEMOBUS register number
ESI	EtherCAT® Slave Information file

Index

A	
Alarm	24
B	
bUS	
Fault	23
C	
CALL	24
E	
EEP	24
EFO	
Fault	24
F	
Fault	23
M	
Minor Fault	24
O	
oFA00	24
oFA01	24
oFA30 to oFA43	24
oFb00	24
oFb02	24
oFC00	24
oFC02	24

Revision History

Date of Publication	Revision Number	Section	Revised Content
August 2018	-	-	First Edition Contains information for A/V1000, D/R/U1000, GA700, and Q2A.

EtherCAT Option

Installation Manual

YASKAWA EUROPE GmbH

Hauptstraße 185, 65760 Eschborn, Germany
Phone: +49-6196-569-500 Fax: +49-6196-569-398
E-mail: support@yaskawa.eu.com
<http://www.yaskawa.eu.com>

DRIVE CENTER (INVERTER PLANT)

2-13-1, Nishimiyaichi, Yukuhashi, Fukuoka, 824-8511, Japan
Phone: +81-930-25-2548 Fax: +81-930-25-3431
<http://www.yaskawa.co.jp>

YASKAWA AMERICA, INC.

2121, Norman Drive South, Waukegan, IL 60085, U.S.A.
Phone: +1-800-YASKAWA (927-5292) or +1-847-887-7000 Fax: +1-847-887-7310
<http://www.yaskawa.com>

In the event that the end user of this product is to be the military and said product is to be employed in any weapons systems or the manufacture thereof, the export will fall under the relevant regulations as stipulated in the Foreign Exchange and Foreign Trade Regulations. Therefore, be sure to follow all procedures and submit all relevant documentation according to any and all rules, regulations and laws that may apply. Specifications are subject to change without notice for ongoing product modifications and improvements.

Original instructions.

© 2018 YASKAWA Europe GmbH

YASKAWA Europe GmbH



TOEPYEUOEC101

TOEPYEUOEC101
Revision: A <0>-0
September 2018
Published in Germany
11-9

YASKAWA