

YASKAWA AC Drive Option **MECHATROLINK-III** Technical Manual

Type: SI-ET3

To properly use the product, read this manual thoroughly and retain for easy reference, inspection, and maintenance. Ensure the end user receives this manual.

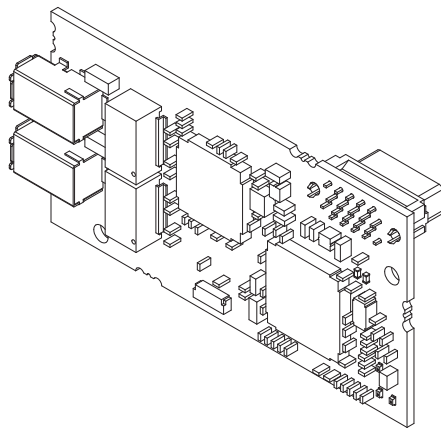

Copyright © 2016 YASKAWA ELECTRIC CORPORATION

All rights reserved. No part of this publication may be reproduced, stored in a retrieval system, or transmitted, in any form or by any means, mechanical, electronic, photocopying, recording, or otherwise, without the prior written permission of Yaskawa. No patent liability is assumed with respect to the use of the information contained herein. Moreover, because Yaskawa is constantly striving to improve its high-quality products, the information contained in this manual is subject to change without notice. Every precaution has been taken in the preparation of this manual. Yaskawa assumes no responsibility for errors or omissions. Neither is any liability assumed for damages resulting from the use of the information contained in this publication.

Table of Contents

1	PREFACE AND SAFETY	4
2	OVERVIEW	7
3	RECEIVING	9
4	OPTION COMPONENTS	10
5	INSTALLATION PROCEDURE	12
6	RELATED DRIVE PARAMETERS	24
7	TRANSMISSION INTERFACE	26
8	MECHATROLINK-III COMMANDS	31
9	MAIN COMMAND	33
10	SUB-COMMANDS	47
11	TROUBLESHOOTING	52
12	EUROPEAN STANDARDS	55
13	SPECIFICATIONS	57
14	DISPOSAL	58

1 Preface and Safety

YASKAWA Electric supplies component parts for use in a wide variety of industrial applications. The selection and application of YASKAWA products remain the responsibility of the equipment designer or end user. YASKAWA accepts no responsibility for the way its products are incorporated into the final system design. Under no circumstances should any YASKAWA product be incorporated into any product or design as the exclusive or sole safety control. Without exception, all controls should be designed to detect faults dynamically and fail safely under all circumstances. All products designed to incorporate a component part manufactured by YASKAWA must be supplied to the end user with appropriate warnings and instructions as to the safe use and operation of that part. Any warnings provided by YASKAWA must be promptly provided to the end user. YASKAWA offers an express warranty only as to the quality of its products in conforming to standards and specifications published in the manual. **NO OTHER WARRANTY, EXPRESS OR IMPLIED, IS OFFERED.** YASKAWA assumes no liability for any personal injury, property damage, losses, or claims arising from misapplication of its products.

◆ Applicable Documentation

The following manuals are available for the SI-ET3 option:

SI-ET3 Option

YASKAWA AC Drive Option SI-ET3 MECHATROLINK-III Installation Manual Manual No: TOBP C730600 88	This guide is packaged together with the product and contains information necessary to install the option and set related drive parameters.
YASKAWA AC Drive Option SI-ET3 MECHATROLINK-III Technical Manual Manual No: SIEP C730600 88 (This book)	The technical manual contains detailed information about the option. Access the following sites to obtain the technical manual: U.S.: http://www.yaskawa.com Europe: http://www.yaskawa.eu.com Japan: http://www.e-mechatronics.com Other areas: Check the back cover of these manuals. For questions, contact Yaskawa or a Yaskawa representative.

Drive

YASKAWA AC Drive Manuals	Drive manuals contain basic installation and wiring information in addition to detailed parameter setting, fault diagnostic, and maintenance information. The most recent versions of these manuals are available for download on our documentation websites: U.S.: http://www.yaskawa.com Europe: http://www.yaskawa.eu.com Japan: http://www.e-mechatronics.com Other areas: Check the back cover of these manuals. For questions, contact Yaskawa or a Yaskawa representative.
-------------------------------------	---

◆ Terms

- Note:** Indicates supplemental information that is not related to safety messages.
- Option:** YASKAWA AC Drive Option MECHATROLINK-III
- Drive:**
- YASKAWA AC Drive 1000-Series (A1000, U1000, Z1000U)
 - YASKAWA AC Drive GA500
 - YASKAWA AC Drive GA700
 - YASKAWA AC Drive GA800
 - YASKAWA AC Drive CR700
 - YASKAWA AC Drive CH700
- Keypad:**
- LCD Operator for YASKAWA AC Drive 1000-Series
 - LED Operator for YASKAWA AC Drive 1000-Series
 - LCD Keypad for YASKAWA AC Drive GA500, GA700, GA800, CR700, and CH700
 - LED Keypad for YASKAWA AC Drive GA500, GA700, GA800, CR700, and CH700

◆ Registered Trademarks

- MECHATROLINK-III is a trademark of the MECHATROLINK Members Association (MMA).
 - All trademarks are the property of their respective owners.
-

◆ Supplemental Safety Information

Read and understand this manual before installing, operating, or servicing this option. The option must be installed according to this manual and local codes.

The following conventions are used to indicate safety messages in this manual. Failure to heed these messages could result in serious or possibly even fatal injury or damage to the products or to related equipment and systems.

DANGER

Indicates a hazardous situation, which, if not avoided, will cause death or serious injury.

WARNING

Indicates a hazardous situation, which, if not avoided, could cause death or serious injury.

CAUTION

Indicates a hazardous situation, which, if not avoided, could cause minor or moderate injury.

NOTICE

Indicates an equipment damage message.

■ General Safety

General Precautions

- The diagrams in this section may include options and drives without covers or safety shields to illustrate details. Be sure to reinstall covers or shields before operating any devices. The option should be used according to the instructions described in this manual.
- The diagrams in this manual are provided as examples only and may not pertain to all products covered by this manual.
- The products and specifications described in this manual or the content and presentation of the manual may be changed without notice to improve the product and/or the manual.
- Contact Yaskawa or a Yaskawa representative and provide the manual number shown on the front cover to order new copies of the manual.

DANGER

Heed the safety messages in this manual.

Failure to comply will cause death or serious injury.

The operating company is responsible for any injuries or equipment damage resulting from failure to heed the warnings in this manual.

WARNING

Electrical Shock Hazard

Do not modify the drive or option circuitry.

Modifications to circuitry can cause serious injury or death, will cause damage to the drive and option, and will void the warranty. Yaskawa is not responsible for modifications of the product made by the user.

NOTICE

Do not use steam or other disinfectants to fumigate wood for packaging the drive or option. Use alternative methods, for example heat treatment, before you package the components.

Gas from wood packaging fumigated with halogen disinfectants, for example fluorine, chlorine, bromine, iodine or DOP gas (phthalic acid ester), can cause damage to the drive and option.

2 Overview

The option provides a communications connection between the drive and a MECHATROLINK-III network. The option connects the drive to a MECHATROLINK-III network and facilitates the exchange of data.

This manual explains the handling, installation and specifications of this product.

MECHATROLINK-III is a communications link to connect industrial devices (such as smart motor controllers, operator interfaces, and variable frequency drives) as well as control devices (such as programmable controllers and computers) to a network. MECHATROLINK-III is a simple, networking solution that reduces the cost and time to wire and install factory automation devices, while providing interchangeability of like components from multiple vendors.

Install the option/MIII option on a drive to perform the following functions from a MECHATROLINK-III master device:

- Operate the drive
- Monitor the drive operation status
- Change drive parameter settings

◆ Compatible Products

The option can be used with the products in [Table 1](#).

Table 1 Compatible Products

Product Series	Model(s)	Software Version <1>
A1000	CIMR-A□2A□□□□	≥1020
	CIMR-A□4A0002 to 4A0675	≥1020
	CIMR-A□4A0930 and 4A1200	≥3015
	CIMR-A□5A□□□□	≥5040 ≥1020
U1000	CIMR-U□□A□□□□	≥1010
	CIMR-U□□E□□□□	
	CIMR-U□□P□□□□	
	CIMR-U□□W□□□□	
Z1000U	CIMR-Z□□A□□□□	≥6110
	CIMR-Z□□E□□□□	
	CIMR-Z□□P□□□□	
	CIMR-Z□□W□□□□	
GA500 <2>	CIPR-GA50□□□□□	≥1010
GA700 <2>	CIPR-GA70□□□□□	≥1010
GA800 <2>	CIPR-GA80□□□□□	≥9010
CR700 <2>	CIPR-CR70□□□□□	≥1012
CH700 <2>	CIPR-CH70□□□□□	≥1012

<1> Refer to “PRG” on the drive nameplate for the software version number.

<2> Before you install the option on a YASKAWA AC Drive GA500, GA700, GA800, CR700, or CH700, make sure that the option software version is PRG: 6202 or later.

Note: Refer to the option package labeling in the field designated “PRG” (four digit number)” or the option labeling in the field designated “C/N” (S + four digit number)” to identify the option software version.

◆ Install the Option on a GA500 Drive

An option card installation case is necessary to install the option on a GA500 drive. The option card installation case model is: JOHB-GA500. This case is sold separately. Refer to the option card installation case manual for more information about installation.

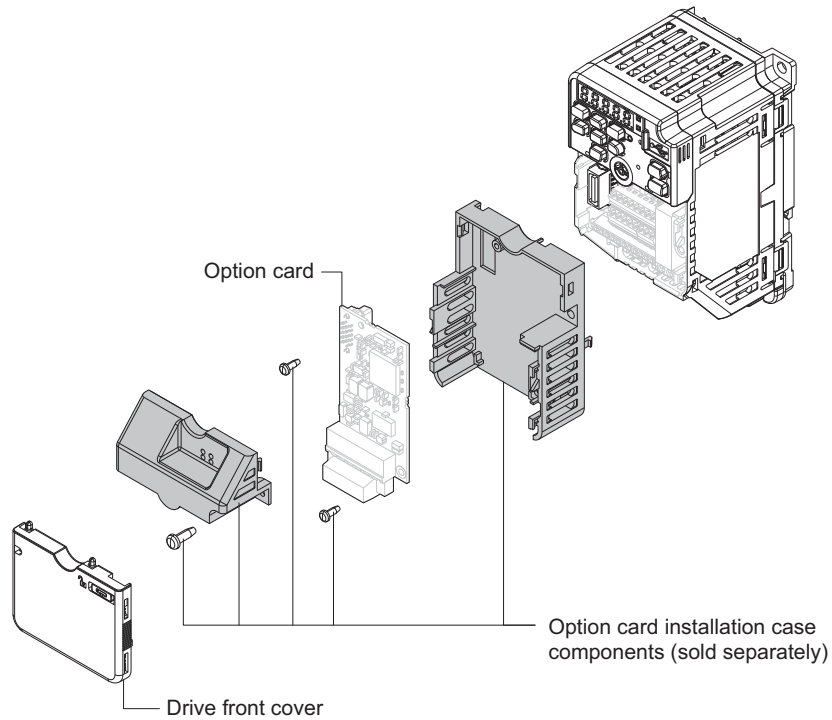

Figure 1 Option Card Installation Case

3 Receiving

After receiving the option package:





1. Make sure that the option is not damaged and no parts are missing. Contact your sales outlet if the option or other parts appear damaged.

NOTICE: Do not use damaged parts to connect the drive and the option. Failure to comply could damage the drive and option.

2. Confirm that the model number on the option nameplate and the model listed in the purchase order are the same. Refer to **Figure 2** on page **10** for details. Contact the distributor where the option was purchased or contact Yaskawa or a Yaskawa representative about any problems with the option.

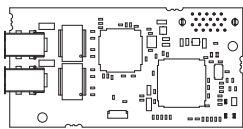
◆ Option Package Components

Table 2 Option Package Contents

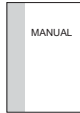
Description:	Option	Ground Wire <1>	Screws (M3)	LED Labels		Installation Manual
				1000-Series	GA500, GA700, GA800, CR700, and CH700	
						
Quantity:	1	1	3 <2>	1	1	1

<1> GA700, GA800, CR700, and CH700 drives do not use the ground wire.

<2> GA700, GA800, CR700, and CH700 drives use two screws only.

◆ Installation Tools

- A Phillips screwdriver. Phillips screw sizes vary by drive capacity.
- A flat-blade screwdriver (blade depth: 0.4 mm (0.02 in), width: 2.5 mm (0.1 in)).
- A pair of diagonal cutting pliers.
- A small file or medium-grit sandpaper.

4 Option Components

◆ MECHATROLINK-III Option

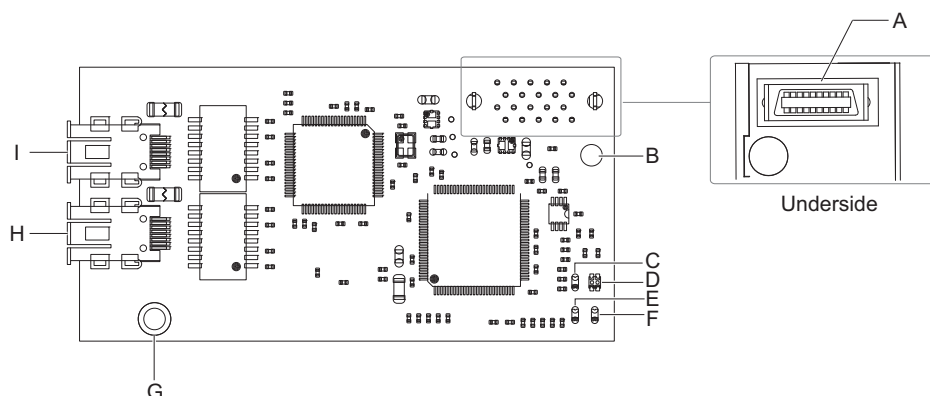

- A – Connector (CN5)**
- B – Installation hole**
- C – LED (CON) <1>**
- D – LED (R/E) <1>**
- E – LED (LK2) <1>**
- F – LED (LK1) <1>**
- G – Ground terminal (FE) and installation hole <2>**
- H – Communication connector CN1**
- I – Communication connector CN2**

<1> Refer to *Option LED Display on page 11* for details on the LEDs

<2> Connect the provided ground wire during installation. Installation on GA700, GA800, CR700, and CH700 drives does not require the ground wire.

Figure 2 SI-EN3 Option Components

◆ Connector

Table 3 Communication Connector

MECHATROLINK-III Connector	Pin No.	Signal Name	I/O	Function
	1	TXD_P	I/O	Send data (+): OUT
	2	TXD_N	I/O	Send data (-): OUT
	3	RXD_P	I/O	Receive data (-): IN
	4	(NC)	–	–
	5	(NC)	–	–
	6	RXD_N	I/O	Receive data (-): IN
	7	(NC)	–	–
	8	(NC)	–	–
	Shell	SLD	–	Shield

◆ Option LED Display

The MECHATROLINK-III Option has four LEDs that indicate the option card or communication status.

■ Defining Option LED States

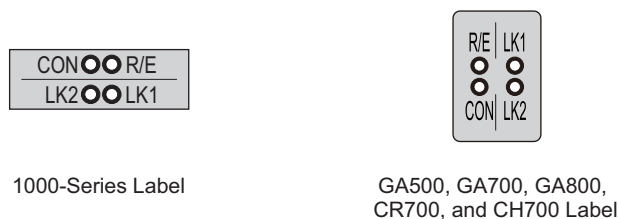

1000-Series Label

GA500, GA700, GA800,
CR700, and CH700 Label

Figure 3 Option LED Labels

Table 4 Option LED States

Name	State	Operating Status	Description
R/E	Lit in green	Power supply on	<ul style="list-style-type: none"> SI-ET3 has been successfully powered up An internal, self-diagnostic check completed in the SI-ET3
	Lit in red	Error	<ul style="list-style-type: none"> Error/alarm occurred Command error occurred (parameter error, phase error, combination error)
	Flashing in red	SI-ET3 error	Error found during the SI-ET3 self-diagnostic check
	Unlit	Power supply off	<ul style="list-style-type: none"> The drive has no power SI-ET3 is not properly connected to the drive, or SI-ET3 has no power An internal, self-diagnostic error occurred in the SI-ET3
CON	Lit in green	Connection established	Established connection
	Unlit	Connection unestablished	Connection with master device is not established
LK1	Lit in green	Connector CN1 connected	Connector CN1 is connected to other stations
	Unlit	Connector CN1 disconnected	Connector CN1 is not connected to other stations (cable not connected, cable disconnected, other stations not powered up)
LK2	Lit in green	Connector CN2 connected	Connector CN2 is connected to other stations
	Unlit	Connector CN2 disconnected	Connector CN2 is not connected to other stations (cable not connected, cable disconnected, other stations not powered up)

5 Installation Procedure

◆ Section Safety

DANGER

Electrical Shock Hazard

Do not inspect, connect, or disconnect any wiring while the drive is energized.

Failure to comply will cause death or serious injury.

Before servicing, disconnect all power to the equipment and wait for at least the time specified on the warning label. The internal capacitor remains charged even after the drive is de-energized. The charge indicator LED will extinguish when the DC bus voltage is below 50 Vdc. When all indicators are OFF, measure for unsafe voltages to confirm the drive is safe.

WARNING

Electrical Shock Hazard

Do not operate equipment with covers removed.

Failure to comply could cause death or serious injury.

The diagrams in this section may include options and drives without covers or safety shields to illustrate details. Reinstall covers and shields before operating the drive and run the drive according to the instructions described in this manual.

Do not allow unqualified personnel to perform work on the drive or option.

Failure to comply could cause death or serious injury.

Only authorized personnel familiar with installation, adjustment, and maintenance of AC drives and options may perform work.

Do not remove covers or touch circuit boards while the drive is energized.

Failure to comply could cause death or serious injury.

Do not use damaged wires, stress the wiring, or damage the wire insulation.

Failure to comply could cause death or serious injury.

Fire Hazard

Tighten all terminal screws to the specified tightening torque.

Loose or overtightened connections could cause erroneous operation and damage to the terminal block or start a fire and cause death or serious injury.

NOTICE

Damage to Equipment

Observe proper electrostatic discharge (ESD) procedures when handling the option, drive, and circuit boards.

Failure to comply could cause ESD damage to circuitry.

Never connect or disconnect the motor from the drive while the drive is outputting voltage.

Improper equipment sequencing could damage the drive.

Do not connect or operate any equipment with visible damage or missing parts.

Failure to comply could further damage the equipment.

Do not use unshielded wire for control wiring.

Failure to comply may cause electrical interference resulting in poor system performance. Use shielded, twisted-pair wires and ground the shield to the ground terminal of the drive.

NOTICE

Properly connect all pins and connectors on the option and drive.

Failure to comply could prevent proper operation and damage equipment.

Confirm that all connections are correct after installing the option and connecting peripheral devices.

Failure to comply could damage the option.

◆ Procedures for Installing and Wiring Options on a Drive

Procedures to install and wire the option are different for different drive models.

Refer to [Table 5](#) to check the procedures to install and wire the option on a drive.

Table 5 Procedures for Installing and Wiring Options on a Drive

Product Series	Procedures for Installing and Wiring Options on a Drive	Page
A1000	Procedure A	14
U1000	Procedure A	14
Z1000U	Procedure A	14
GA500	<1> <2>	–
GA700	Procedure B	18
GA800	Procedure B	18
CR700	Procedure B	18
CH700	Procedure B	18

<1> Use the option card installation case manual to install the option on GA500 drives.

<2> Before you install the option on a YASKAWA AC Drive GA500, make sure that the option software version is PRG: 6202 or later.

■ Procedure A

This section shows the procedure to install and wire the option on a 1000-series drive.

Prepare the Drive for the Option

1. Correctly wire the drive as specified by the manual packaged with the drive.
2. Make sure that the drive functions correctly.

Refer to [Figure 4](#) for an exploded view of the drive with the option and related components for reference in the installation procedure.

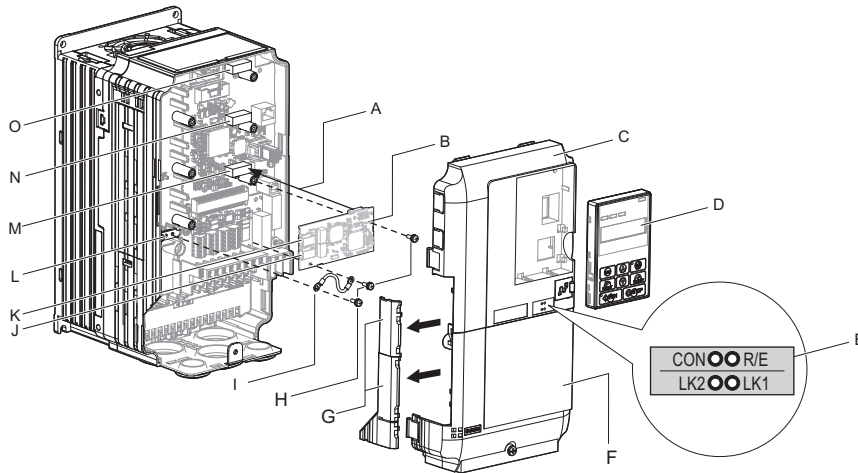

- | | |
|--|--|
| A – Insertion point for CN5 connector | K – Option modular connector CN2 |
| B – SI-ET3 option | L – Drive grounding terminal (FE) |
| C – Drive front cover | M – Connector CN5-A |
| D – Keypad | N – Connector CN5-B
(Not available for communication option installation.) |
| E – LED label | O – Connector CN5-C
(Not available for communication option installation.) |
| F – Drive terminal cover | |
| G – Removable tabs for wire routing | |
| H – Included screws | |
| I – Ground wire | |
| J – Option modular connector CN1 | |

Figure 4 Drive Components with Option

Install the Option

Remove the front covers of the drive before you install the option. Refer to the drive manual for information about how to remove the front covers. Different drive sizes have different cover removal procedures. You can only install this option into the CN5-A connector on the drive control board.

DANGER! Electrical Shock Hazard. Do not inspect, connect, or disconnect any wiring while the drive is energized. Failure to comply will cause death or serious injury. Before servicing, disconnect all power to the equipment and wait for at least the time specified on the warning label. The internal capacitor remains charged even after the drive is de-energized. The charge indicator LED will extinguish when the DC bus voltage is below 50 Vdc. When all indicators are OFF, measure for unsafe voltages to confirm the drive is safe.

1. Shut off power to the drive, wait the appropriate amount of time for voltage to dissipate, then remove the keypad (D) and front covers (C, F).

Refer to the manual packaged with the drive for details on keypad and cover removal.

NOTICE: Damage to Equipment. Observe proper electrostatic discharge (ESD) procedures when handling the option, drive, and circuit boards. Failure to comply could cause ESD damage to circuitry.

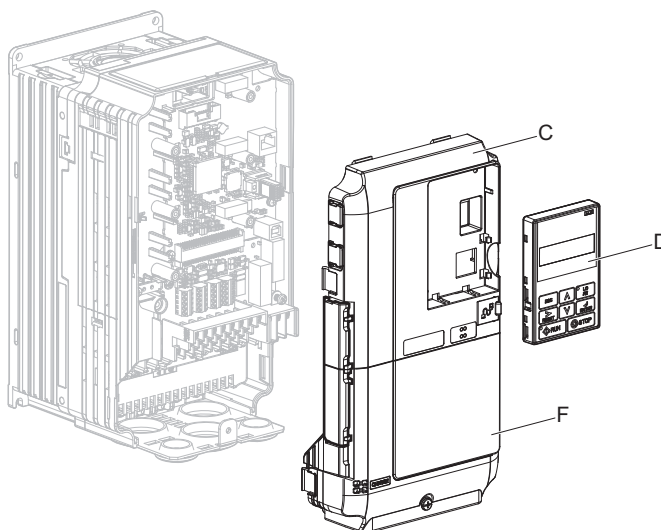

Figure 5 Remove the Keypad, Front Cover, and Terminal Cover

2. Affix the LED label (E) in the appropriate position on the drive front cover (C).

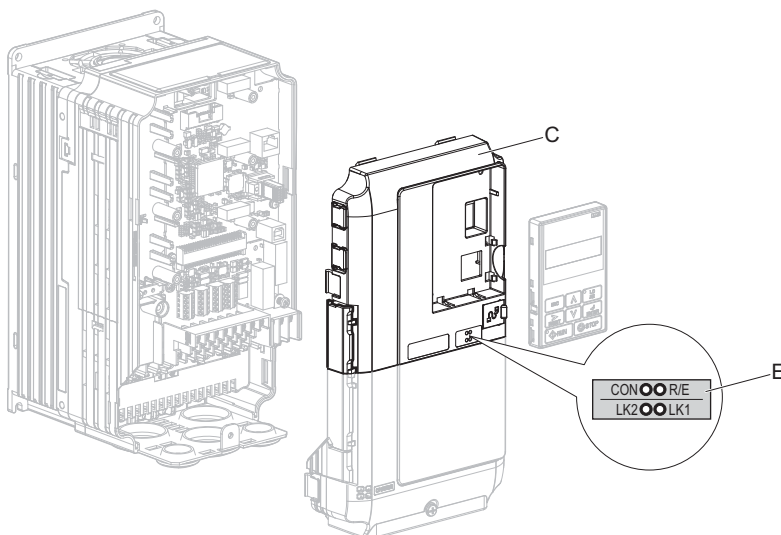

Figure 6 Affix the LED Label

5 Installation Procedure

3. Insert the option card (B) into the CN5-A (M) connector on the drive and fasten it into place using one of the included screws (H). Tighten the screw to 0.5 to 0.6 N·m (4.4 to 5.3 in·lb).

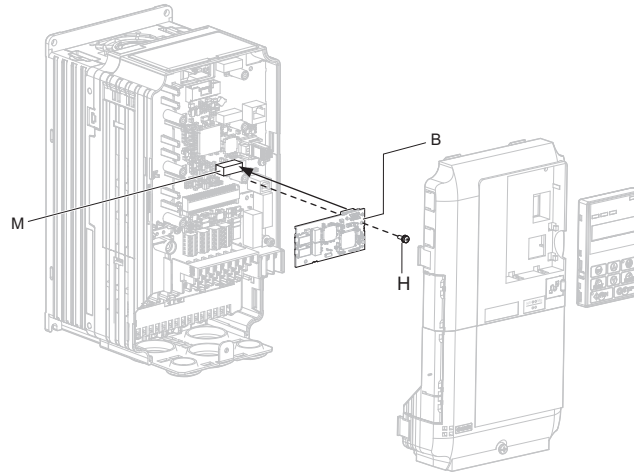

Figure 7 Insert the Option

4. Connect one end of the ground wire (I) to the ground terminal (L) using one of the remaining provided screws (H). Connect the other end of the ground wire (I) to the remaining ground terminal and installation hole on the option (B) using the last remaining provided screw (H). Tighten both screws to 0.5 to 0.6 N·m (4.4 to 5.3 in·lb).

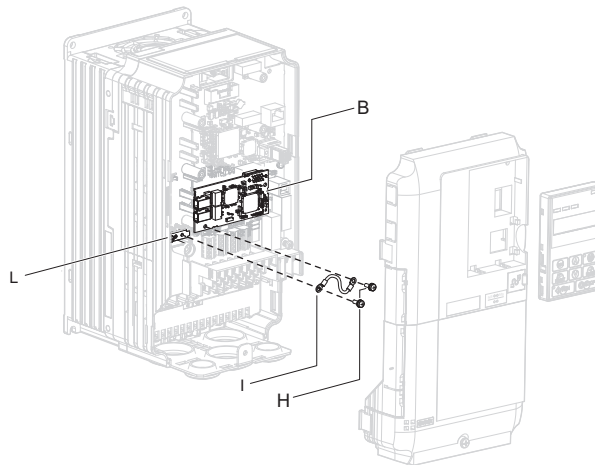
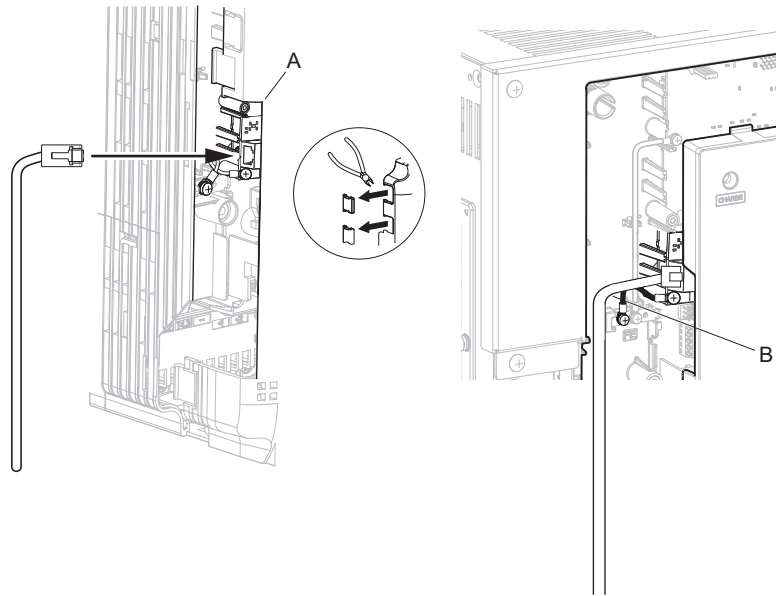

Figure 8 Connect the Ground Wire

Note: The drive has only two ground terminal screw holes (I). Two ground wires should share the same ground terminal when connecting three options.

- Select the proper MECHATROLINK-III dedicated communication cable according to [Table 6](#).
Route the option wiring inside the enclosure as shown in [Figure 9-B](#). Take proper precautions so that the front covers will easily fit back onto the drive.
Users may also choose to route the option wiring through openings on the front cover of some models. Remove the perforated tabs on the left side of the front cover as shown in [Figure 9-A](#) to create the necessary openings on these models.
Refer to the Peripheral Devices & Options section of the drive instruction manual for more information.

Note: Separate communication cables from main circuit wiring and other electrical lines to avoid potential sources of electrical interference.



A – Route wires through the openings provided on the left side of the front cover. <1>

B – Use the open space provided inside the drive to route option wiring.

<1> The drive will not meet Enclosed wall-mounted type (IP20/UL Type 1) requirements if wiring is exposed outside the enclosure.

Figure 9 Wire Routing Examples

- Firmly connect the MECHATROLINK-III communication cable to option communication connector CN1 or CN2. Install MECHATROLINK-III communications cables apart from main-circuit wiring and other electrical and power lines. Ensure the cable end is firmly connected (see [Figure 17](#)). Refer to [MECHATROLINK-III Communications Cables on page 22](#) for details.

Note: Maximum transmission distance is 100 m (328 ft). Minimum wiring distance between stations is 0.2 m (7.9 in).

5 Installation Procedure

- Reattach the drive front covers (C, F) and the keypad (D).

NOTICE: Do not pinch cables between the front covers and the drive. Failure to comply could cause erroneous operation.

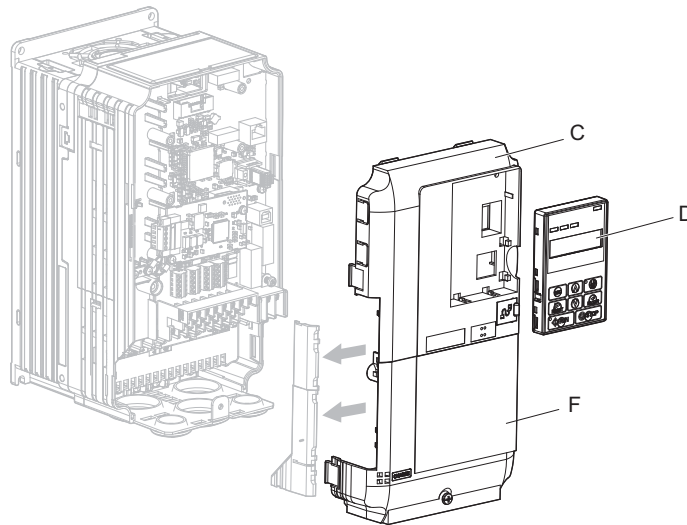

Figure 10 Replace the Front Covers and Keypad

- Set drive parameters in [Table 7](#) for correct option performance.

■ Procedure B

This section shows the procedure to install and wire the option on a GA700, GA800, CR700, or CH700 drive.

Prepare the Drive for the Option

Before you install the option on a YASKAWA AC Drive GA700, GA800, CR700, or CH700, make sure that the option software version is PRG: 6202 or later.

- Correctly wire the drive as specified by the manual packaged with the drive.
- Make sure that the drive functions correctly.

Refer to [Figure 11](#) for an exploded view of the drive with the option and related components for reference in the installation procedure.

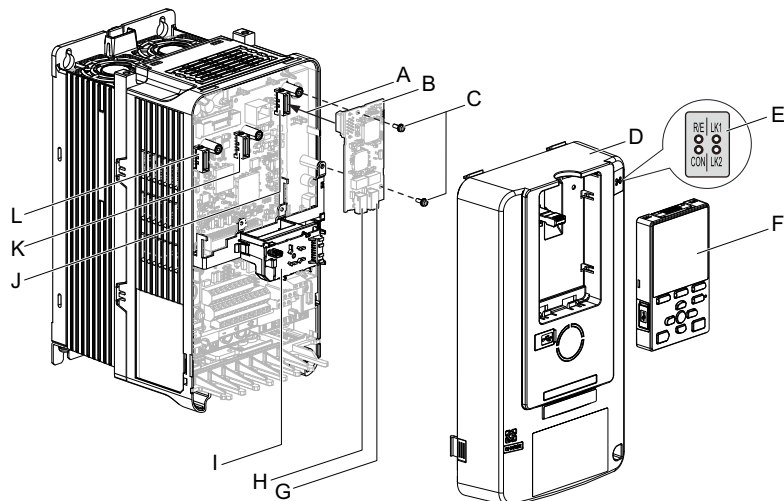

- | | |
|--|--|
| A – Insertion point for CN5 connector | I – LED Status Ring board |
| B – SI-ET3 option | J – Connector CN5-A |
| C – Included screws | K – Connector CN5-B
(Not available for communication option installation.) |
| D – Drive front cover | L – Connector CN5-C
(Not available for communication option installation.) |
| E – LED label | |
| F – Keypad | |
| G – Option modular connector CN1 | |
| H – Option modular connector CN2 | |

Figure 11 Drive Components with Option

Install the Option

Remove the front cover of the drive before you install the option. Refer to the drive manual for information about how to remove the front cover. Different drive sizes have different cover removal procedures. You can only install this option into the **CN5-A** connector on the drive control board.

DANGER! Electrical Shock Hazard. Do not inspect, connect, or disconnect any wiring while the drive is energized. Failure to comply will cause death or serious injury. Before servicing, disconnect all power to the equipment and wait for at least the time specified on the warning label. The internal capacitor remains charged even after the drive is de-energized. The charge indicator LED will extinguish when the DC bus voltage is below 50 Vdc. When all indicators are OFF, measure for unsafe voltages to confirm the drive is safe.

1. Affix the LED label (E) in the appropriate position on the drive front cover (D).

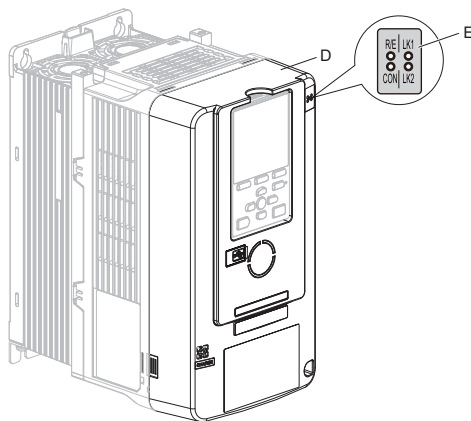

Figure 12 Affix the LED Label

2. Shut off power to the drive, wait the appropriate amount of time for voltage to dissipate, then remove the front cover (D).

Refer to the manual packaged with the drive for details on cover removal.

NOTICE: Damage to Equipment. Observe proper electrostatic discharge (ESD) procedures when handling the option, drive, and circuit boards. Failure to comply could cause ESD damage to circuitry.

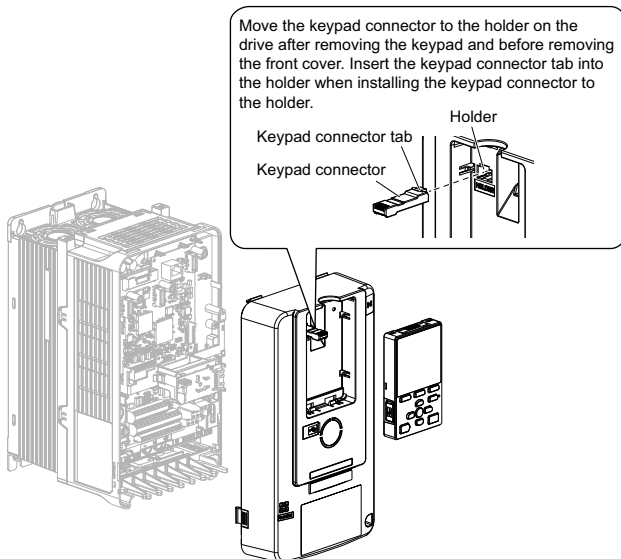

Figure 13 Remove the Front Cover and Keypad

5 Installation Procedure

- Carefully remove the LED Status Ring board (I) and place it on the right side of the drive using the temporary placement holes.
Refer to the manual packaged with the drive for details on removing the LED Status Ring board.

NOTICE: Do not remove the LED Status Ring board cable connector. Failure to comply could cause erroneous operation and damage the drive.

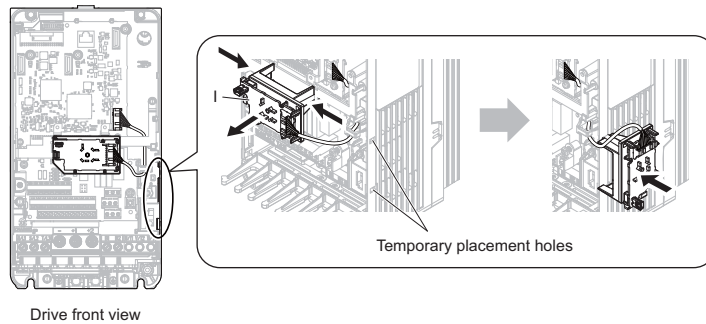

Figure 14 Remove the LED Status Ring Board

- Insert the option card (B) into the CN5-A connector (J) on the drive and fasten it into place using the included screws (C). Tighten both screws to 0.5 to 0.6 N·m (4.4 to 5.3 in·lb).

Note: Only two screws are necessary to install the option on a GA700, GA800, CR700, or CH700 drive. A ground wire is not necessary. The option package ships with three screws and a ground wire for installation on other product series. Do not use the ground wire or the extra screw.

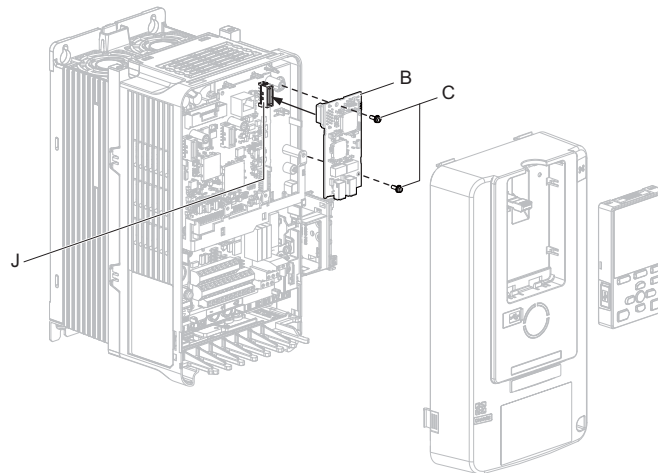

Figure 15 Insert the Option Card

- Select the proper MECHATROLINK-III dedicated communication cable according to [Table 6](#). Firmly connect the MECHATROLINK-III communication cable to option communication connector CN1 or CN2. Install MECHATROLINK-III communications cables apart from main-circuit wiring and other electrical and power lines. Ensure the cable end is firmly connected (see [Figure 17](#)). Refer to [MECHATROLINK-III Communications Cables on page 22](#) for details.

Note: Maximum transmission distance is 100 m (328 ft). Minimum wiring distance between stations is 0.2 m (7.9 in).

6. Reattach the LED Status Ring board (I).
Use the open space provided inside the LED Status Ring board to route option wiring.

NOTICE: Do not pinch cables between the front cover or the LED Status Ring board and the drive. Failure to comply could cause erroneous operation.

7. Reattach the drive front cover (D) and the keypad (F).

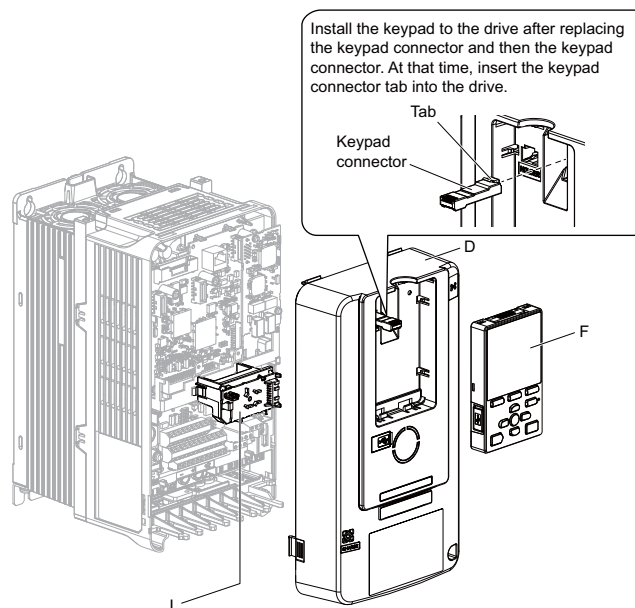

Figure 16 Replace the Front Cover and Keypad

8. Set drive parameters in [Table 7](#) for correct option performance.

◆ MECHATROLINK-III Communications Cables

Connect the MECHATROLINK-III communication cable to option communication connector CN1 or CN2.

Use only MECHATROLINK-III dedicated communication cable. Refer to [Table 6](#) for details.

Note: Maximum transmission distance is 100 m (328 ft). Minimum wiring distance between stations is 0.2 m (7.9 in).

■ Option Connection Diagram

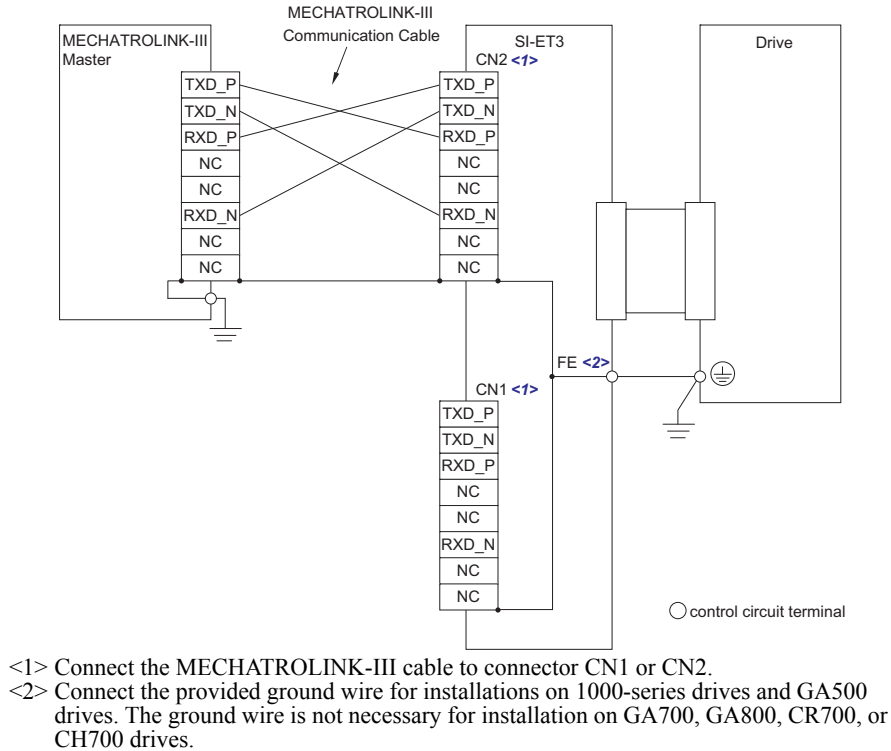

Figure 17 Option Connection Diagram

■ Communication Cable Topology

The dual communication cable ports on the option board act as a switch to allow for flexibility in cabling topology.

Users may employ a traditional star network topology using a single communication cable port on the option.

Users may also choose to employ a ring topology using both communication cable ports on the option and reduce the requirements of MECHATROLINK-III hub module ports.

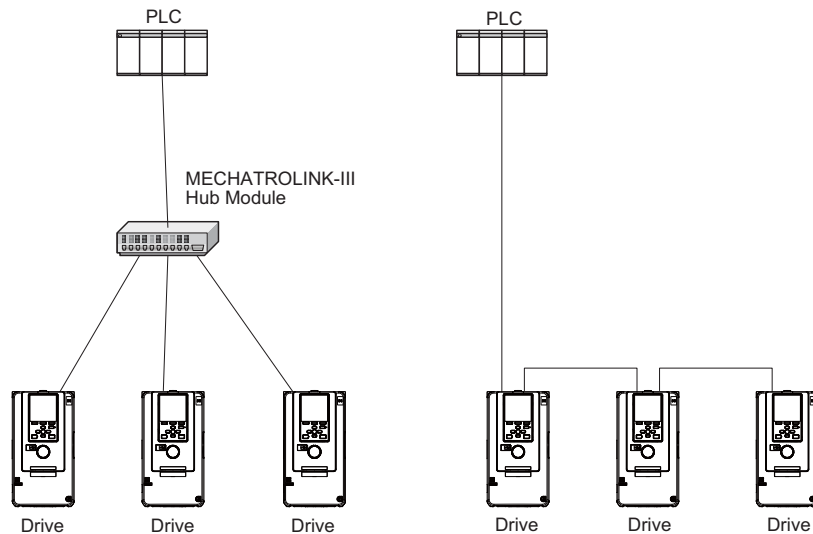
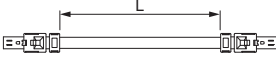
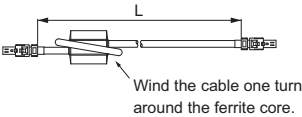
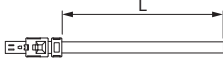

Figure 18 Topology Options

Table 6 MECHATROLINK-III Communication Cable

Connection Type	Cable Specification	Length (L)	Model
MECHATROLINK-III connection without ferrite core		0.2 m (7.9 in)	JEPMC-W6012-A2-E
		0.5 m (19.7 in)	JEPMC-W6012-A5-E
		1 m (39.4 in)	JEPMC-W6012-01-E
		2 m (78.7 in)	JEPMC-W6012-02-E
		3 m (118.1 in)	JEPMC-W6012-03-E
		4 m (157.5 in)	JEPMC-W6012-04-E
		5 m (196.9 in)	JEPMC-W6012-05-E
		10 m (393.7 in)	JEPMC-W6012-10-E
		20 m (787.4 in)	JEPMC-W6012-20-E
		30 m (1181.1 in)	JEPMC-W6012-30-E
		50 m (1968.5 in)	JEPMC-W6012-50-E
MECHATROLINK-III connection with ferrite core		10 m (393.7 in)	JEPMC-W6013-10-E
		20 m (787.4 in)	JEPMC-W6013-20-E
		30 m (1181.1 in)	JEPMC-W6013-30-E
		50 m (1968.5 in)	JEPMC-W6013-50-E
		75 m (2952.8 in)	JEPMC-W6013-75-E
		100 m (3937.0 in)	JEPMC-W6013-100-E
MECHATROLINK-III connection with loose wires at one end		0.5 m (19.7 in)	JEPMC-W6014-A5-E
		1 m (39.4 in)	JEPMC-W6014-01-E
		3 m (118.1 in)	JEPMC-W6014-03-E
		5 m (196.9 in)	JEPMC-W6014-05-E
		10 m (393.7 in)	JEPMC-W6014-10-E
		30 m (1181.1 in)	JEPMC-W6014-30-E
		50 m (1968.5 in)	JEPMC-W6014-50-E

6 Related Drive Parameters

The parameters in **Table 7** set the drive for operation with the option. Confirm proper setting of all parameters in **Table 7** before starting network communications. Refer to the manual packaged with the drive for details on setting parameters.

Note: Hex.: MEMOBUS addresses that you can use to change parameters over network communication are represented in hexadecimal numbers.

Table 7 Related Parameter Settings

No. (Hex.)	Name	Description	Values
b1-01 (0180) </>	Reference 1 Source	Selects the input method for frequency reference. 0: Keypad 1: Analog Input 2: Memobus/Modbus Communications 3: Option PCB 4: Pulse Train Input	Default: <2> Range: 0 to 4 (Set to 3)
b1-02 (0181) </>	Run Command 1 Source	Selects the input method for the Run command. 0: Keypad 1: Digital Input 2: Memobus/Modbus Communications 3: Option PCB	Default: 1 Range: 0 to 3 (Set to 3)
d5-01 (029A)	Torque Control Selection	0: Speed Control 1: Torque Control	Default: 0 Range: 0, 1
F6-01 (03A2)	Communication Error Selection	Selects drive response when a bUS error is detected during communications with the option. 0: Ramp to Stop 1: Coast to Stop 2: Fast Stop (Use C1-09) 3: Alarm Only <3> 4: Alarm - Run at d1-04 <3> <4> 5: Alarm - Ramp to Stop <4>	Default: 1 Range: 0 to 5 <5>
F6-02 (03A3)	Comm External Fault (EF0) Detect	Selects the condition for external fault detection (EF0). 0: Always detected 1: Detection during run only	Default: 0 Range: 0, 1
F6-03 (03A4)	Comm External Fault (EF0) Select	Selects drive response for external fault input (EF0) detection during option communications. 0: Ramp to Stop 1: Coast to Stop 2: Fast Stop (Use C1-09) 3: Alarm Only <3>	Default: 1 Range: 0 to 3
F6-06 (03A7) <6>	Torque Reference/Limit by Comm	Enabling this parameter allows d5-01 to determine whether the value is read as the Torque Limit value (d5-01 = 0) or the Torque Reference value (d5-01 = 1). 0: Disabled 1: Enabled <7>	Default: 0 Range: 0, 1
F6-07 (03A8)	MultiStep Ref Priority Select	0: MultiStep References Disabled 1: MultiStep References Enabled	Default: 0 <8> Range: 0, 1
F6-08 (036A)	Comm Parameter Reset @Initialize	Selects whether communication-related parameters F6-□□ and F7-□□ are set back to original default values when the drive is initialized using parameter A1-03. 0: No Reset - Parameters retained 1: Reset - Back to factory default Note: The setting value is not changed even when F6-08 is set to 1 and the drive is initialized using A1-03.	Default: 0 Range: 0, 1
F6-20 (036B) <9> <10>	MECHATROLINK Station Address	Sets the station number.	Default: 21H Min.: 03H Max.: EFH
F6-21 (036C) <9>	MECHATROLINK Frame Size	Selects the frame size. 0: 64-byte 1: 32-byte	Default: 0 Range: 0, 1
F6-23 (036E) <9> <11>	MECHATROLINK Monitor Select (E)	Set MEMOBUS/Modbus register to monitor SEL_MON of INV_CTL and INV_I/O.	Default: 0H Min.: 0H Max.: FFFFH

No. (Hex.)	Name	Description	Values
F6-24 (036F) <9> <12>	MECHATROLINK Monitor Select (F)	Set MEMOBUS/Modbus register to monitor SEL_MON of INV_CTL and INV_I/O.	Default: 0H Min.: 0H Max.: FFFFH
F6-25 (03C9)	MECHATROLINK Watchdog Error Sel	0: Ramp to Stop 1: Coast to Stop 2: Fast Stop (Use C1-09) 3: Alarm Only <3>	Default: 1 Range: 0 to 3
F6-26 (03CA)	MECHATROLINK bUS Errors Detected	Sets the number bUS alarms necessary to trigger a bUS fault. When the number of option communication alarm bUS exceeds the value set to F6-26, the drive detects option communication fault bUS.	Default: 2 Min.: 2 Max.: 10

- <1> Set b1-02 = 3 to start and stop the drive with the MECHATROLINK-III master device using serial communications.
Set b1-01 = 3 to control the frequency reference of the drive via the master device.
- <2> The default setting is different for different drives. Refer to the instruction manual of a specific drive for more information.
- <3> Setting this parameter to 3 or 4 will cause the drive to continue operation after detecting a fault. Take proper measures such as installing an emergency stop switch when using settings 3 or 4.
- <4> Refer to the drive manual to know if settings 4 and 5 are available. Settings 4 and 5 are available in A1000 software versions PRG: 1021 and later.
- <5> The setting range for 1000-Series drives is different for different software versions. Refer to the instruction manual of a specific drive for more information.
- <6> Control method availability of this parameter depends on product series.
- 1000-Series Drives: Parameter is available in CLV, AOLV/PM, and CLV/PM.
In AOLV/PM, this value is read as the Torque Limit.
 - GA500 Drive: Parameter is available in OLV, AOLV/PM, and EZOLV.
This value is read as the Torque Limit.
 - GA700, GA800 Drives: Parameter is available in OLV, CLV, AOLV, AOLV/PM, CLV/PM, and EZOLV.
In OLV and EZOLV, this value is read as the Torque Limit.
 - CR700, CH700 Drives: Parameter is available in OLV, CLV, and AOLV.
This value is read as the Torque Limit.
- <7> The setting specifies that network communications provide the torque reference or torque limit. The motor may not rotate if the PLC does not supply a torque reference or torque limit.
- <8> Default setting is 1 for GA500.
- <9> Cycle power for setting changes to take effect.
- <10> All station addresses must be unique. If set to 20 or 3F, a Station Address Error (AEr) will occur and the ERR light will turn on.
- <11> Set byte 21, SEL_MON1/2 of INV_CTL, or byte 38, SEL_MON 3/4 and byte 39, SEL_MON 5/6 of INV_I/O to 0EH to enable the register set with F6-23. Bytes of the response data enable the register content set with F6-23. Refer to the manual packaged with the drive for details on settable registers.
- <12> Set byte 21, SEL_MON1/2 of INV_CTL, or byte 38, SEL_MON 3/4 and byte 39, SEL_MON 5/6 of INV_I/O to 0FH to enable the register set with F6-24. Bytes of the response data enable the register content set with F6-24. Refer to the manual packaged with the drive for details on settable registers.

7 Transmission Interface

◆ MECHATROLINK-III Cyclic Transmissions

As a MECHATROLINK-III station, the SI-ET3 option exchanges control data and I/O data with a control device. The option sends response data timed to the reception of command data for the local station address from the master in each transmission cycle to communicate.

The command and response data formats follow the specifications for the MECHATROLINK Drive commands.

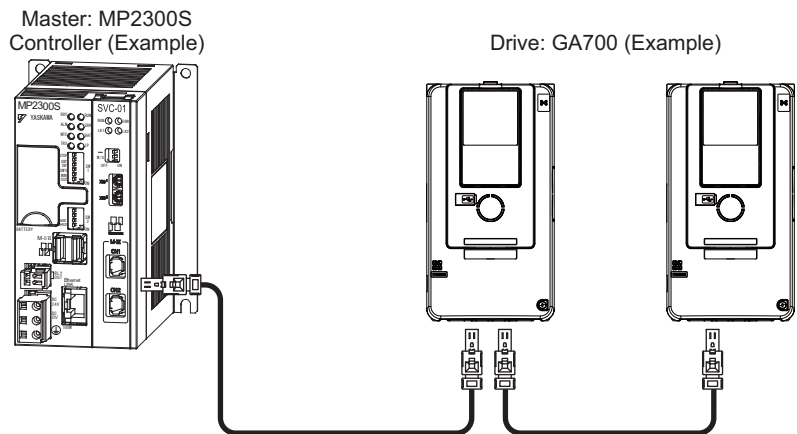
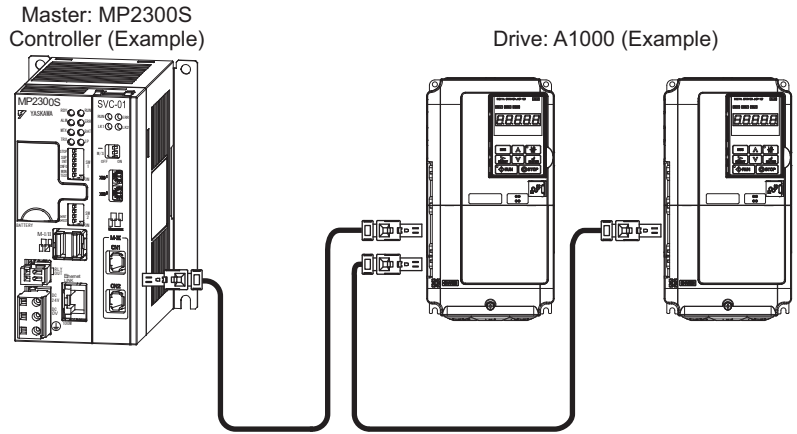

◆ Command Format of the Standard Profile Common Commands

This section describes the specifications of the standard profile common commands.

Table 8 lists the data format and the common commands and responses.

Standard inverter profile commands fix the data length at 32 bytes for main commands and sub-commands.

Table 8 Command Format of the Standard Profile Common Commands

–	Byte	Command	Response	Reference
Main Commands	0	CMD	RCMD	<ul style="list-style-type: none"> • CMD/RCMD Command code specified for individual commands. Refer to <i>Main Command on page 33</i>. • WDT/RWDT Watchdog data is usually set automatically. • CMD_CTRL Refer to <i>Command Control (CMD_CTRL) on page 31</i>. • CMD_STAT Refer to <i>Command Status (CMD_STAT) on page 31</i>. • CMD_DATA/RSP_DATA Specified for individual commands. Refer to <i>Main Command on page 33</i>.
	1	WDT	RWDT	
	2	CMD_CTRL	CMD_STAT	
	3			
	4	CMD_DATA	RSP_DATA	
	5			
	6			
	7			
	8			
	9			
	10			
	11			
	12			
	13			
	14			
	15			
	16			
	17			
	18			
	19			
	20			
	21			
	22			
	23			
	24			
	25			
	26			
	27			
	28			
	29			
	30			
31				
Sub-Commands	32	SUBCMD	RSUBCMD	<ul style="list-style-type: none"> • SUBCMD/RSUBCMD Command code specified for individual commands. Refer to <i>Sub-Commands on page 47</i>. • SUB_CTRL Refer to <i>SUB_CTRL (Sub-Command Control Field) on page 47</i>. • SUB_STAT Refer to <i>SUB_STAT (Sub-Command Status) on page 47</i>. • SUB_CMD_DATA/SUB_RSP_DATA Specified for individual commands. Refer to <i>Sub-Commands on page 47</i>.
	33	SUB_CTRL	SUB_STAT	
	34			
	35	SUB_CMD_DATA	SUB_RSP_DATA	
	36			
	37			
	38			
	•			
	•			
	59			
60				
61				

◆ Communication Phases

The SI-ET3 option changes status after receiving a command code or fault from the master as shown in *Figure 19*.

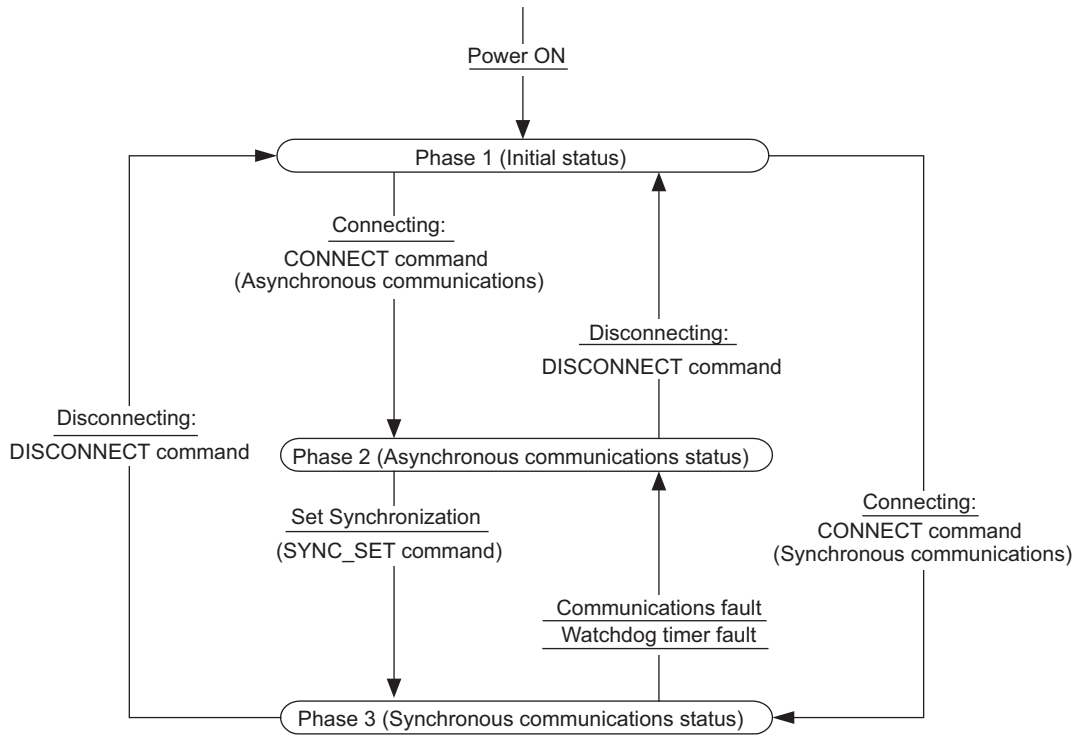

Figure 19 Communication Phases

■ Phase 1: Initial status after power ON

Operation proceeds with a default transmission cycle of 2 ms. The transmission cycle is changed to the time indicated in the synchronous frame when a CONNECT command is received from the master. Then the phase moves to phase 2 or phase 3 after a response to the CONNECT command is returned.

Even if a transfer fault is detected in phase 1, no fault notification is provided.

■ Phase 2: Asynchronous communications

All SI-ET3 commands can be used. Phase 2 starts to count the watchdog timer in the communications frame. The phase moves to phase 3 when a SYNC_SET command is received, and it moves to phase 1 when a DISCONNECT command is received.

■ Phase 3: Synchronous communications

Watchdog timer faults in the communications frame are detected. The phase moves to phase 1 if the DISCONNECT command is received. The phase moves to phase 2 if a reception fault or a watchdog timer fault is detected.

The communication phases determine the available commands. Refer to [Table 9](#) and [Table 10](#) for details.

Table 9 Main Command Communication Phases

Command	Code [HEX]	Contents	Communication Phase		
			1	2	3
NOP	00	No Operation Command	–	○	○
PRM_RD	01	Read Parameter Command	–	○	○
PRM_WR	02	Write Parameter Command	–	○	○
ID_RD	03	Read ID Command	–	○	○
CONFIG	04	Setup Device Command	–	○	○
ALM_RD	05	Read Alarm or Warning Command	–	○	○
ALM_CLR	06	Clear Alarm or Warning Command	–	○	○
SYNC_SET	0D	Start Synchronous Communication Command	–	○	△
CONNECT	0E	Establish Connection Command	○	△	△
DISCONNECT	0F	Release Connection Command	○	○	○
INV_CTL	50	Inverter Operation Control Command	–	○	○

○: Can be executed

△: Ignored

–: Cannot be executed (phase error)

Table 10 Sub-Command Communication Phases

Command	Code [HEX]	Contents	Communication Phase		
			1	2	3
NOP	00	No Operation Command	–	○	○
PRM_RD	01	Read Parameter Command	–	○	○
PRM_WR	02	Write Parameter Command	–	○	○
ALM_RD	05	Read Alarm or Warning Command	–	○	○
INV_IO	51	Drive I/O Control Command	–	○	○

○: Can be executed

–: Cannot be executed (phase error)

◆ Application Layer Specifications

The data format for the application layer conforms to the MECHATROLINK-III command specifications for standard inverter profile.

The SI-ET3 option uses the main commands and sub-commands in [Table 11](#) and [Table 12](#).

Table 11 Main Commands

Code [HEX]	Name	Function
00	NOP	No Operation Command
01	PRM_RD	Read Parameter Command
02	PRM_WR	Write Parameter Command
03	ID_RD	Read ID Number Command
04	CONFIG	RAM Write and EEPROM Write Command
05	ALM_RD	Read Alarm and Warning Command
06	ALM_CLR	Clear Alarm and Warning Command
0D	SYNC_SET	Start Synchronous Communications Command
0E	CONNECT	Connect Command
0F	DISCONNECT	Disconnect Command
50	INV_CTL	Inverter Operation Control Command

Table 12 Sub-Commands

Code [HEX]	Name	Function
00	NOP	No Operation Command
01	PRM_RD	Read Parameter Command
02	PRM_WR	Write Parameter Command
05	ALM_RD	Read Alarm and Warning Command
51	INV_I/O	Inverter I/O Control Command

Set F6-21 = 0 to select 64-byte data transmission prior to using sub-commands.

The request for the main command is processed if a conflict occurs between a request for a main command and a request for a subcommand.

The command being processed is given priority if either a main command or a sub-command is already being processed. The sub-command is given priority if an INV_CTL main command and an INV_I/O sub-command conflict.

Refer to [MECHATROLINK-III Commands on page 31](#) for details on command formats.

[Table 13](#) shows the combinations of main commands and sub-commands.

Table 13 Main Commands and Sub-Commands

Code [HEX]	Main Command	Sub-Command				
		NOP (00H)	PRM_RD (01H)	PRM_WR (02H)	ALM_RD (05H)	INV_I/O (51H)
00	NOP	OK	OK	OK	OK	OK
01	PRM_RD	OK	-	-	OK	OK
02	PRM_WR	OK	-	-	OK	OK
03	ID_RD	OK	OK	OK	OK	OK
04	CONFIG	OK	-	-	-	-
05	ALM_RD	OK	-	-	-	-
06	ALM_CLR	OK	-	-	-	-
0D	SYNC_SET	OK	OK	OK	OK	OK
0E	CONNECT	OK	-	-	-	-
0F	DISCONNECT	OK	-	-	-	-
50	INV_CTL	OK	OK	OK	OK	OK

Note: CMD_ALM = BH (sub-command combination error) will result if a main command and sub-command conflict with one another.

8 MECHATROLINK-III Commands

◆ Command Control (CMD_CTRL)

Bit 7	Bit 6	Bit 5	Bit 4	Bit 3	Bit 2	Bit 1	Bit 0
CMD_ID		Reserved (0)	Reserved (0)	ALM_CLR	Reserved (0)	Reserved (0)	Reserved (0)
Bit 15	Bit 14	Bit 13	Bit 12	Bit 11	Bit 10	Bit 9	Bit 8
Reserved (0)							

Command	Description
CMD_ID	This is not used with standard inverter profile commands.
ALM_CLR	0: Clear alarm/warning disabled 1: Clear alarm/warning triggered The same processing as when ALM_CLR_MODE = 0 for the ALM_CLR command (the current alarm/warning state is cleared) is performed.

■ Command Status (CMD_STAT)

Bit 7	Bit 6	Bit 5	Bit 4	Bit 3	Bit 2	Bit 1	Bit 0
RCMD_ID		Reserved (0)	Reserved (0)	ALM_CLR_CMP	CMDRDY	D_WAR	D_ALM
Bit 15	Bit 14	Bit 13	Bit 12	Bit 11	Bit 10	Bit 9	Bit 8
COMM_ALM				CMD_ALM			

Command	Description
RCMD_ID	The slave returns the echo of the CMD_ID as the RCMD_ID.
ALM_CLR_CMP	ALM_CLR_CMP = 1 means that CMD_CTRL.ALM_CLR = 1 has been received and alarm clear processing has been completed.
CMDRDY	1: Command reception enabled 0: Other
D_WAR	0: Normal operation 1: The device is in the warning state.
D_ALM	0: Normal operation 1: The device is in the alarm state.
COMM_ALM	Notifies the communication error state. COMM_ALM is independent of CMD_ALM, D_ALM and D_WAR. COMM_ALM is cleared at the leading edge of CMD_CTRL.ALM_CLR or by the ALM_CLR command. Refer to COMM_ALM on page 31 for details.
CMD_ALM	Notifies the command error state. If a normal command is received after the occurrence of a command error, CMD_ALM is automatically cleared. Refer to COMM_ALM on page 31 for details.

■ COMM_ALM

Code [HEX]		Contents
–	0	Normal
Warning	1	Frame Check Sequence (FCS) error
	2	Command data not received
	3	Synchronous frame not received
Alarm	8	Frame Check Sequence (FCS) error
	9	Command data not received
	A	Synchronous frame not received
	B	Synchronization interval error
	C	WDT error

■ CMD_ALM

Code [HEX]		Contents
-	0	Normal
Warning	1	Invalid data
Alarm	8	Unsupported command received
	9	Invalid data
	A	Command execution condition error
	B	Sub-command combination error
	C	Phase error

9 Main Command

◆ NOP: 00H (No Operation Command)

The NOP command is used for network control. The current state is returned as a response. The command can be used in all communication phases.

NOP command		
Byte	Command	Description
0	NOP (00H)	Command code
1	WDT	Watchdog data
2	CMD_CTRL	Refer to <i>Command Control (CMD_CTRL) on page 31.</i>
3		
4	Reserved (0)	Not used
5		
.		
.		
31		

NOP Response		
Byte	Response	Description
0	NOP (00H)	Command code
1	RWDT	Watchdog data
2	CMD_STAT	Refer to <i>Command Status (CMD_STAT) on page 31.</i>
3		
4	Reserved (0)	Not used
5		
.		
.		
31		

◆ PRM_RD: 01H (Read Parameter Command)

The PRM_RD command specifies the parameter number and the data size to read a parameter. The command can be used in communication phases 2 and 3. Refer to the drive manual for details on MEMOBUS/Modbus register numbers.

PRM_RD command		
Byte	Command	Description
0	PRM_RD (01H)	Command code
1	WDT	Watchdog data
2	CMD_CTRL	Refer to <i>Command Control (CMD_CTRL) on page 31.</i>
3		
4	NO	MEMOBUS/Modbus register number (Lower)
5		MEMOBUS/Modbus register number (Upper)
6	SIZE	Data size to read [units: byte] Available setting values are 2, 4, 6, and 8.
7	Reserved (0)	Not used
8	Reserved (0)	
9		
10		
.		
.		
31		

9 Main Command

PRM_RD Response		
Byte	Response	Description
0	PRM_RD (01H)	Command code
1	RWDT	Watchdog data
2	CMD_STAT	Refer to Command Status (CMD_STAT) on page 31 .
3		If the SIZE data is invalid or MEMOBUS/Modbus register number does not exist, "9" is set for CMD_ALM.
4	NO	MEMOBUS/Modbus register number (Lower) set in the command.
5		MEMOBUS/Modbus register number (Upper) set in the command.
6	SIZE	The SIZE is the same as the register number set in MEMOBUS/Modbus transfers.
7	Reserved (0)	0 is set.
8	PARAMETER	Sets the data read in the byte set in the command. The option stores the data read for PARAMETER from lower byte (LSB) to upper byte (MSB). 0 is stored when the field is not used. 0 is stored in PARAMETER when command error occurs.
9		
10		
.		
.		
31		

Example: Reading C1-01 (200H)

Byte	Command	Response
4	00H	00H
5	02H	02H
6	02H	02H
7	00H	00H
8	00H	Value set to C1-01 (Lower)
9	00H	Value set to C1-01 (Upper)

◆ PRM_WR: 02H (Write Parameter Sub-Command)

The PRM_WR command specifies the parameter number, data size, and parameter data to write a parameter. The command can be used in communication phases 2 and 3. The CONFIG command must be sent to set up after the parameters are written. Refer to the drive manual for details on MEMOBUS/Modbus register numbers.

PRM_WR Command		
Byte	Command	Description
0	PRM_WR (02H)	Command code
1	WDT	Watchdog data
2	CMD_CTRL	Refer to Command Control (CMD_CTRL) on page 31 .
3		
4	NO	MEMOBUS/Modbus register number (Lower)
5		MEMOBUS/Modbus register number (Upper)
6	SIZE	Set the data size in byte. Available setting values are 2, 4, 6, and 8
7	Reserved (0)	Not used
8	PARAMETER	Specify the lower byte (LSB) before the upper byte (MSB) in the size set in the SIZE.
9		
10		
.		
.		
31		

PRM_WR Response		
Byte	Response	Description
0	PRM_WR (02H)	Command code
1	RWDT	Watchdog data
2	CMD_STAT	Refer to <i>Command Status (CMD_STAT) on page 31</i> .
3		If the SIZE data is invalid, "9" is set for CMD_ALM.
4	NO	MEMOBUS/Modbus register number (Lower) set in the command.
5		MEMOBUS/Modbus register number (Upper) set in the command.
6	SIZE	The value set in the command.
7	Reserved (0)	0 is set.
8	PARAMETER	The value set in the command. 0 is stored when the field is not used.
9		
10		
.		
31		

In the following status, an alarm is detected and the command goes into error.

Error	Response
Register Number Error	"9" is set for CMD_ALM.
Bit Count Error	"9" is set for CMD_ALM.
Data Setting Error	"9" is set for CMD_ALM.
Write Mode Error	"9" is set for CMD_ALM.
Writing Error during Under Voltage	"9" is set for CMD_ALM.
Writing Error during Parameter Processing	"9" is set for CMD_ALM.

Example: Writing C1-01 (200H)

Byte	Command	Response
4	00H	00H
5	02H	02H
6	02H	02H
7	00H	00H
8	Value set to C1-01 (Lower)	Value set to C1-01 (Lower)
9	Value set to C1-01 (Upper)	Value set to C1-01 (Upper)

◆ ID_RD: 03H (Read ID Command)

The ID_RD command reads the product information as ID data to read the ID of a device.

ID_RD command		
Byte	Command	Description
0	ID_RD (03H)	Command code
1	WDT	Watchdog data
2	CMD_CTRL	Refer to <i>Command Control (CMD_CTRL) on page 31</i> .
3		
4	ID_CODE	Specifies the ID_CODE. Refer to <i>Table 14</i> for details.
5	OFFSET	Set the offset in byte.
6	SIZE	Set the size in byte. (Lower)
7		Set the size in byte. (Upper)
8	Reserved (0)	Not used
.		
.		
31		

ID_RD Response		
Byte	Response	Description
0	ID_RD (03H)	Command code
1	RWDT	Watchdog data
2	CMD_STAT	Refer to <i>Command Status (CMD_STAT) on page 31</i> .
3		
4	ID_CODE	MEMOBUS/Modbus register number (Lower) set in the command.
5	OFFSET	MEMOBUS/Modbus register number (Upper) set in the command.
6	SIZE	The value set in the command.
7		
8	ID	ID data is stored. Refer to <i>Table 14</i> for details.
.		
.		
31		

Table 14 ID_CODE

ID_CODE	Name	Size	Description
01H	Vendor ID Code	4 byte	0000H
02H	Device Code	4 byte	1000-Series Drives: 04000001H GA500, GA700, GA800, CR700, and CH700: 04000002H
03H	Device Version	4 byte	Version information of device
04H	Device Definition File Version	4 byte	0000H
05H	Extended Address Setting	4 byte	0001H (Multi-slave is not available)
10H	Profile type 1 (Primary)	4 byte	0020H (Inverter profile)
11H	Profile Version 1 (Primary)	4 byte	0100H
12H	Profile Type 2	4 byte	00FFH (Not available)
13H	Profile Version 2	4 byte	0000H (Not available)
14H	Profile Type 3	4 byte	00FFH (Not available)
15H	Profile Version 3	4 byte	0000H (Not available)
16H	Minimum Value of Transmission Cycle	4 byte	25000 (250 μ s) [unit: 0.01 μ s]
17H	Maximum Value of Transmission Cycle	4 byte	800000 (8 ms) [unit: 0.01 μ s]
18H	Transmission Cycle Increment (Granularity)	4 byte	03H (Supports 31.25 μ s], 62.5 μ s], 125 μ s], 250 μ s], 500 μ s], 750 μ s], 1 to 64 [ms] (0.5 ms increment))
19H	Minimum Value of Communication Cycle	4 byte	25000 (250 μ s) [unit: 0.01 μ s]
1AH	Maximum Value of Communication Cycle	4 byte	3200000 (32 ms) [ms: 0.01 μ s]
1BH	Number of Transmission Bytes	4 byte	00000014H (64 byte, 32 byte)
1CH	Number of Transmission Bytes (Current Setting)	4 byte	The number of transmission bytes for cyclic communication that is currently set for the device.
1DH	Profile Type (Current Selection)	4 byte	This is the profile selected with the CONNECT command.
20H	Supported Communication Mode	4 byte	00000003H (Cyclic communication/event driven communication)
30H	List of Supported Main Commands	32 byte	The list of the main commands that the device supports.
38H	List of Supported Sub-Commands	32 byte	The list of the sub-commands that the device supports.
40H	List of Supported Common Parameters	32 byte	0
48H	Speed reference unit/Output reference unit	4 byte	0: 0.01 Hz units 1: 0.01% units 2: min ⁻¹ (r/min) units 3: Units in the product specifications 4 and above: Reserved
49H	Torque Reference Unit	4 byte	0: 0.1% units
4AH	Output Current Unit	4 byte	0: 0.1 A units

Access the MECHATROLINK Members Association web site <http://www.mechatrolink.org/> for details on the ID_CODE.

◆ CONFIG: 04H (Setup Device Command)

The CONFIG command forces the parameters written using PRM_WR to become effective, and optionally stores the parameters into EEPROM. The command can be used in communication phases 2 and 3.

CONFIG Command		
Byte	Command	Description
0	CONFIG (04H)	Command code
1	WDT	Watchdog data
2	CMD_CTRL	Refer to <i>Command Control (CMD_CTRL) on page 31</i>
3		
4	CONFIG_MOD	Specify the type of setup. Refer to <i>Table 15</i> for details.
5	Reserved (0)	Not used
6		
7		
.		
.		
.		
31		

CONFIG Response		
Byte	Command	Description
0	CONFIG (04H)	Command code
1	RWDT	Watchdog data
2	CMD_STAT	Refer to <i>Command Status (CMD_STAT) on page 31</i> .
3		
4	CONFIG_MOD	The value set in the command
5	Reserved (0)	Not used
6		
7		
.		
.		
.		
31		

The values available in CONFIG_MOD are listed in *Table 15*.

Table 15 CONFIG_MOD

CONFIG_MOD	Description
0	RAM Write The setting value is not stored in EEPROM.
1	The setting value is stored in EEPROM. Note: The EEPROM can only be written to 100,000 times, so it is recommended to limit the number of times writing to the EEPROM. Issue the CONFIG command after changing all the parameters.

◆ ALM_RD: 05H (Read Alarm or Warning Command)

The ALM_RD command reads the alarm or warning state. The command can be used in communication phases 2 and 3. The current alarm or warning state is read from ALM_DATA as an alarm or warning code. Refer to the drive manual for details about ALM_DATA.

ALM_RD Command		
Byte	Command	Description
0	ALM_RD (05H)	Command code
1	WDT	Watchdog data
2	CMD_CTRL	Refer to <i>Command Control (CMD_CTRL) on page 31</i> .
3		

ALM_RD Command		
Byte	Command	Description
4	ALM_RD_MOD	Specify the alarm or warning state. (Lower)
5		Specify the alarm or warning state. (Upper)
6	ALM_INDEX	Specify the alarm index. The command is enabled when ALM_RD_MODE is 2. (Lower)
7		Specify the alarm index. The command is enabled when ALM_RD_MODE is 2. (Upper)
8	Reserved (0)	Not used
9		
10		
.		
.		
31		

ALM_RD Response		
Byte	Response	Description
0	ALM_RD (05H)	Command code
1	RWDT	Watchdog data
2	CMD_STAT	Refer to <i>Command Status (CMD_STAT) on page 31.</i>
3		
4	ALM_RD_MOD	The value set in the command
5	ALM_INDEX	The value set in the command
6		
7	ALM_DATA	ALM_DATA specifies an alarm using 2 bytes.
8		
9		
10		
.		
31		

Table 16 ALM_RD_MOD

Byte	ALM_RD_MOD = 0	ALM_RD_MOD = 1	ALM_RD_MOD = 2
4	00H	01H	02H
5	00H	00H	00H
6	–	–	ALM_INDEX (Lower)
7	–	–	ALM_INDEX (Upper)
8	U2-01 (Lower)	U3-01 (Lower)	ALM_INDEX = 0: U2-01 (Lower) ALM_INDEX ≠ 0: U3-(ALM_INDEX) (Lower)
9	U2-01 (Upper)	U3-01 (Upper)	ALM_INDEX = 0: U2-01 (Upper) ALM_INDEX ≠ 0: U3-(ALM_INDEX) (Upper)
10	U2-02 (Lower)	U3-02 (Lower)	–
11	U2-02 (Upper)	U3-02 (Upper)	–
12	–	U3-03 (Lower)	–
13	–	U3-03 (Upper)	–
14	–	U3-04 (Lower)	–
15	–	U3-04 (Upper)	–
16	–	U3-05 (Lower)	–
17	–	U3-05 (Upper)	–
18	–	U3-06 (Lower)	–
19	–	U3-06 (Upper)	–
20	–	U3-07 (Lower)	–
21	–	U3-07 (Upper)	–
22	–	U3-08 (Lower)	–

Byte	ALM_RD_MOD = 0	ALM_RD_MOD = 1	ALM_RD_MOD = 2
23	–	U3-08 (Upper)	–
24	–	U3-09 (Lower)	–
25	–	U3-09 (Upper)	–
26	–	U3-10 (Lower)	–
27	–	U3-10 (Upper)	–

Table 17 ALM_DATA

ALM_RD_MOD	Description	
0	Present fault (Byte 6), Fault history Byte 8 to 11	U2-01, U2-02
1	Alarm status list (Byte 8 to 27)	U3-01 to U3-10
2	Fault history (Alarms are not saved in the history.) (Byte 8 to 9)	U2-01, U3-01 to U3-10

◆ ALM_CLR: 06H (Clear Alarm or Warning Command)

The ALM_CLR command clears the alarm or warning state after the cause has been removed. The command can be used in communication phases 2 and 3.

This command changes the state of a slave station; it does not remove the cause of a fault.

ALM_RD Command		
Byte	Command	Description
0	ALM_RD (06H)	Command code
1	WDT	Watchdog data
2	CMD_CTRL	Refer to Command Control (CMD_CTRL) on page 31 .
3		
4	ALM_CLR_MOD	0: Clears the status of present faults and alarms.
5		
6	Reserved (0)	Not used
7		
·		
·		
31		

ALM_RD Response		
Byte	Command	Description
0	ALM_RD (06H)	Command code
1	RWDT	Watchdog data
2	CMD_STAT	Refer to Command Status (CMD_STAT) on page 31 .
3		
4	ALM_CLR_MOD	The value set in the command
5		
6	Reserved (0)	Not used
7		
·		
·		
31		

◆ **SYNC_SET: 0DH (Start Synchronous Communication Command)**

The SYNC_SET command starts synchronous communications. This command also restores synchronous if communications become asynchronous due to any fault. The command can be used in communication phases 2 and 3. Completing this command commences watchdog data error detection.

SYNC_SET command		
Byte	Command	Description
0	SYNC_SET (0DH)	Command code
1	WDT	Watchdog data
2	CMD_CTRL	Refer to <i>Command Control (CMD_CTRL) on page 31</i> .
3		
4	Reserved (0)	Not used
5		
6		
7		
.		
.		
.		
31		

SYNC_SET Response		
Byte	Command	Description
0	SYNC_SET (0DH)	Command code
1	RWDT	Watchdog data
2	CMD_STAT	Refer to <i>Command Status (CMD_STAT) on page 31</i> .
3		
4	Reserved (0)	Not used
5		
6		
7		
.		
.		
.		
31		

◆ **CONNECT: 0EH (Establish Connection Command)**

The CONNECT command establishes a MECHATROLINK connection. The phase moves to communication phase 2 and 3 after the connection is established.

CONNECT Command		
Byte	Command	Description
0	CONNECT (0EH)	Command code
1	WDT	Watchdog data
2	CMD_CTRL	Refer to <i>Command Control (CMD_CTRL) on page 31</i> .
3		
4	VER	Specify 30H.
5	COM_MOD	Specify the Communication Mode (COM_MOD). Refer to <i>Table 18</i> for details.
6	COM_TIM	1 to 255 Sets multiples of the transmission cycle as the communication cycle.
7	PROFILE_TYPE	Specify PROFILE_TYPE = 20H.
8	Reserved (0)	Not used
.		
.		
31		

CONNECT Response		
Byte	Command	Description
0	CONNECT (0EH)	Command code
1	RWDT	Watchdog data
2	CMD_STAT	Refer to <i>Command Status (CMD_STAT)</i> on page 31.
3		
4		
5	VER	The value set in the command
6	COM_MOD	The value set in the command
7	COM_TIM	The value set in the command
8	PROFILE_TYPE	The value set in the command
.	Reserved (0)	Not used
.		
31		

Table 18 COM_MOD

Bit 7	Bit 6	Bit 5	Bit 4	Bit 3	Bit 2	Bit 1	Bit 0
SUBCMD	0	0	0	DTMODE		SYNCMODE	0

Table 19 COM_MOD Bits

Bit	Name	Value	Description
SUBCMD	Sub-command setting	0	Sub-command disabled
		1	Sub-command enabled
DTMODE	Data transfer method	0	Single transmission
SYNCMODE	Synchronization setting	0	Performs synchronous communication
		1	Performs asynchronous communication

◆ DISCONNECT: 0FH (Release Connection Command)

The DISCONNECT command releases the connection. The communication phase shifts to communication phase 1 after this command is completed.

DISCONNECT Command		
Byte	Command	Description
0	DISCONNECT (0FH)	Command code
1	Reserved (0)	Not used
.		
31		

DISCONNECT Response		
Byte	Response	Description
0	DISCONNECT (0FH)	Command code
1	Reserved (0)	Not used
.		
31		

◆ INV_CTL: 50H (Inverter Operation Control Command)

The INV_CTL command sets the drive operation signals and speed references. Parameter o1-03 sets units for speed reference and output frequency. This command can be used in communication phases 2 and 3.

INV_CTL Response		
Byte	Response	Description
0	INV_CTL (50H)	Command code
1	WDT	Watchdog data
2	CMD_CTRL	Refer to <i>Command Control (CMD_CTRL) on page 31</i>
3		
4		
5	INVCMD_CTRL	Refer to <i>INVCMD_CTRL on page 42.</i>
6		
7		
8	INVCMD_IO	Refer to <i>INVCMD_IO Command on page 43.</i>
9		
10		
11		
12	Speed reference	Speed Reference (Lower)
13		Speed Reference (Upper)
14		Not used (Set to 0.)
15		Not used (Set to 0.)
16	Torque reference	Torque Reference (Lower)
17		Torque Reference (Upper)
18		Not used (Set to 0.)
19		Not used (Set to 0.)
20	SEL_REF1/2	Use the SEL REF1/2 command to select the contents of REF1 with bits 0 to 3 and to select the contents of REF2 with bits 4 to 7. Refer to Table 21 for the selection ranges for SEL REF1/2 and SEL MON1/2.
21	SEL_MON1/2	Use the SEL MON1/2 command to select the contents of MON1 with bits 0 to 3 and to select the contents of MON2 with bits 4 to 7.
22	Reserved (0)	Not used (Set to 0.)
23		
24	Reference selected with SEL_REF1	Reference selected with SEL_REF1 (Lower)
25		Reference selected with SEL_REF1 (Upper)
26		Not used (Set to 0.)
27		Not used (Set to 0.)
28	Reference selected with SEL_REF2	Reference selected with SEL_REF2 (Lower)
29		Reference selected with SEL_REF2 (Upper)
30		Not used (Set to 0.)
31		Not used (Set to 0.)

■ INVCMD_CTRL

Vender Specific						Bit 1	Bit 0
Bit 7	Bit 6	Bit 5	Bit 4	Bit 3	Bit 2		
Not used						Reverse operation	Forward operation
Vender Specific						Bit 9	Bit 8
Bit 15	Bit 14	Bit 13	Bit 12	Bit 11	Bit 10		
Not used			Refer to Table 20.			Fault reset	Reserved (0)
Vender Specific							
Bit 23	Bit 22	Bit 21	Bit 20	Bit 19	Bit 18	Bit 17	Bit 16
Not used		1000-Series Drives, GA700, GA800, CR700, and CH700: Multi-Function Input Terminal 3 to 8 GA500: Multi-Function Input Terminal 3 to 7					
Bit 31	Bit 30	Bit 29	Bit 28	Bit 27	Bit 26	Bit 25	Bit 24
Reserved (0)							

Table 20 INVCMD_CTRL Bits

Bit	Name	Description
0	Forward operation	0: Stop 1: Forward operation
1	Reverse operation	0: Stop 1: Reverse operation
9	Fault reset	1: Fault reset
10	External fault (EF0)	1: External fault input (EF0)
11	Clear the fault history	1: Clear fault history
12	External base block reference	1: External base block reference ON
16	Multi-function input terminal 3	Multi-function input terminal S3 0: Multi-function input terminal S3 is OFF 1: Multi-function input terminal S3 is ON
17	Multi-function input terminal 4	Multi-function input terminal S4 0: Multi-function input terminal S4 is OFF 1: Multi-function input terminal S4 is ON
18	Multi-function input terminal 5	Multi-function input terminal S5 0: Multi-function input terminal S5 is OFF 1: Multi-function input terminal S5 is ON
19	Multi-function input terminal 6	Multi-function input terminal S6 0: Multi-function input terminal S6 is OFF 1: Multi-function input terminal S6 is ON
20	Multi-function input terminal 7	Multi-function input terminal S7 0: Multi-function input terminal S7 is OFF 1: Multi-function input terminal S7 is ON
21	Multi-function input terminal 8 <1>	Multi-function input terminal S8 0: Multi-function input terminal S8 is OFF 1: Multi-function input terminal S8 is ON

<1> GA500 does not have multi-function digital input 8.

■ INVCMD_IO Command

Vender Specific							
Bit 7	Bit 6	Bit 5	Bit 4	Bit 3	Bit 2	Bit 1	Bit 0
Not used							
Vender Specific							
Bit 15	Bit 14	Bit 13	Bit 12	Bit 11	Bit 10	Bit 9	Bit 8
Not used							
Vender Specific							
Bit 23	Bit 22	Bit 21	Bit 20	Bit 19	Bit 18	Bit 17	Bit 16
Not used							
Bit 31	Bit 30	Bit 29	Bit 28	Vender Specific			
Reserved (0)				Bit 27	Bit 26	Bit 25	Bit 24
				Not used			

Table 21 SEL_REF Reference Data Codes

Selection Code	Monitor Name	Contents
0	Nothing Selected	–
1	Torque Compensation	Unit: 0.1%
2	Analog Output Terminal 1 Output	Enabled when H4-01 = 000
3	1000-Series Drives, GA700, GA800, CR700, and CH700: Analog Output Terminal 2 Output GA500: Not used	1000-Series Drives, GA700, GA800, CR700, and CH700: Enabled when H4-04 = 000 GA500: -
4	Terminal Output	–
5	PID Setpoint	Unit: 0.01%
6	Pulse Output	Unit: 1 Hz
7	V/f Gain	–
8	Not used	–
9	Control Selection Setting	Bit 1: PID setpoint enabled

Table 22 SEL_MON Monitor Data Codes

Selection Code	Monitor Name	Contents
0	Nothing Selected	–
1	Motor Speed	Displayed in U1-05 and determined by o1-03.
2	Torque Reference (Monitor)	Displayed in U1-09 (0.1%).
3	1000-Series Drives, GA700, GA800, CR700, and CH700: Speed Detection PG 1 Counter GA500: Not used	–
4	Frequency Reference	Displayed in U1-01 and determined by o1-03.
5	Analog Input Terminal A2	Displayed in U1-14 (0.1%).
6	DC Bus Voltage	Displayed in U1-07 (1 V).
7	Inverter Alarm	–
8	Inverter Warning	–
9	Multi-Function Output Terminal Status	Displayed in U1-11.
A	1000-Series Drives, GA700, GA800, CR700, and CH700: Analog Input Terminal GA500: Not used	1000-Series Drives, GA700, GA800, CR700, and CH700: Displayed in U1-15 (0.1%). GA500: -
B	1000-Series Drives, GA700, GA800, CR700, and CH700: Multi-Function Input Terminal Status S1 to S8 GA500: Multi-Function Input Terminal Status S1 to S7	Displayed in U1-10.
C	Analog Input Terminal	Displayed in U1-13 (0.1%).
D	1000-Series Drives, GA700, GA800, CR700, and CH700: Speed Detection PG2 Counter GA500: Not used	–
E	Monitor Data Set to F6-23	–
F	Monitor Data Set to F6-24	–

■ INV_CTL Response

INV_CTL Response		
Byte	Response	Contents
0	INV_CTL (50H)	Command code
1	RWDT	Watchdog data
2	CMD_STAT	Refer to Command Status (CMD_STAT) on page 31.
3		
4	INVCMD_STAT	Refer to INVCMD_CTRL on page 42.
5		
6		
7		
8	INVCMD_IO	Refer to INVCMD_IO Command on page 43.
9		
10		
11		
12	Output Frequency	Output Frequency (Lower)
13		Output Frequency (Upper)
14		Not used (Set to 0.)
15		Not used (Set to 0.)
16	Output Current	Output current (Lower)
17		Output current (Upper)
18		Not used (Set to 0.)
19		Not used (Set to 0.)
20	SEL_REF1/2	The value set in the command.
21	SEL_MON1/2	The value set in the command.
22	Reserved (0)	Not used (Set to 0.)
23		
24	Monitor data set to SEL_MON1	Monitor data set to SEL_MON1 (Lower)
25		Monitor data set to SEL_MON1 (Upper)
26		Not used (Set to 0.)
27		Not used (Set to 0.)
28	Monitor data set to SEL_MON2	Monitor data set to SEL_MON2 (Upper)
29		Monitor data set to SEL_MON2 (Upper)
30		Not used (Set to 0.)
31		Not used (Set to 0.)

■ INVCMD_STAT

Vender Specific						Bit 1	Bit 0
Bit 7	Bit 6	Bit 5	Bit 4	Bit 3	Bit 2		
oPE Error	Drive Ready	Speed Agree	Zero Servo	Main Power Supply ON	Basblock Released	Reverse Operation	Forward Operation
Vender Specific						Bit 9	Bit 8
Bit 15	Bit 14	Bit 13	Bit 12	Bit 11	Bit 10		
Not used		Zero Servo	Motor 2 Selection	LOCAL/REMOTE	Power Loss Recovery/ Momentary Power Loss Recovery	Fault reset Signal Input	Reserved (0)
Vender Specific							
Bit 23	Bit 22	Bit 21	Bit 20	Bit 19	Bit 18	Bit 17	Bit 16
Not used							
Bit 31	Bit 30	Bit 29	Bit 28	Bit 27	Bit 26	Bit 25	Bit 24
Reserved (0)						SEL_MON2 Status	SEL_MON1 Status

Bit	Name	Description
0	Forward Operation	0: Stop 1: Forward operation in progress
1	Reverse Operation	0: Stop 1: Reverse operation in progress
2	Baseblock Released	0: Baseblock 1: Baseblock released
3	Main Power Supply ON	0: Main power supply OFF 1: Main power supply ON
4	Zero speed	1: Zero Speed
5	Speed Agree	1: Speed agree
6	Drive Ready	1: Drive ready
7	oPE Error	1: oPE error
9	Fault Reset Signal being Input	1: Fault reset signal being input
10	Power Loss Recovery/ Momentary Power Loss Recovery	0: Power loss recovery 1: Momentary power loss recovery
11	LOCAL/REMOTE	0: LOCAL 1: REMOTE
12	Motor 2 Selection	0: Motor 1 1: Motor 2
13	Zero Servo	1: Zero servo
24	SEL_MON1 Status	0: Disabled 1: SEL_MON1 enabled
25	SEL_MON2 Status	0: Disabled 1: SEL_MON2 enabled

■ INVCMD_IO Response

Vender Specific							
Bit 7	Bit 6	Bit 5	Bit 4	Bit 3	Bit 2	Bit 1	Bit 0
Not used							
Vender Specific							
Bit 15	Bit 14	Bit 13	Bit 12	Bit 11	Bit 10	Bit 9	Bit 8
Not used							
Vender Specific							
Bit 23	Bit 22	Bit 21	Bit 20	Bit 19	Bit 18	Bit 17	Bit 16
Not used							
Bit 31	Bit 30	Bit 29	Bit 28	Vender Specific			
Reserved (0)				Bit 27	Bit 26	Bit 25	Bit 24
				Not used			

10 Sub-Commands

Use sub-commands after selecting the 64-byte data transmission (F6-21 = 0).

◆ SUB_CTRL (Sub-Command Control Field)

Table 23 SUB_CTRL

Bit 7	Bit 6	Bit 5	Bit 4	Bit 3	Bit 2	Bit 1	Bit 0
Reserved (0)							
Bit 15	Bit 14	Bit 13	Bit 12	Bit 11	Bit 10	Bit 9	Bit 8
Reserved (0)							
Bit 23	Bit 22	Bit 21	Bit 20	Bit 19	Bit 18	Bit 17	Bit 16
Reserved (0)							

◆ SUB_STAT (Sub-Command Status)

Table 24 SUB_STAT

Bit 7	Bit 6	Bit 5	Bit 4	Bit 3	Bit 2	Bit 1	Bit 0
Not used (Set to 0.)				Reserved (0)	SUBCMDRDY	Not used	
Bit 15	Bit 14	Bit 13	Bit 12	Bit 11	Bit 10	Bit 9	Bit 8
Reserved (0)				SUBCMD_ALM			
Bit 23	Bit 22	Bit 21	Bit 20	Bit 19	Bit 18	Bit 17	Bit 16
Reserved (0)							

Command	Description
SUBCMDRDY	0: Sub-command reception disabled 1: Sub-command reception enabled
SUBCMD_ALM	Notifies the sub-command error state. If a normal sub-command is received after the occurrence of a sub-command error, SUBCMD_ALM is automatically cleared.

Table 25 SUBCMD_ALM

Code	Contents
–	0H Normal
Warning	1H Invalid data
Alarm	8H Unsupported command received
	9H Invalid data
	AH Invalid data
	BH Sub-command combination error
CH	Phase error

■ NOP: 00H (No Operation Command)

The NOP command is used for network control. The current state is returned as a response. The command can be used in all communication phases.

NOP Command		
Byte	Command	Description
32	NOP (00H)	Command code
33	SUB_CTRL	Refer to <i>SUB_CTRL (Sub-Command Control Field)</i> on page 47.
34		
35	Reserved (0)	Not used
36		
37		
·		
·		
63		

10 Sub-Commands

NOP Response		
Byte	Response	Description
32	NOP (00H)	Command code
33	SUB_STAT	Refer to <i>SUB_STAT (Sub-Command Status) on page 47.</i>
34		
35		
36	Reserved (0)	Not used
37		
.		
.		
63		

■ PRM_RD: 01H (Read Parameter Command)

The PRM_RD command specifies the parameter number and the data size to read a parameter. The command can be used in communication phases 2 and 3. Refer to the drive manual for MEMOBUS/Modbus register numbers.

PRM_RD Command		
Byte	Command	Description
32	PRM_RD (01H)	Command code
33	SUB_CTRL	Refer to <i>SUB_CTRL (Sub-Command Control Field) on page 47.</i>
34		
35		
36	NO	MEMOBUS/Modbus register number (Lower)
37		MEMOBUS/Modbus register number (Upper)
38	SIZE	Specify the parameter data size in bytes. 2, 4, 6, and 8 are available.
39	Reserved (0)	Not used
40		
41		
42		
.		
63		

PRM_RD Response		
Byte	Response	Description
32	PRM_RD (01H)	Command code
33	SUB_STAT	Refer to <i>SUB_STAT (Sub-Command Status) on page 47.</i>
34		
35		
36	NO	The value (Lower) set in the command.
37		The value (Upper) set in the command.
38	SIZE	The value set in the command.
39	Reserved (0)	0 is set.
40	PARAMETER	Sets the data read in the byte set in the command. The option stores the data read for PARAMETER from lower byte (LSB) to upper byte (MSB). 0 is stored when the field is not used. 0 is stored in PARAMETER when command error occurs.
41		
42		
.		
.		
63		

■ PRM_WR: 02H (Write Parameter Sub-Command)

The PRM_WR command specifies the parameter number, data size, and parameter data to write a parameter. The command can be used in communication phases 2 and 3. Send the CONFIG command after writing the parameters to make the parameters effective. Refer to the drive manual for details on MEMOBUS/Modbus register numbers.

PRM_RDA Command		
Byte	Command	Description
32	PRM_WR (02H)	Command code
33	SUB_CTRL	Refer to <i>SUB_CTRL (Sub-Command Control Field)</i> on page 47.
34		
35		
36	NO	MEMOBUS/Modbus register number (Lower)
37		MEMOBUS/Modbus register number (Upper)
38	SIZE	Specify the parameter data size in bytes. 2, 4, 6, and 8 are available.
39	Reserved (0)	Not used
40	PARAMETER	Specify the lower byte (LSB) before the upper byte (MSB) in the size set in the SIZE.
41		
42		
.		
.		
63		

PRM_WR Response		
Byte	Response	Description
32	PRM_WR (02H)	Command code
33	SUB_STAT	Refer to <i>SUB_STAT (Sub-Command Status)</i> on page 47.
34		
35		
36	NO	The value (Lower) set in the command.
37		The value (Upper) set in the command.
38	SIZE	The value set in the command.
39	Reserved (0)	0 is set.
40	PARAMETER	The value set in the command. 0 is stored when the field is not used.
41		
42		
.		
.		
63		

In the following statuses, an alarm is detected and the command goes into error.

Error	Response
Register Number Error	“9” is set for SUBCMD_ALM.
Bit Count Error	“9” is set for SUBCMD_ALM.
Data Setting Error	“9” is set for SUBCMD_ALM.
Write Mode Error	“9” is set for SUBCMD_ALM.
Writing Error during Under Voltage	“9” is set for SUBCMD_ALM.
Writing Error during Parameter Processing	“9” is set for SUBCMD_ALM.

■ ALM_RD: 05H (Read Alarm or Warning Command)

The ALM_RD command reads the alarm or warning state. The command can be used in communication phases 2 and 3. The current alarm or warning state is read to ALM_DATA as an alarm or warning code. Refer to the drive manual for details on ALM_DATA.

10 Sub-Commands

ALM_RD Command		
Byte	Command	Description
32	ALM_RD (05H)	Command code
33	SUB_CTRL	Refer to <i>SUB_CTRL (Sub-Command Control Field) on page 47.</i>
34		
35		
36	ALM_RD_MOD	Specify the alarm or warning state. (Lower)
37		Specify the alarm or warning state. (Upper)
38	ALM_INDEX	Specify the alarm index. The command is enable when ALM_RD_MODE is 2. (Lower)
39		Specify the alarm index. The command is enable when ALM_RD_MODE is 2. (Upper)
40	Reserved (0)	Not used
41		
42		
.		
.		
63		

ALM_RD Response		
Byte	Response	Description
32	ALM_RD (05H)	Command code
33	SUB_STAT	Refer to <i>SUB_STAT (Sub-Command Status) on page 47.</i>
34		
35		
36	ALM_RD_MOD	The value set in the command.
37		
38	ALM_INDEX	The value set in the command.
39		
40	ALM_DATA	ALM_DATA specifies an alarm using 2 bytes.
41		
42		
.		
.		
63		

■ INV_I/O: 51H (Inverter I/O Control Command)

The INV_I/O command sets the drive I/O, displays the monitor value, and executes references.

INV_IO Command		
Byte	Command	Description
32	INV_IO (51H)	Command code
33	SUB_CTRL	Refer to <i>SUB_CTRL (Sub-Command Control Field) on page 47.</i>
34		
35		
36	SEL_REF 3/4	Use the SEL REF3/4 command to select the contents of REF3 with bits 0 to 3 and to select the contents of REF4 with bits 4 to 7. Refer to Table 21 for the selection ranges for SEL REF3/4 and SEL MON3/4.
37	SEL_REF 5/6	Use the SEL REF5/6 command to select the contents of REF5 with bits 0 to 3 and to select the contents of REF6 with bits 4 to 7. Refer to Table 21 for the selection ranges for SEL REF5/6 and SEL MON5/6.
38	SEL_MON 3/4	Use the SEL MON3/4 command to select the contents of MON3 with bits 0 to 3 and to select the contents of MON4 with bits 4 to 7. Refer to Table 22 for the selection ranges for SEL REF3/4 and SEL MON3/4.

INV_IO Command		
Byte	Command	Description
39	SEL_MON 5/6	Use the SEL MON5/6 command to select the contents of MON5 with bits 0 to 3 and to select the contents of MON6 with bits 4 to 7. Refer to Table 22 for the selection ranges for SEL REF5/6 and SEL MON5/6.
40	Reference selected with SEL_REF3	Reference selected with SEL_REF3 (Lower)
41		Reference selected with SEL_REF3 (Upper)
42		Not used (Ignored if a value is set.)
43		Not used (Ignored if a value is set.)
44	Reference selected with SEL_REF4	Reference selected with SEL_REF4 (Lower)
45		Reference selected with SEL_REF4 (Upper)
46		Not used (Set to 0.)
47		Not used (Set to 0.)
48	Reference selected with SEL_REF5	Reference selected with SEL_REF5 (Lower)
49		Reference selected with SEL_REF5 (Upper)
50		Not used (Set to 0.)
51		Not used (Set to 0.)
52	Reference selected with SEL_REF6	Reference selected with SEL_REF6 (Lower)
53		Reference selected with SEL_REF6 (Upper)
54		Not used (Set to 0.)
55		Not used (Set to 0.)
56	Reserved (0)	Not used
.		
.		
63		

INV_IO Response		
Byte	Command	Description
32	INV_IO (51H)	Command code
33	SUB_STAT	Refer to SUB_STAT (Sub-Command Status) on page 47.
34		
35		
36	SEL_REF 3/4	The value set in the command.
37	SEL_REF 5/6	The value set in the command.
38	SEL_MON 3/4	The value set in the command.
39	SEL_MON 5/6	The value set in the command.
40	Monitor data set to SEL_MON3	Monitor data set to SEL_MON3 (Lower)
41		Monitor data set to SEL_MON3 (Upper)
42		Not used (Set to 0.)
43		Not used (Set to 0.)
44	Monitor data set to SEL_MON4	Monitor data set to SEL_MON4 (Lower)
45		Monitor data set to SEL_MON4 (Upper)
46		Not used (Set to 0.)
47		Not used (Set to 0.)
48	Monitor data set to SEL_MON5	Monitor data set to SEL_MON5 (Lower)
49		Monitor data set to SEL_MON5 (Upper)
50		Not used (Set to 0.)
51		Not used (Set to 0.)
52	Monitor data set to SEL_MON6	Monitor data set to SEL_MON6 (Lower)
53		Monitor data set to SEL_MON6 (Upper)
54		Not used (Set to 0.)
55		Not used (Set to 0.)
56	Reserved (0)	Not used
.		
.		
63		

11 Troubleshooting

◆ Drive-Side Error Codes

Drive-side error codes appear on the drive keypad. [Table 26](#) lists causes of the errors and possible corrective actions. Refer to the drive Technical Manual for additional error codes that may appear on the drive keypad.

■ Faults

bUS (Option Communication Error), E5 (MECHATROLINK Watchdog Timer Error), and EF0 (Option Card External Fault from the option) can appear as an alarm or as a fault. When a fault occurs, the keypad ALM LED remains lit. When an alarm occurs, the ALM LED flashes.

If communication stops while the drive is running, use the following questions as a guide to help remedy the fault:

- Is the option properly installed?
- Is the communication line properly connected to the option? Is it loose?
- Is the controller program working? Has the controller/PLC CPU stopped?
- Did a momentary power loss interrupt communications?

Table 26 Fault Display and Possible Solutions

Keypad Display		Minor Fault Name
bUS	bUS	Option Communication Error
		<ul style="list-style-type: none"> • After establishing initial communication, the connection was lost • Only detected when the run command or frequency reference is assigned to the option (b1-01 = 3 or b1-02 = 3)
Cause		Possible Solution
No signal was received from the PLC.		<ul style="list-style-type: none"> • Check for faulty wiring. • Correct any wiring problems.
Faulty communications wiring		
An existing short circuit or communications disconnection		Check disconnected cables and short circuits and repair as needed
A data error occurred due to electric interference		<ul style="list-style-type: none"> • Counteract noise in the control circuit, main circuit, and ground wiring. • If a magnetic contactor is identified as a source of noise, install a surge absorber to the contactor coil. • Use only recommended cables or other shielded line. Ground the shield on the controller side or the drive input power side. • Separate all communication wiring from drive power lines. Install an EMC noise filter to the drive power supply input. • Counteract noise in the master controller (PLC).
The option is not properly connected to the drive		Reinstall the option
Option is damaged		If there are no problems with the wiring and the error continues to occur, replace the option.
Connection Time-out		<ul style="list-style-type: none"> • The option Requested Packet Interval (RPI) timer timed out • Make sure that RPI time is set properly
Duplicate Station Address		Check if the option shares Station Address with at least one other node. Check the setting values of F6-20 (MECHATROLINK Station Address).
Keypad Display		Minor Fault Name
E5	E5	MECHATROLINK Watchdog Timer Error
		The watchdog has timed out.
Cause		Possible Solution
Data has not been received from the PLC, triggering the watchdog timer.		Check the MECHATROLINK cable connection. Check for wiring and how to counteract noise according to the following manuals by MECHATROLINK Members Association. MECHATROLINK-III Installation Guide, MMATDEP018A
Keypad Display		Minor Fault Name
EF0	EF0	Option Card External Fault
		The alarm function for an external device has been triggered.
Cause		Possible Solution
An external fault was received from the PLC.		<ol style="list-style-type: none"> 1. Remove the cause of the external fault 2. Reset the external fault input from the PLC
Problem with the PLC program		Check the PLC program.
PLC is in the Idle Mode.		<ol style="list-style-type: none"> 1. Set the PLC to the Run Mode. 2. Set the parameter F6-54 = 0 (Enabled) to ignore errors while the PLC is in the Idle Mode.

Keypad Display		Minor Fault Name
oFA00	oFA00	Option Card Connection Error (CN5-A) Option is not properly connected.
Cause		Possible Solution
The option card installed into port CN5-A is incompatible with the drive.		Connect the option to the correct option port. Note: PG option cards are supported by option ports CN5-B and CN5-C only.
Keypad Display		Minor Fault Name
oFA01	oFA01	Option Card Fault (CN5-A) Option is not properly connected.
Cause		Possible Solution
The option connected to option port CN5-A was changed during run.		De-energize the drive and plug the option into the drive according to Installation Procedure on page 12 .
Keypad Display		Fault Name
oFA03, oFA04	oFA03, oFA04	Option Card Error (CN5-A) Option Card Error (CN5-A)
Cause		Possible Solution
A fault occurred in the option.		1. De-energize the drive. 2. Make sure that the option is correctly connected to the connector. 3. If the problem continues, replace the option.
Keypad Display		Minor Fault Name
oFA30 to oFA43	oFA30 to oFA43	Option Card Connection Error (CN5-A) Communication ID error.
Cause		Possible Solution
The option card connection to port CN5-A is faulty.		1. Turn off the power. 2. Check if the option is properly plugged into the option port. 3. Replace the option if the fault continues to occur.
Keypad Display		Minor Fault Name
oFb00	oFb00	Option Fault (CN5-B) Non-compatible option is connected.
Cause		Possible Solution
The option card installed into port CN5-A is incompatible with the drive.		Connect the option to the correct option port. Note: Use connector CN5-B when connecting DO-A3, AO-A3, or two PG options. Use connector CN5-C when connecting only one PG option.
Keypad Display		Minor Fault Name
oFb02	oFb02	Option Fault (CN5-B) Two identical options are connected at the same time.
Cause		Possible Solution
An option of the same type is already installed in option port CN5-A, CN5-B, or CN5-C.		Connect the option to the correct option port.
Keypad Display		Minor Fault Name
oFC00	oFC00	Option Fault (CN5-C) Non-compatible option is connected.
Cause		Possible Solution
The option card installed into port CN5-C is incompatible with the drive.		Connect the option to the correct option port. Note: AI-A3, DI-A3, and communication options are not supported by option port CN5-C.
Keypad Display		Minor Fault Name
oFC02	oFC02	Option Fault Option Flash write mode.
Cause		Possible Solution
An option of the same type is already installed in option port CN5-A, CN5-B, or CN5-C.		Connect the option to the correct option port.

■ Minor Faults and Alarms

Keypad Display		Minor Fault Name	
CALL	CALL	Serial communication transmission error	
		Communication is not established.	
Cause		Possible Solution	Minor Fault (H2-□□ = 10)
Communication wiring is faulty.		<ul style="list-style-type: none"> Check for wiring errors. Correct the wiring. 	YES
An existing short circuit or communications disconnection		Check disconnected cables and short circuits and repair as needed.	
Programming error on the master side.		Check communications at start-up and correct programming errors.	
Communication circuitry is damaged.		<ul style="list-style-type: none"> Perform a self-diagnostics check If the problem continues, replace either the control board or the entire drive. For instructions on replacing the control board, contact Yaskawa or a Yaskawa representative. 	
Termination resistor of the MEMOBUS/Modbus communications is not enabled.		Set DIP switch S2 to the ON position to enable the termination resistor on a drive located at the end of a network line.	
Keypad Display		Minor Fault Name	
CYC	CYC	MECHATROLINK Communications Cycle Setting Error	
		Communications cycle setting error was detected.	
Cause		Possible Solution	Minor Fault (H2-□□ = 10)
The upper controller is using a communication cycle beyond the allowable setting range for the MECHATROLINK option.		Set the communication cycle for the upper controller within the allowable setting range for the MECHATROLINK option.	YES
Keypad Display		Minor Fault Name	
CyPo	CyPo	Cycle Power to Active Parameters	
		Comm. Option Parameter Not Upgraded	
Cause		Possible Solution	Minor Fault (H2-□□ = 10)
Although F6-15 = 1 [Comm. Option Parameters Reload = Reload Now], the drive did not update the communication option parameters.		Re-energize the drive to update the communication option parameters. Note: If the option software version is not compatible or if you install an incorrect option to the drive, it will trigger an alarm.	YES

◆ Option Compatibility

Users may connect up to 3 options simultaneously depending on the type of option. Refer to [Table 27](#) for details.

Note: You can only connect one option to the GA500. Connect the option card to the CN5 connector.

Table 27 Option Compatibility

Option Card	Connector	Number of Cards Possible
PG-B3, PG-X3	CN5-B, C	2 <1>
PG-RT3 <2> <3>, PG-F3 <2> <3>	CN5-C	1
DO-A3, AO-A3	CN5-A, B, C	1
SI-C3, SI-N3, SI-P3, SI-S3, SI-T3, SI-ET3, SI-ES3, SI-B3, SI-M3, SI-W3 <3>, SI-EM3 <3>, SI-EN3 <3>, SI-EP3, AI-A3 <4>, DI-A3 <4>	CN5-A	1

<1> When connecting two PG option cards, use both CN5-B and CN5-C. When connecting only one PG option card, use the CN5-C connector.

<2> Not available for the application with Motor 2 Selection.

<3> Not available with 1000-Series drive models with a capacities between 450 and 630 kW.

<4> When you use the input status of AI-A3 and DI-A3 as a monitor, you can connect AI-A3 and DI-A3 to CN5-A, CN5-B, or CN5-C.

12 European Standards



Figure 20 CE Mark

The CE mark indicates compliance with European safety and environmental regulations. It is required for engaging in business and commerce in Europe.

European standards include the Machinery Directive for machine manufacturers, the Low Voltage Directive for electronics manufacturers, and the EMC guidelines for controlling noise.

This option displays the CE mark based on the EMC guidelines.

EMC Guidelines: 2014/30/EU

Drives used in combination with this option and devices used in combination with the drive must also be CE certified and display the CE mark. When using drives displaying the CE mark in combination with other devices, it is ultimately the responsibility of the user to ensure compliance with CE standards. Verify that conditions meet European standards after setting up the device.

◆ EMC Guidelines Compliance

This option is tested according to European standards EN 61800-3:2004/A1:2012 and complies with EMC guidelines. The CE marking is declared based on the harmonized standards.

■ EMC Guidelines Installation Conditions

Verify the following installation conditions to ensure that other devices and machinery used in combination with this option and drives also comply with EMC guidelines:

1. Use dedicated shield cable for the option and external device (encoder, I/O device, master), or run the wiring through a metal conduit.
2. Keep wiring as short as possible and ground the largest possible surface area of the shield to the metal panel according to [Figure 22](#).

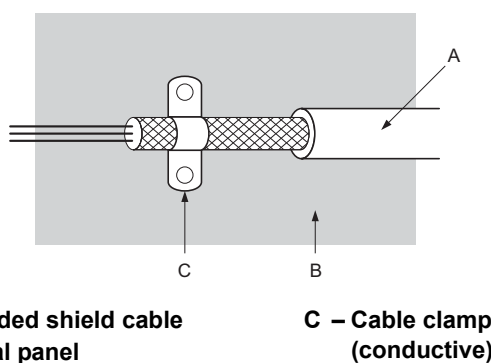

Figure 21 Ground Area

■ Option Installation for CE Compliance: Models PG-□□, DI-□□, DO-□□, AI-□□, AO-□□, SI-□□

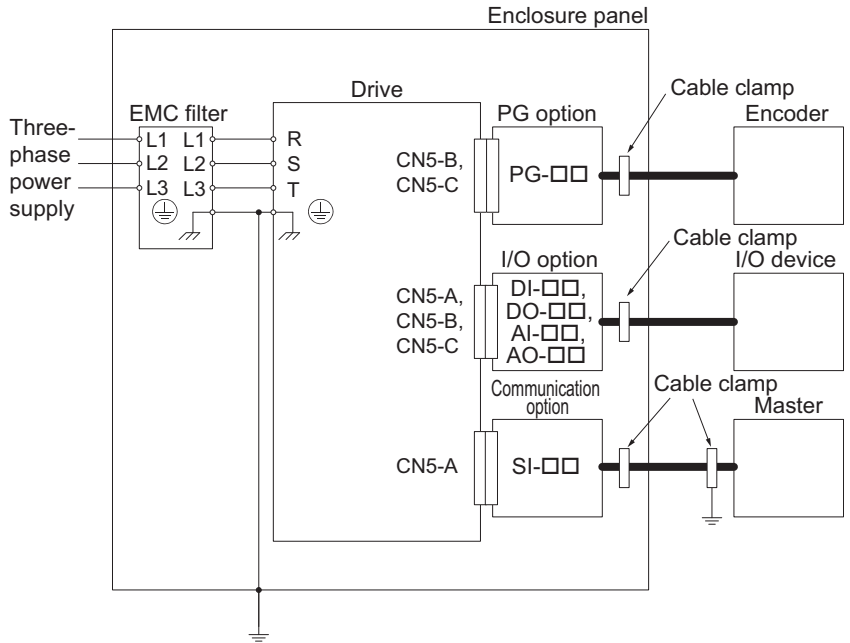

Figure 22 Option Installation for CE Compliance (PG-□□, DI-□□, DO-□□, AI-□□, AO-□□, SI-□□)

■ Option Installation for CE Compliance with GA500

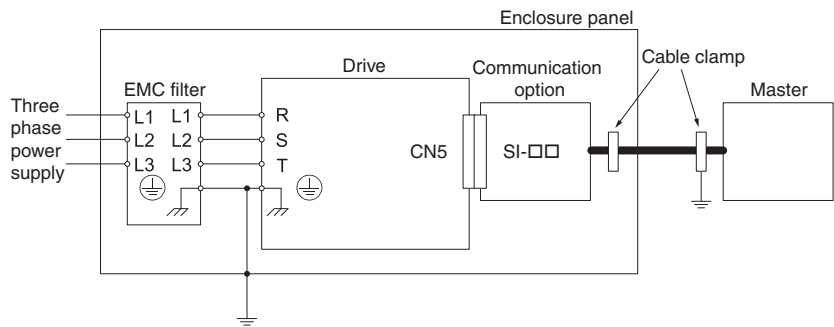

Figure 23 Option Installation for CE Compliance with GA500

13 Specifications

Table 28 Option Specifications

Item	Specification
Model	SI-ET3
Access mode	Start-stop synchronization, master/slave method
Communication speed	100 Mbps
Minimum transmission cycle	250 μ s
Maximum transmission cycle	8 ms
Transmission cycle granularity	03H
Minimum wiring distance between stations	0.2 m (7.9 in)
Maximum wiring distance between stations	100 m (328 ft)
Data length	32-byte data transmission or 64-byte data transmission
Event driven communication	Valid
Profile	Compliant with standard inverter profile
Maximum number of stations	62 <1>
Ambient temperature	-10°C to +50°C (14°F to 122°F)
Humidity	95% RH or lower with no condensation
Storage temperature	-20°C to +60°C (-4°F to 140°F) allowed for short-term transport of the product
Area of use	Indoors and free from: <ul style="list-style-type: none"> • Oil mist, corrosive gas, flammable gas, and dust • Radioactive materials or flammable materials, including wood • Harmful gas or fluids • Salt • Direct sunlight • Falling foreign objects
Altitude	1000 m (3280 ft) or lower

<1> The maximum number of connectable stations changes depending on the types and settings of the host controller, baud rate, and communications cycle. Refer to the host controller manual for details.

14 Disposal

◆ Disposal Instructions

Correctly dispose of this product and packing material as specified by applicable regional, local, and municipal laws and regulations.

◆ WEEE Directive



Figure 24 WEEE Mark

The wheeled bin symbol on this product, its manual, or its packaging identifies that you must recycle it at the end of its product life.

You must discard the product at an applicable collection point for electrical and electronic equipment (EEE).

Do not discard the product with usual waste.

◆ Revision History

Revision dates and manual numbers appear on the bottom of the back cover.

MANUAL NO. SIEP C730600 88B <1>

Published in Japan October 2016

Revision number

Date of publication

Date of Publication	Revision Number	Section	Revised Content
March 2019	<4>	All	Addition: Applicable product series Revision: Reviewed and corrected entire documentation.
		Chapter 14	Addition: Disposal
January 2019	<3>	All	Addition: Applicable product series Revision: Reviewed and corrected entire documentation.
		Back cover	Revision: Address
October 2017	<2>	All	Addition: Applicable product series Revision: Reviewed and corrected entire documentation.
		Back cover	Revision: Address
October 2016	<1>	All	Revision: Applicable product series Revision: Reviewed and corrected entire documentation.
		Back cover	Revision: Address
June 2016	–	–	First edition

YASKAWA AC Drive Option

MECHATROLINK-III

Technical Manual

DRIVE CENTER (INVERTER PLANT)

2-13-1, Nishimiyaichi, Yukuhashi, Fukuoka, 824-8511, Japan
Phone: +81-930-25-2548 Fax: +81-930-25-3431
<http://www.yaskawa.co.jp>

YASKAWA ELECTRIC CORPORATION

New Pier Takeshiba South Tower, 1-16-1, Kaigan, Minatoku, Tokyo, 105-6891, Japan
Phone: +81-3-5402-4502 Fax: +81-3-5402-4580
<http://www.yaskawa.co.jp>

YASKAWA AMERICA, INC.

2121, Norman Drive South, Waukegan, IL 60085, U.S.A.
Phone: +1-800-YASKAWA (927-5292) or +1-847-887-7000 Fax: +1-847-887-7310
<http://www.yaskawa.com>

YASKAWA ELÉTRICO DO BRASIL LTDA.

777, Avenida Piraporinha, Diadema, São Paulo, 09950-000, Brasil
Phone: +55-11-3585-1100 Fax: +55-11-3585-1187
<http://www.yaskawa.com.br>

YASKAWA EUROPE GmbH

Hauptstraße 185, 65760 Eschborn, Germany
Phone: +49-6196-569-300 Fax: +49-6196-569-398
<http://www.yaskawa.eu.com> E-mail: info@yaskawa.eu.com

YASKAWA ELECTRIC KOREA CORPORATION

35F, Three IFC, 10 Gukjegeumyung-ro, Yeongdeungpo-gu, Seoul, 07326, Korea
Phone: +82-2-784-7844 Fax: +82-2-784-8495
<http://www.yaskawa.co.kr>

YASKAWA ASIA PACIFIC PTE. LTD.

30A, Kallang Place, #06-01, 339213, Singapore
Phone: +65-6282-3003 Fax: +65-6289-3003
<http://www.yaskawa.com.sg>

YASKAWA ELECTRIC (THAILAND) CO., LTD.

59, 1st-5th Floor, Flourish Building, Soi Ratchadapisek 18, Ratchadapisek Road, Huaykwang, Bangkok, 10310, Thailand
Phone: +66-2-017-0099 Fax: +66-2-017-0799
<http://www.yaskawa.co.th>

YASKAWA ELECTRIC (CHINA) CO., LTD.

22F, Link Square 1, No.222, Hubin Road, Shanghai, 200021, China
Phone: +86-21-5385-2200 Fax: +86-21-5385-3299
<http://www.yaskawa.com.cn>

YASKAWA ELECTRIC (CHINA) CO., LTD. BEIJING OFFICE

Room 1011, Tower W3 Oriental Plaza, No. 1, East Chang An Ave.,
Dong Cheng District, Beijing, 100738, China
Phone: +86-10-8518-4086 Fax: +86-10-8518-4082

YASKAWA ELECTRIC TAIWAN CORPORATION

12F, No. 207, Sec. 3, Beishin Rd., Shindian Dist., New Taipei City 23143, Taiwan
Phone: +886-2-8913-1333 Fax: +886-2-8913-1513 or +886-2-8913-1519
<http://www.yaskawa.com.tw>

YASKAWA INDIA PRIVATE LIMITED

#17/A, Electronics City, Hosur Road, Bangalore, 560 100 (Karnataka), India
Phone: +91-80-4244-1900 Fax: +91-80-4244-1901
<http://www.yaskawaindia.in>

YASKAWA

YASKAWA ELECTRIC CORPORATION

In the event that the end user of this product is to be the military and said product is to be employed in any weapons systems or the manufacture thereof, the export will fall under the relevant regulations as stipulated in the Foreign Exchange and Foreign Trade Regulations. Therefore, be sure to follow all procedures and submit all relevant documentation according to any and all rules, regulations and laws that may apply. Specifications are subject to change without notice for ongoing product modifications and improvements.

© 2016 YASKAWA ELECTRIC CORPORATION

MANUAL NO. SIEP C730600 88E <4>-0

Published in Japan March 2019
18-11-20